

## Foreword

---

**Congratulations on choosing a SUBARU vehicle. This Owner's Manual has all the information necessary to keep your SUBARU in excellent condition and to properly maintain the emission control system for minimizing emission pollutants. We urge you to read this manual carefully so that you may understand your vehicle and its operation. For information not found in this Owner's Manual, such as details concerning repairs or adjustments, please contact the SUBARU dealer from whom you purchased your SUBARU or the nearest SUBARU dealer.**

**The information, specifications and illustrations found in this manual are those in effect at the time of printing. SUBARU CORPORATION reserves the right to change specifications and designs at any time without prior notice and without incurring any obligation to make the same or similar changes on vehicles previously sold. This Owner's Manual applies to all models and covers all equipment, including factory installed options. Some explanations, therefore may be for equipment not installed in your vehicle.**

**Please leave this manual in the vehicle at the time of resale. The next owner will need the information found herein.**

**SUBARU CORPORATION, TOKYO, JAPAN**

"SUBARU" and the six-star cluster design are registered trademarks of SUBARU CORPORATION.

© Copyright 2021 SUBARU CORPORATION



This manual describes the following vehicle types.

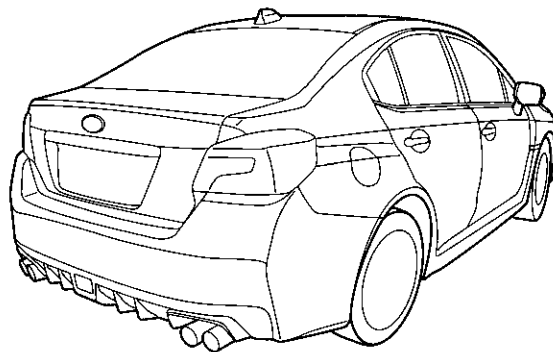
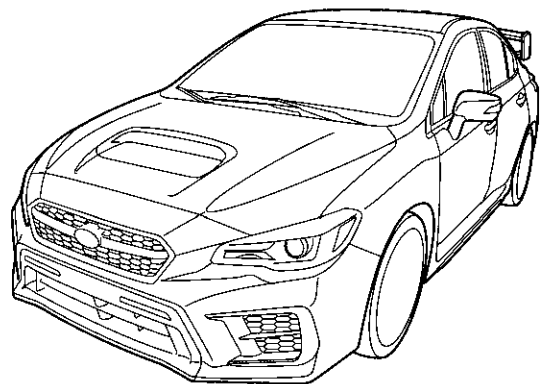

001778





## Warranties

---

### ■ Warranties for U.S.A.

All SUBARU vehicles distributed by Subaru of America, Inc. and sold at retail by an authorized SUBARU dealer in the United States come with the following warranties:

- **SUBARU Limited Warranty**
- **Emission Control Systems Warranty**
- **Emissions Performance Warranty**

All warranty information, including details of coverage and exclusions, is in the "Warranty and Maintenance Booklet". Read these warranties carefully.

### ■ Warranties for Canada

All SUBARU vehicles distributed by Subaru Canada, Inc. and sold at retail by an authorized SUBARU dealer in Canada come with the following warranties:

- **SUBARU Limited Warranty**
- **Anti-Corrosion Warranty**
- **Emission Control Warranty**

All warranty information, including details of coverage and exclusions, is in the "Warranty and Service Booklet". Read these warranties carefully.

### ■ Warranties except for U.S.A. and Canada

All warranty information, including details of coverage and exclusions, is in the "Warranty and Maintenance Booklet". Read these warranties carefully.

## How to use this Owner's Manual

---

### ■ Using your Owner's Manual

Before you operate your vehicle, carefully read this manual. To protect yourself and extend the service life of your vehicle, follow the instructions in this manual. Failure to observe these instructions may result in serious injury and damage to your vehicle.

This manual is composed of fourteen chapters. Each chapter begins with a brief table of contents, so you can usually tell at a glance if that chapter contains the information you want.

#### **Chapter 1: Seat, seatbelt and SRS airbags**

This chapter informs you how to use the seat and seatbelt and contains precautions for the SRS airbags.

#### **Chapter 2: Keys and doors**

This chapter informs you how to operate the keys, locks and windows.

#### **Chapter 3: Instruments and controls**

This chapter informs you about the operation of instrument panel indicators and how to use the instruments and other switches.

**Chapter 4: Climate control**

This chapter informs you how to operate the climate control.

**Chapter 5: Audio**

This chapter informs you about your audio system.

**Chapter 6: Interior equipment**

This chapter informs you how to operate interior equipment.

**Chapter 7: Starting and operating**

This chapter informs you how to start and operate your SUBARU.

**Chapter 8: Driving tips**

This chapter informs you how to drive your SUBARU in various conditions and explains some safety tips on driving.

**Chapter 9: In case of emergency**

This chapter informs you what to do if you have a problem, such as a flat tire or engine overheating.

**Chapter 10: Appearance care**

This chapter informs you how to keep your SUBARU looking good.

**Chapter 11: Maintenance and service**

This chapter informs you when you need to take your SUBARU to the dealer for scheduled maintenance and informs you how to keep your SUBARU running properly.

**Chapter 12: Specifications**

This chapter informs you about dimensions and capacities of your SUBARU.

**Chapter 13: Consumer information and Reporting safety defects**

This chapter informs you about Uniform tire quality grading standards and Reporting safety defects.

**Chapter 14: Index**

This is an alphabetical listing of all that's in this manual. You can use it to quickly find something you want to read.

**For models with the EyeSight system:**

For details about the EyeSight system, refer to the Owner's Manual supplement for the EyeSight system.

Depending on specifications, the vehicle shown in the illustrations may differ from your vehicle in terms of equipment.

**■ Safety warnings**

You will find a number of WARNINGS, CAUTIONS and NOTES in this manual.

These safety warnings alert you to potential hazards that could result in injury to you or others.

Please read these safety warnings as well as all other portions of this manual carefully in order to gain a better understanding of how to use your SUBARU vehicle safely.

**WARNING**

**A WARNING indicates a situation in which serious injury or death could result if the warning is ignored.**

**CAUTION**

**A CAUTION indicates a situation in which injury or damage to your vehicle, or both, could result if the caution is ignored.**

**NOTE**

**A NOTE gives information or suggestions how to make better use of your vehicle.**

## ■ Safety symbol

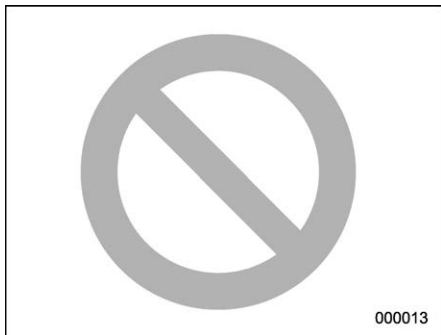

You will find a circle with a slash through it in this manual. This symbol means “Do not”, “Do not do this”, or “Do not let this happen”, depending upon the context.

## ■ Abbreviation list

You may find several abbreviations in this manual. The meanings of the abbreviations are shown in the following list.



Abbreviation	Meaning
A/C	Air conditioner
ABS	Anti-lock brake system
AKI	Anti knock index
ALR	Automatic locking retractor
ALR/ELR	Automatic locking retractor/ Emergency locking retractor
AVH	Auto Vehicle Hold
AWD	All-wheel drive
BSD/RCTA	Blind Spot Detection/Rear Cross Traffic Alert
CVT	Continuously variable trans- mission
C.DIFF/ DCCD	Driver's control center differ- ential
DRL	Daytime running light
EBD	Electronic brake force distri- bution
ELR	Emergency locking retractor
GAW	Gross axle weight
GAWR	Gross axle weight rating
GPS	Global positioning system
GVW	Gross vehicle weight

Abbreviation	Meaning
GVWR	Gross vehicle weight rating
INT	Intermittent
LATCH	Lower anchors and tethers for children
LED	Light emitting diode
LSD	Limited slip differential
MIL	Malfunction indicator light
MMT	Methylcyclopentadienyl man- ganese tricarbonyl
MT	Manual transmission
OBD	On-board diagnostics
RAB	Reverse Automatic Braking
RON	Research octane number
SI-DRIVE	SUBARU Intelligent Drive
SRH	Steering Responsive Head- light
SRS	Supplemental restraint sys- tem
TIN	Tire identification number
TPMS	Tire pressure monitoring sys- tem

## Vehicle symbols

These are some of the symbols you may see on your vehicle.

For warning and indicator lights, refer to “Warning and indicator lights” 23.

Mark	Name
	WARNING
	CAUTION

## Safety precautions when driving

### ■ Seatbelt and SRS airbag

#### WARNING

- All persons in the vehicle must fasten their seatbelts **BEFORE** the vehicle starts to move. Otherwise, the possibility of serious injury becomes greater in the event of a sudden stop or accident.
- To obtain maximum protection in the event of an accident, the driver and all passengers must always wear seatbelts when in the vehicle. The SRS (Supplemental Restraint System) airbag does not do away with the need to fasten seatbelts. In combination with the seatbelts, it offers the best combined protection in case of a serious accident.

Not wearing a seatbelt increases the chance of severe injury or death in a crash even when the vehicle has the SRS airbag.

- The SRS airbags deploy with considerable speed and force. Occupants who are out of proper position when the SRS airbag deploys could suffer very serious injuries. Because the SRS airbag needs enough space for deployment, the driver should always sit upright and well back in the seat as far from the steering wheel as practical while still maintaining full vehicle control and the front passenger should move the seat as far back as possible and sit upright and well back in the seat.

For instructions and precautions, carefully read the following sections.

- For the seatbelt system, refer to “Seatbelts” 1-12.
- For the SRS airbag system, refer to “SRS airbag (Supplemental Restraint System airbag)” 1-35.

## ■ Child safety



### WARNING

- Never hold a child on your lap or in your arms while the vehicle is moving. The passenger cannot protect the child from injury in a collision, because the child will be caught between the passenger and objects inside the vehicle.
- While riding in the vehicle, infants and small children should always be seated in the REAR seat in an infant or child restraint system which is appropriate for the child's age, height and weight. If a child is too big for a child restraint system, the child should sit in the REAR seat and be restrained using the seatbelts. According to accident statistics, children are safer when properly restrained in the rear seating positions than in the front seating positions. Never allow a child to stand up or kneel on the seat.
- Place children in the REAR seat properly restrained at all times in a child restraint device or in a seatbelt. The SRS airbag deploys

with considerable speed and force and can injure or even kill children, especially if they are not restrained or improperly restrained. Because children are lighter and weaker than adults, their risk of being injured from deployment is greater.

- NEVER INSTALL A CHILD SEAT IN THE FRONT SEAT. DOING SO RISKS SERIOUS INJURY OR DEATH TO THE CHILD BY PLACING THE CHILD'S HEAD TOO CLOSE TO THE SRS AIRBAG.
- Always turn the child safety locks to the "LOCK" position when children sit in the rear seat. Serious injury could result if a child accidentally opens the door and falls out. Refer to "Child safety locks" ¶2-31.
- Always lock the passenger's windows using the lock switch when children are riding in the vehicle. Failure to follow this procedure could result in injury to a child operating the power window. Refer to "Windows" ¶2-31.
- Never leave unattended children, adults or animals in the vehicle. They could accidentally injure

themselves or others through inadvertent operation of the vehicle. Also, on hot or sunny days, temperature in a closed vehicle could quickly become high enough to cause severe or possibly fatal injuries to them.

- Help prevent children, adults or animals from locking themselves in the trunk. On hot or sunny days, the temperature in the trunk could quickly become high enough to cause death or serious heat-related injuries including brain damage to anyone locked inside, particularly for small children.
- When leaving the vehicle, close all windows and lock all doors. Also make certain that the trunk is closed.

For instructions and precautions, carefully read the following sections.

- For the seatbelt system, refer to "Seatbelts" ¶1-12.
- For the child restraint system, refer to "Child restraint systems" ¶1-21.
- For the SRS airbag system, refer to "SRS airbag (Supplemental Restraint System airbag)" ¶1-35.

## ■ Engine exhaust gas (carbon monoxide)

### WARNING

- Never inhale engine exhaust gas. Engine exhaust gas contains carbon monoxide, a colorless and odorless gas which is dangerous, or even lethal, if inhaled.
- Always properly maintain the engine exhaust system to prevent engine exhaust gas from entering the vehicle.
- Never run the engine in a closed space, such as a garage, except for the brief time needed to drive the vehicle in or out of it.
- Avoid remaining in a parked vehicle for a lengthy time while the engine is running. If that is unavoidable, then use the ventilation fan to force fresh air into the vehicle.
- Always keep the front ventilator inlet grille free from snow, leaves or other obstructions to ensure that the ventilation system always works properly.
- If at any time you suspect that exhaust fumes are entering the

vehicle, have the problem checked and corrected as soon as possible. If you must drive under these conditions, drive only with all windows fully open.

- Keep the trunk lid closed while driving to prevent exhaust gas from entering the vehicle.

## ■ Drinking and driving

### WARNING

Drinking and then driving is very dangerous. Alcohol in the bloodstream delays your reaction time and impairs your perception, judgment and attentiveness. If you drive after drinking – even if you drink just a little – it will increase the risk of being involved in a serious or fatal accident, injuring or killing yourself, your passengers and others. In addition, if you are injured in the accident, alcohol may increase the severity of that injury.

**Please don't drink and drive.**

Drunken driving is one of the most frequent causes of accidents. Since alcohol affects all people differently, you may have con-

sumed too much alcohol to drive safely even if the level of alcohol in your blood is below the legal limit. The safest thing you can do is never drink and drive. However if you have no choice but to drive, stop drinking and sober up completely before getting behind the wheel.

## ■ Drugs and driving

### WARNING

There are some drugs (over the counter and prescription) that can delay your reaction time and impair your perception, judgment and attentiveness. If you drive after taking them, it may increase your, your passengers' and other persons' risk of being involved in a serious or fatal accident.

If you are taking any drugs, check with your doctor or pharmacist or read the literature that accompanies the medication to determine if the drug you are taking can impair your driving ability. Do not drive after taking any medications that can make you drowsy or otherwise affect your ability to safely operate a motor vehicle. If you have a medical condition that requires you to take drugs, please consult with your doctor.

Never drive if you are under the influence of any illicit mind-altering drugs. For your own health and well-being, we urge you not to take illegal drugs in the first place and to seek treatment if you are addicted to those drugs.

## ■ Driving when tired or sleepy

### WARNING

When you are tired or sleepy, your reaction time will be delayed and your perception, judgment and attentiveness will be impaired. If you drive when tired or sleepy, your, your passengers' and other persons' chances of being involved in a serious accident may increase.

Please do not continue to drive but instead find a safe place to rest if you are tired or sleepy. On long trips, you should make periodic rest stops to refresh yourself before continuing on your journey. When possible, you should share the driving with others.

## ■ Modification of your vehicle

### WARNING

Do not remove the SUBARU genuine navigation and/or audio system. If the SUBARU genuine navigation and/or audio system is removed, the rear view camera image and help lines (distance marker, dynamic guidelines and vehicle width lines) will no longer be displayed.

### CAUTION

Your vehicle should not be modified other than with genuine SUBARU parts and accessories. Other types of modifications could affect its performance, safety or durability, and may even violate governmental regulations. In addition, damage or performance problems resulting from modification may not be covered under warranties.

## NOTE

This vehicle is equipped with a function that will record certain vehicle data in the event the vehicle is operated or maintained in a manner that exceeds or

varies from routine normal use. That data may be used as a means of determining whether or not a vehicle condition is eligible for repair under warranty.

## ■ Car phone/cell phone and driving

### CAUTION

Do not use a car phone/cell phone while driving; it may distract your attention from driving and can lead to an accident. If you use a car phone/cell phone, pull off the road and park in a safe place before using your phone. In some States/Provinces, only hands-free phones may legally be used while driving.

## ■ Driving vehicles equipped with navigation system

### WARNING

Do not allow the monitor to distract your attention from driving. Also, do not operate the controls of the navigation system while driving. The loss of attention to driving could

**lead to an accident. If you wish to operate the controls of the navigation system, first take the vehicle off the road and stop it in a safe place.**

## ■ Driving with pets

Unrestrained pets can interfere with your driving and distract your attention from driving. In a collision or sudden stop, unrestrained pets or cages can be thrown around inside the vehicle and hurt you or your passengers. Besides, the pets can be hurt under these situations. It is also for their own safety that pets should be properly restrained in your vehicle. Restraining a pet with a special traveling harness which can be secured to the rear seat with a seatbelt or use a pet carrier which can be secured to the rear seat by routing a seatbelt through the carrier's handle. Never restrain pets or pet carriers in the front passenger's seat. For further information, consult your veterinarian, local animal protection society or pet shop.

## ■ Tire pressures

Check and, if necessary, adjust the pressure of each tire and the spare (if equipped) at least once a month and before any long journey.

Check the tire pressure when the tires are cold. Use a pressure gauge to adjust the tire pressures to the values shown on the tire inflation pressure label. For detailed information, refer to "Tires and wheels" ☞ 11-29.



### WARNING

**Driving at high speeds with excessively low tire pressures can cause the tires to deform severely and to rapidly become hot. A sharp increase in temperature could cause tread separation, and destruction of the tires. The resulting loss of vehicle control could lead to an accident.**

## ■ Attaching accessories



### WARNING

- **Do not attach any accessories, labels or stickers (other than properly placed inspection stickers) to the windshield. Such items may obstruct your view.**
- **If it is necessary to attach an**

**accessory (such as an electronic toll collection (ETC) device or security pass) to the windshield, consult your SUBARU dealer for details on the proper location.**



## General information

### ■ California Perchlorate Advisory

Certain vehicle components such as air-bag modules, seatbelt pretensioners and keyless entry transmitter batteries may contain perchlorate material. Special handling may apply for service or vehicle end of life disposal. See [www.dtsc.ca.gov/hazardouswaste/perchlorate](http://www.dtsc.ca.gov/hazardouswaste/perchlorate).

### ■ Noise from under the vehicle NOTE

**You may hear a noise from under the vehicle approximately 5 to 10 hours after the engine is turned off. However, this does not indicate a malfunction. This noise is caused by the operation of the fuel evaporation leakage checking system and the operation is normal. The noise will stop after approximately 15 minutes.**

### ■ Event data recorder

This vehicle is equipped with an event data recorder (EDR). The main purpose of an EDR is to record, in certain crash or near crash-like situations, such as an air bag deployment or hitting a road obstacle, data that will assist in understanding how a vehicle's systems performed. The EDR is designed to record data related to vehicle dynamics and safety systems for a short period of time, typically 30 seconds or less. The EDR in this vehicle is designed to record such data as:

- How various systems in your vehicle were operating;
- Whether or not the driver and passenger safety belts were buckled/fastened;
- How far (if at all) the driver was depressing the accelerator and/or brake pedal; and,
- How fast the vehicle was traveling.

These data can help provide a better understanding of the circumstances in which crashes and injuries occur. NOTE: EDR data are recorded by your vehicle only if a non-trivial crash situation occurs; no data are recorded by the EDR under normal driving conditions and no personal data (e.g., name, gender, age, and crash location) are recorded. However, other parties, such as law enforcement, could

combine the EDR data with the type of personally identifying data routinely acquired during a crash investigation.

To read data recorded by an EDR, special equipment is required, and access to the vehicle or the EDR is needed. In addition to the vehicle manufacturer, other parties, such as law enforcement, that have the special equipment, can read the information if they have access to the vehicle or the EDR.

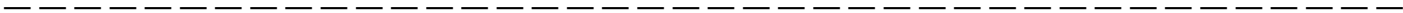
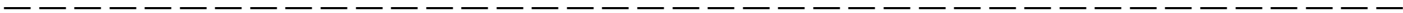
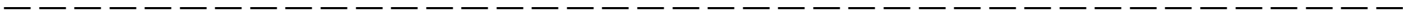
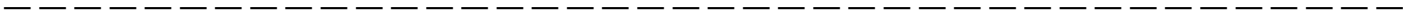
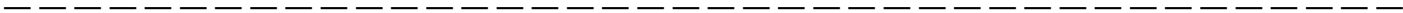
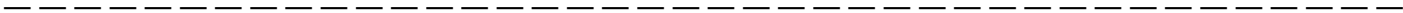
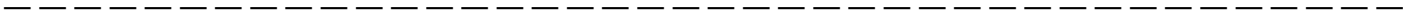
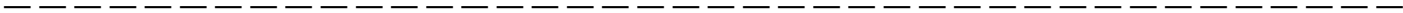
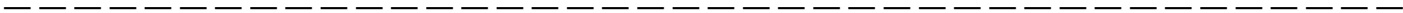
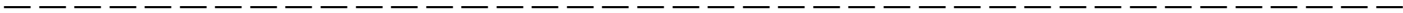
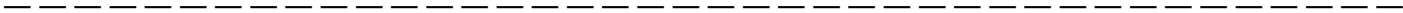
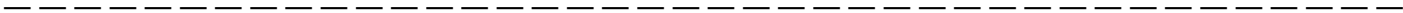
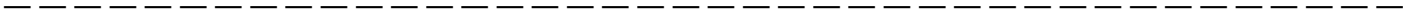

## Table of contents

<i>Seat, seatbelt and SRS airbags</i>	<b>1</b>
<i>Keys and doors</i>	<b>2</b>
<i>Instruments and controls</i>	<b>3</b>
<i>Climate control</i>	<b>4</b>
<i>Audio</i>	<b>5</b>
<i>Interior equipment</i>	<b>6</b>
<i>Starting and operating</i>	<b>7</b>
<i>Driving tips</i>	<b>8</b>
<i>In case of emergency</i>	<b>9</b>
<i>Appearance care</i>	<b>10</b>
<i>Maintenance and service</i>	<b>11</b>
<i>Specifications</i>	<b>12</b>
<i>Consumer information and Reporting safety defects</i>	<b>13</b>
<i>Index</i>	<b>14</b>

## Illustrated index

### ■ Exterior

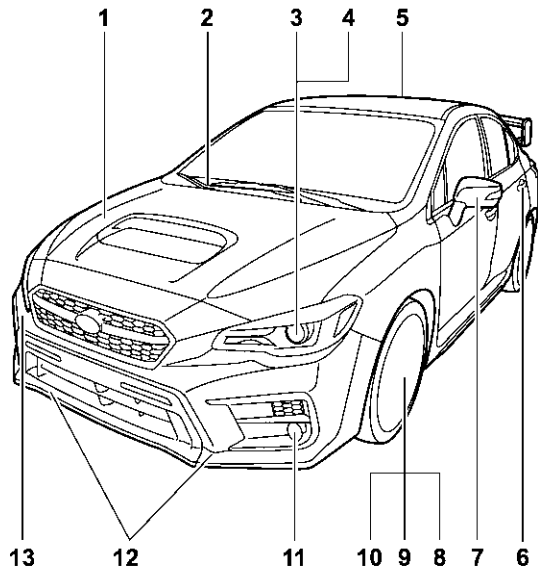

001457

- 1) Engine hood (page 11-9)
- 2) Front wipers (page 3-74)
- 3) Headlights (page 3-65)
- 4) Replacing bulbs (page 11-44)
- 5) Moonroof (page 2-38)
- 6) Door locks (page 2-4)
- 7) Outside mirrors (page 3-86)
- 8) Tire pressure (page 11-32)
- 9) Flat tires (page 9-4)
- 10) Snow tires (page 8-9)
- 11) Fog light (page 3-73)
- 12) Tie-down hooks (page 9-13)
- 13) Towing hook (page 9-13)

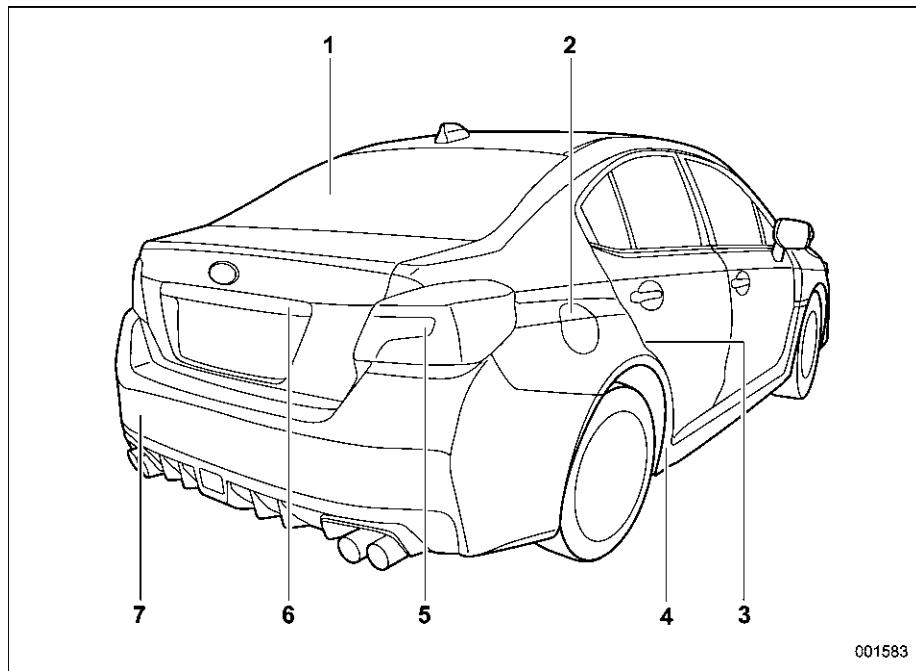

- 1) Rear window defogger (page 3-86)
- 2) Fuel filler lid and cap (page 7-5)
- 3) Child safety locks (page 2-31)
- 4) Tie-down hole (page 9-13)
- 5) Replacing bulbs (page 11-44)
- 6) Trunk lid (page 2-35)
- 7) Towing hook (page 9-13)

001583

## ■ Interior

### ▼ Passenger compartment area

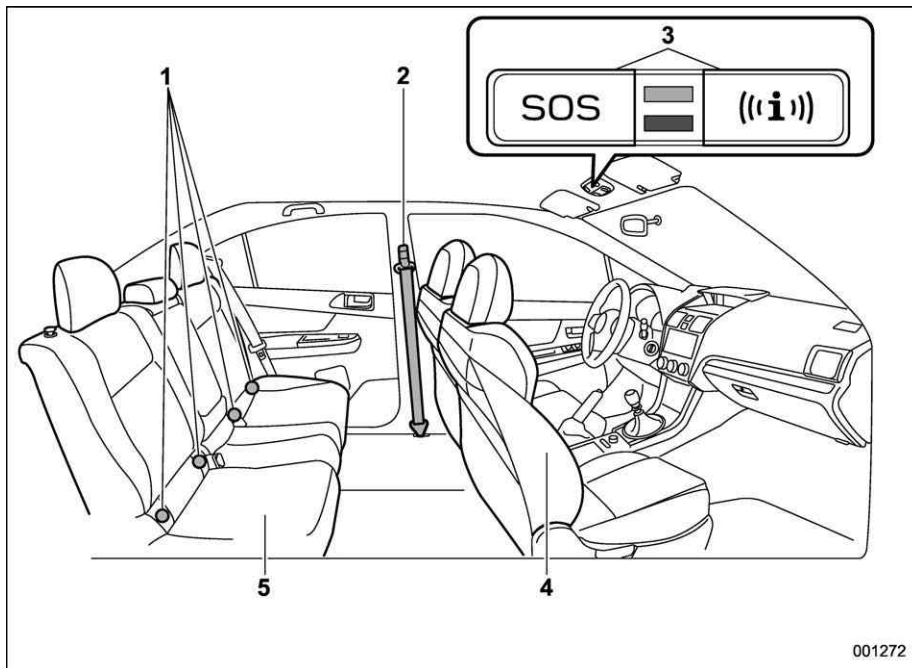

- 1) Lower anchorages for child restraint system (page 1-31)
- 2) Seatbelts (page 1-12)
- 3) Buttons for SUBARU STARLINK
- 4) Front seats (page 1-2)
- 5) Rear seats (page 1-8)

### NOTE

For models with SUBARU STARLINK:  
Refer to the Owner's Manual supplement for SUBARU STARLINK.

(STI)

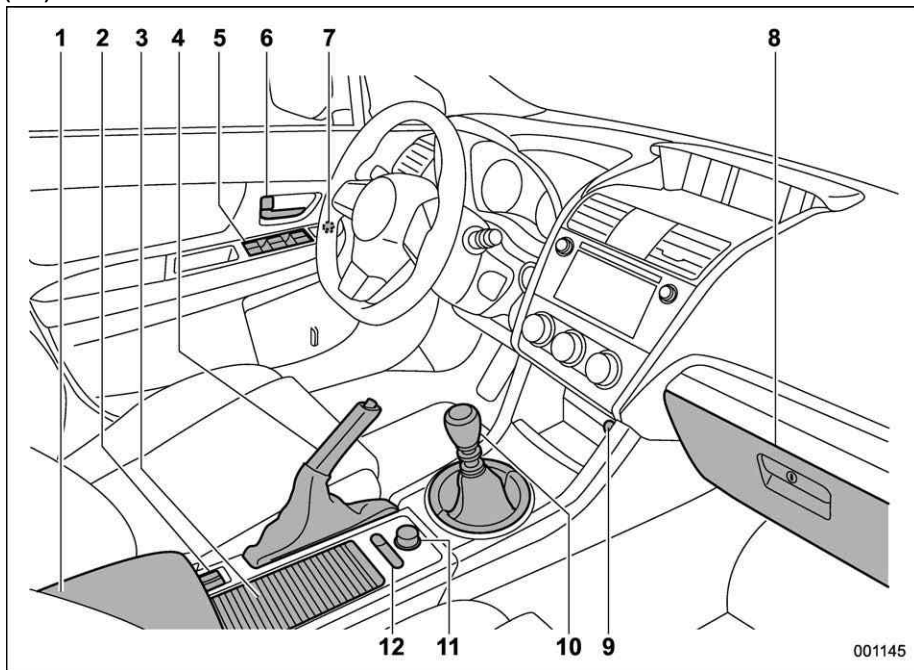

- 1) Center console (page 6-5)
- 2) Seat heater switches (if equipped) (page 1-7)
- 3) Cup holder (page 6-6)
- 4) Parking brake lever (page 7-42)
- 5) Power window switches (page 2-31)
- 6) Door locks (page 2-4)
- 7) Remote control mirror switch (page 3-86)
- 8) Glove box (page 6-5)
- 9) Front power supply socket (page 6-8)
- 10) Shift lever (page 7-16)
- 11) SI-DRIVE switches (page 7-28)
- 12) Driver's Control Center Differential (C.DIFF/DCCD) switches (page 7-19)

001145

(Except STI) (models without the EyeSight system)

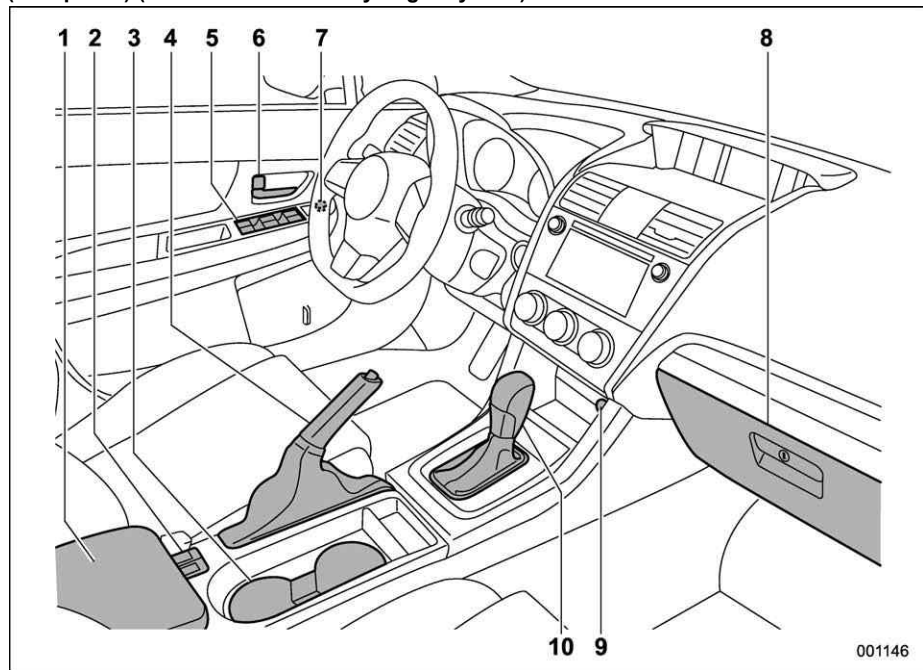

- 1) Center console (page 6-5)
- 2) Seat heater switches (if equipped) (page 1-7)
- 3) Cup holder (page 6-6)
- 4) Parking brake lever (page 7-42)
- 5) Power window switches (page 2-31)
- 6) Door locks (page 2-4)
- 7) Remote control mirror switch (page 3-86)
- 8) Glove box (page 6-5)
- 9) Front power supply socket (page 6-8)
- 10) Shift lever (MT) (page 7-16)/Select lever (CVT) (page 7-24)



(Except STI) (models with the EyeSight system)

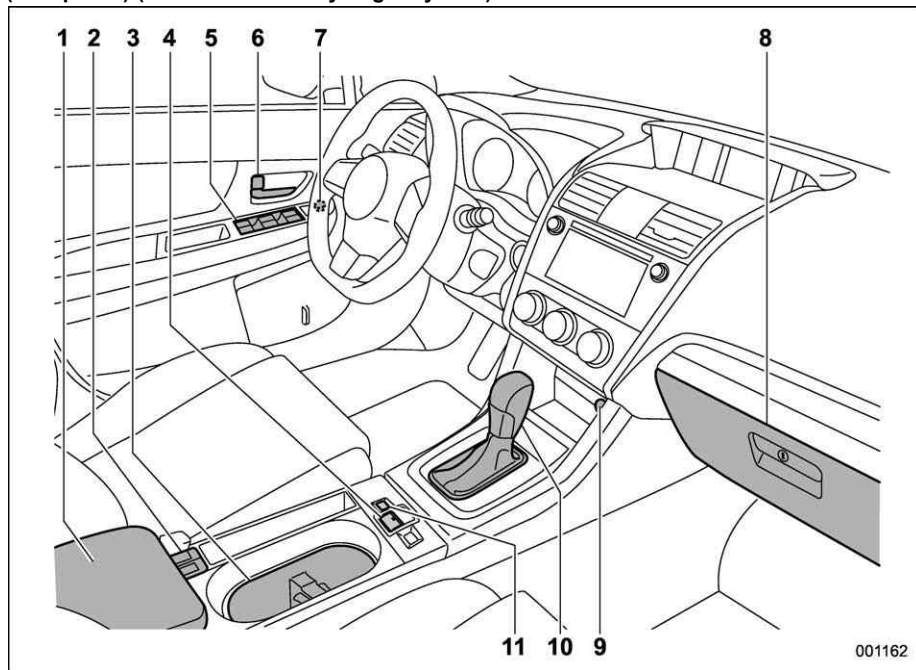

- 1) Center console (page 6-5)
- 2) Seat heater switches (if equipped) (page 1-7)
- 3) Cup holder (page 6-6)
- 4) Parking brake switch (page 7-42)
- 5) Power window switches (page 2-31)
- 6) Door locks (page 2-4)
- 7) Remote control mirror switch (page 3-86)
- 8) Glove box (page 6-5)
- 9) Front power supply socket (page 6-8)
- 10) Select lever (page 7-24)
- 11) Auto Vehicle Hold switch (page 7-47)

## ■ Instrument panel

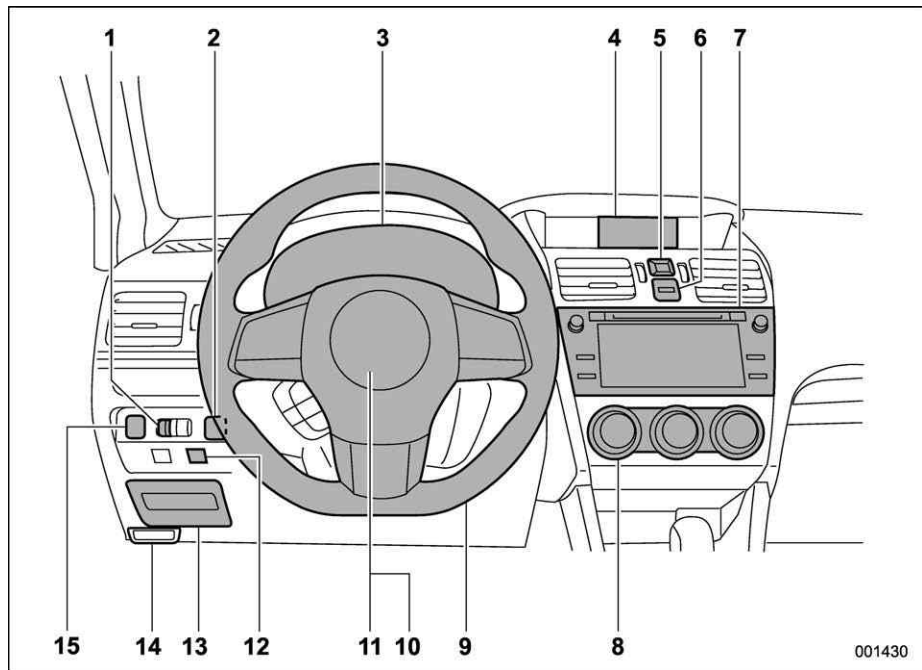

- 1) Illumination brightness control dial (page 3-72)
- 2) Trunk opener switch (page 2-35)
- 3) Combination meter (page 3-8)
- 4) Multi-function display (color LCD) (page 3-44)
- 5) Hazard warning flasher switch (page 3-8)
- 6) Multi-function display (color LCD) control switches (page 3-44)/View switch (page 6-15) (if equipped)
- 7) Audio\*
- 8) Climate control (page 4-1)
- 9) Tilt/telescopic steering (page 3-88)
- 10) Horn (page 3-88)
- 11) SRS airbag (page 1-35)
- 12) Vehicle Dynamics Control OFF switch (page 7-38)
- 13) Fuse box (page 11-42)
- 14) Hood release knob (page 11-9)
- 15) BSD/RCTA OFF switch (if equipped) (page 7-56)

\*: For details about how to use the audio and navigation system (if equipped), refer to the separate navigation/audio Owner's Manual.

### NOTE

**For models with the EyeSight system: Refer to the Owner's Manual supplement for the EyeSight system.**

001430

## ■ Steering wheel

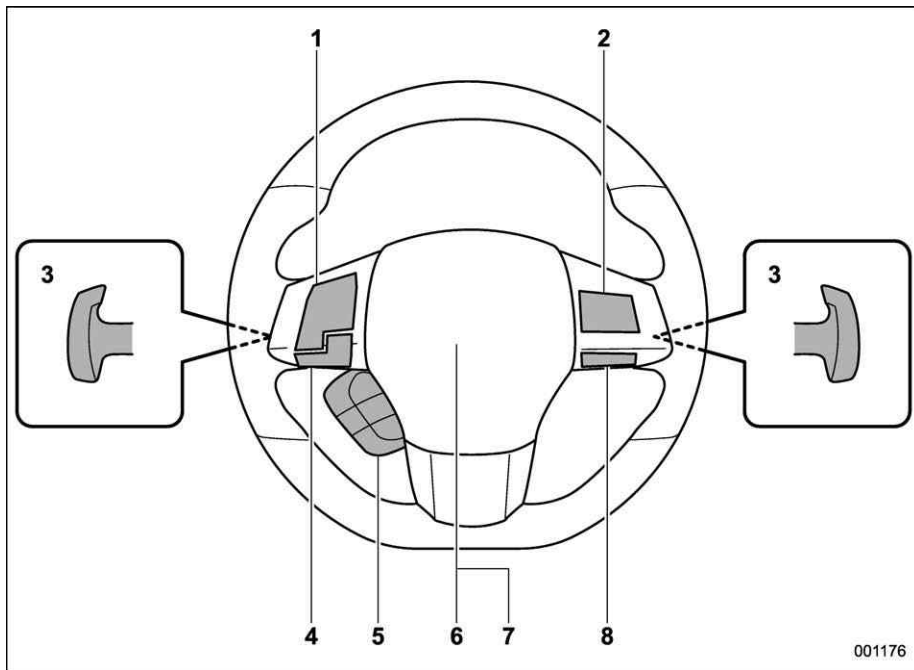

- 1) Audio control buttons\*
- 2) Cruise control (page 7-53)
- 3) Shift paddle (CVT models) (page 7-25)
- 4) Hands-free switches\*/Voice command system\*
- 5) Combination meter display (color LCD) control switches (page 3-37)
- 6) SRS airbag (page 1-35)
- 7) Horn (page 3-88)
- 8) SI-DRIVE switches (if equipped) (page 7-28)

\*: For details about how to use the switches, refer to the separate navigation/audio Owner's Manual.

## ■ Light control and wiper control levers/switches

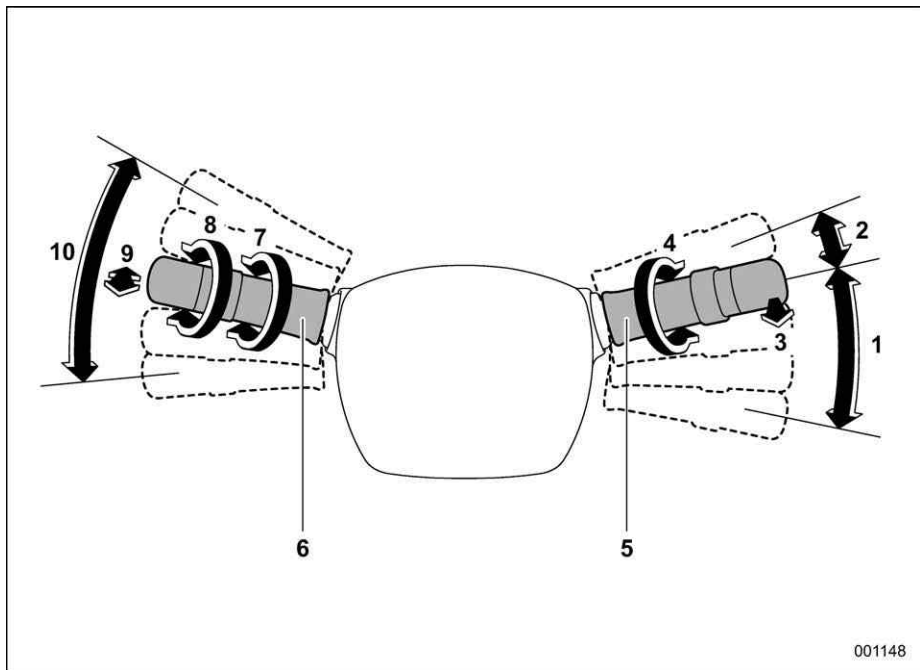

- 1) Windshield wiper (page 3-74)
- 2) Mist (page 3-75)
- 3) Windshield washer (page 3-76)
- 4) Wiper intermittent time control switch (page 3-76)
- 5) Wiper control lever (page 3-75)
- 6) Light control switch (page 3-65)
- 7) Fog light switch (if equipped) (page 3-73)
- 8) Headlight ON/OFF/AUTO (page 3-65)
- 9) Headlight flasher High/Low beam change (page 3-67)
- 10) Turn signal lever (page 3-72)

## ■ Combination meter

### ▼ U.S.-spec. models

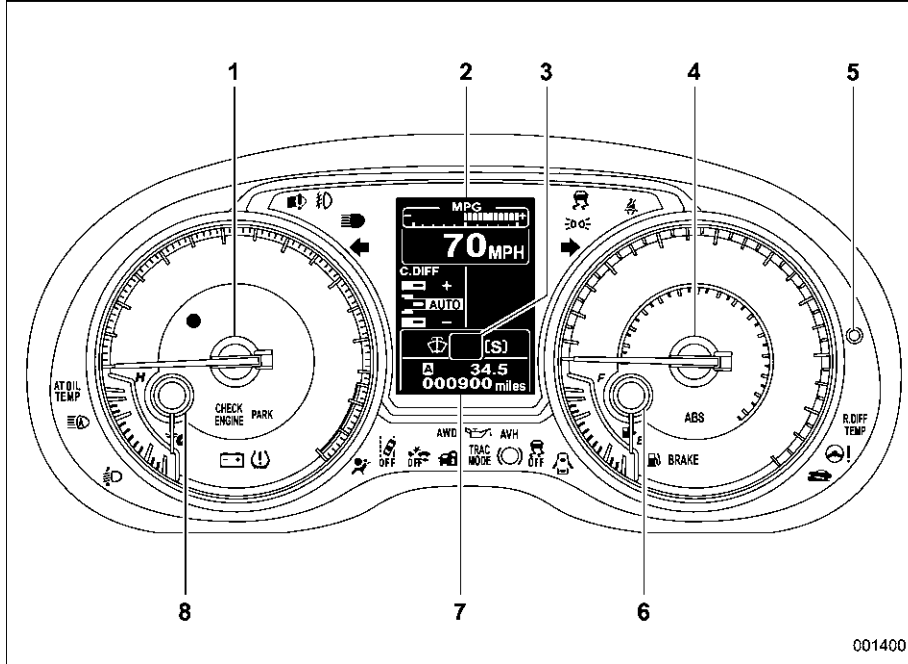

- 1) Tachometer (page 3-10)
- 2) Combination meter display (color LCD) (page 3-37)
- 3) Select lever/gear position indicator (page 3-34)
- 4) Speedometer (page 3-9)
- 5) Trip knob (page 3-9)
- 6) Fuel gauge (page 3-10)
- 7) Trip meter and odometer (page 3-9)
- 8) Temperature gauge (page 3-11)

The illustration above is a typical example. For some models, the combination meter may be slightly different than that shown in the illustration.

001400



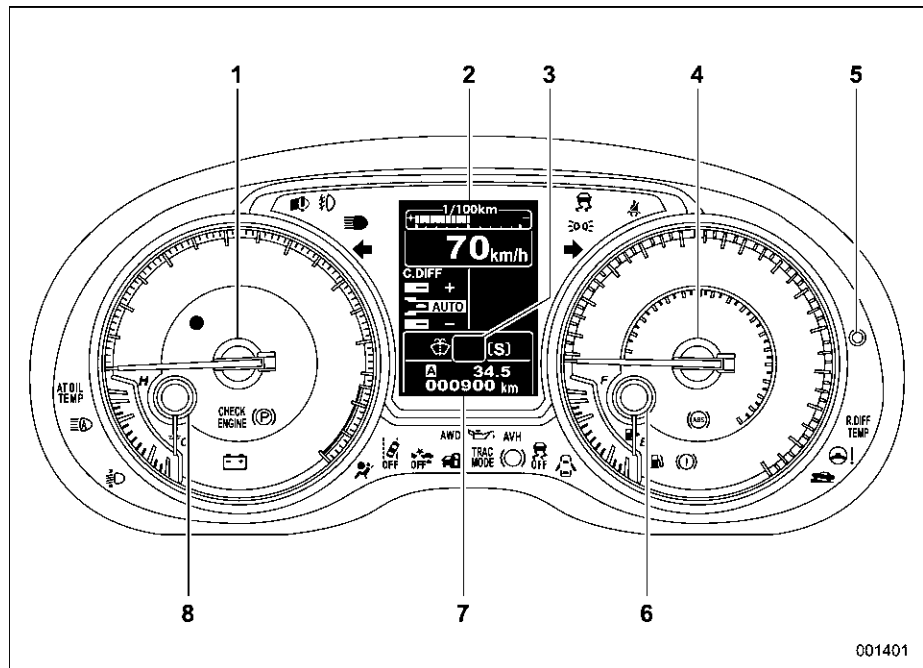





## ▼ Except U.S.-spec. models













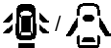



- 1) Tachometer (page 3-10)
- 2) Combination meter display (color LCD) (page 3-37)
- 3) Select lever/gear position indicator (page 3-34)
- 4) Speedometer (page 3-9)
- 5) Trip knob (page 3-9)
- 6) Fuel gauge (page 3-10)
- 7) Trip meter and odometer (page 3-9)
- 8) Temperature gauge (page 3-11)











The illustration above is a typical example. For some models, the combination meter may be slightly different than that shown in the illustration.











## ■ Warning and indicator lights



Mark	Name	Page
	Seatbelt warning light	3-14
PASSENGER 	Front passenger's seatbelt warning light	3-14
	SRS airbag system warning light	3-15
ON / 	Front passenger's frontal airbag ON indicator	3-16
OFF / 	Front passenger's frontal airbag OFF indicator	3-16
CHECK ENGINE	CHECK ENGINE warning light/Mal-function indicator light	3-16
	Charge warning light	3-17
	Oil pressure warning light	3-17
	Engine low oil level warning indicator (except STI)	3-17
AT OIL TEMP	AT OIL TEMP warning light (CVT models)	3-18

Mark	Name	Page
R.DIFF TEMP	Rear differential oil temperature warning light (STI)	3-18
ABS / 	ABS warning light	3-20
BRAKE / 	Brake system warning light	3-21
PARK / 	Electronic parking brake indicator light (models with electronic parking brake system)	3-22
	Door open warning light	3-25
AWD	AWD warning light (if equipped)	3-25
	Power steering warning light (except STI)	3-25
	Hill start assist warning light/Hill start assist OFF indicator light (models without electronic parking brake system)	3-24
AVH	Auto Vehicle Hold ON indicator light (models with electronic parking brake system)	3-24

Mark	Name	Page
	Auto Vehicle Hold operation indicator light (models with electronic parking brake system)	3-24
	Vehicle Dynamics Control warning light/ Vehicle Dynamics Control operation indicator light	3-26
	Vehicle Dynamics Control OFF indicator light	3-27
	Turn signal indicator lights	3-35
	LED headlight warning light (if equipped)	3-26
	High beam indicator light	3-35
	High Beam Assist indicator light (if equipped)	3-35
	Automatic headlight beam leveler warning light (models with LED headlights)	3-35
	Front fog light indicator light (if equipped)	3-35

Mark	Name	Page
	Access key warning light (if equipped)	3-28
	Security indicator light	3-33
	Headlight indicator light	3-35
	Cruise control indicator	3-35
	Cruise control set indicator	3-35
	Traction mode indicator	3-27
	Low fuel warning light	3-24
	Low tire pressure warning light (U.S.-spec. models)	3-18
	Windshield washer fluid warning indicator	3-18
	Sport (S) mode indicator (if equipped)	3-34
	Intelligent (I) mode indicator (if equipped)	3-34

Mark	Name	Page
	Sport Sharp (S#) mode indicator (if equipped)	3-34
	Shift-up indicator (STI)	3-34
	Driver's control center differential auto indicator (STI)	3-36
	Auto [+] mode indicator (STI)	3-36
	Auto [-] mode indicator (STI)	3-36
	Driver's control center differential indicator and warning (STI)	3-36
	REV indicator light (STI)	3-37
	Steering Responsive Headlight warning indicator/Steering Responsive Headlight OFF indicator (if equipped)	3-37
	BSD/RCTA warning indicator (if equipped)	3-37
	BSD/RCTA OFF indicator (if equipped)	3-37

Mark	Name	Page
	RAB warning indicator (if equipped)	3-37
	RAB OFF indicator (if equipped)	3-37



## Function settings

### ■ Function settings and adjustments on the multi-function display (color LCD)

Setting adjustments to the following items can be manually changed within the multi-function display (color LCD) to meet your personal requirements.

Item	Function	Available settings	Factory default setting	Page
Keyless access (if equipped)	Hazard warning flasher	Operation/Non-operation	Operation	2-11
	Audible signal volume	0 (OFF) to 7	Level 5	2-14
	Door unlock selection function (driver's door unlock)	Driver's door only/All doors	Driver's door only	2-12
Remote keyless entry system	Hazard warning flasher	Operation/Non-operation	Operation	2-18
	Audible signal volume	0 (OFF) to 7	Level 5	2-20
Defogger and deicer system for models with the automatic climate control system	Rear window defogger, outside mirror defogger and windshield wiper deicer	Operation for 15 minutes/Continuous operation	Operation for 15 minutes	3-86
Auto on/off headlights (if equipped)	Sensitivity of the operation of the auto on/off headlights	Low/Normal/High/Very high	Normal	3-65
Dome light	Operation of dome light/map light OFF delay timer	OFF/10 seconds/20 seconds/30 seconds	30 seconds	6-3
Map light (models with moonroof)				
Welcome lighting	Approaching (operation of timer)	OFF/30 seconds/60 seconds/90 seconds	30 seconds	3-66
	Exiting (operation of timer)			

## ■ Individual settings and adjustments excluding multi-function display (color LCD)

For setting adjustments to the following items, refer to the appropriate page for details.

Item	Function	Available settings	Factory default setting	Page
Alarm system	Alarm system	Operation/Non-operation	Operation	2-24
Remote keyless entry system	Audible signal	Operation/Non-operation	Operation	2-20

## ■ Function settings and adjustments performed by a dealer

A SUBARU dealer can change the setting adjustments of the following items to meet your personal requirements. Contact the nearest SUBARU dealer for details.

Item	Function	Available settings	Factory default setting	Page
Alarm system	Monitoring start delay time (after closure of doors)	0 seconds/30 seconds	30 seconds	2-25
	Impact sensor operation (only models with shock sensors (dealer option))	Operation/Non-operation	Non-operation	2-30
	Passive arming (models without "keyless access with push-button start system")	Operation/Non-operation	Non-operation	2-29
	Dome light and map lights (models with moonroof illumination)	ON/OFF	OFF	2-24
Keyless access with push-button	Trunk open without key	ON/OFF	ON	2-11
Remote trunk open function	Activation of trunk opening by remote transmitter/access key fob	Operation/Non-operation	Operation	2-20
Key lock-in prevention	Key lock-in prevention	Operation/Non-operation	Operation	2-7
Battery drainage prevention function	Battery drainage prevention function	Operation/Non-operation	Operation	2-5
Seatbelt warning	Sounds a chime while driving	Operation/Non-operation	Operation	3-14
Windshield wiper	Auto-on/off wiper linked headlights	Operation/Non-operation	Operation	3-66

Item	Function	Available settings	Factory default setting	Page
Auto dimmer cancel	Sensitivity of the operation of the auto dimmer cancel	OFF/Min/Low/Mid/Hi/Max	Mid	3-73
High beam assist function (models with the EyeSight system)	High beam assist function	Operation/Non-operation	Operation	3-67
One-touch lane changer	Operation of the one-touch lane changer	Operation/Non-operation	Operation	3-72

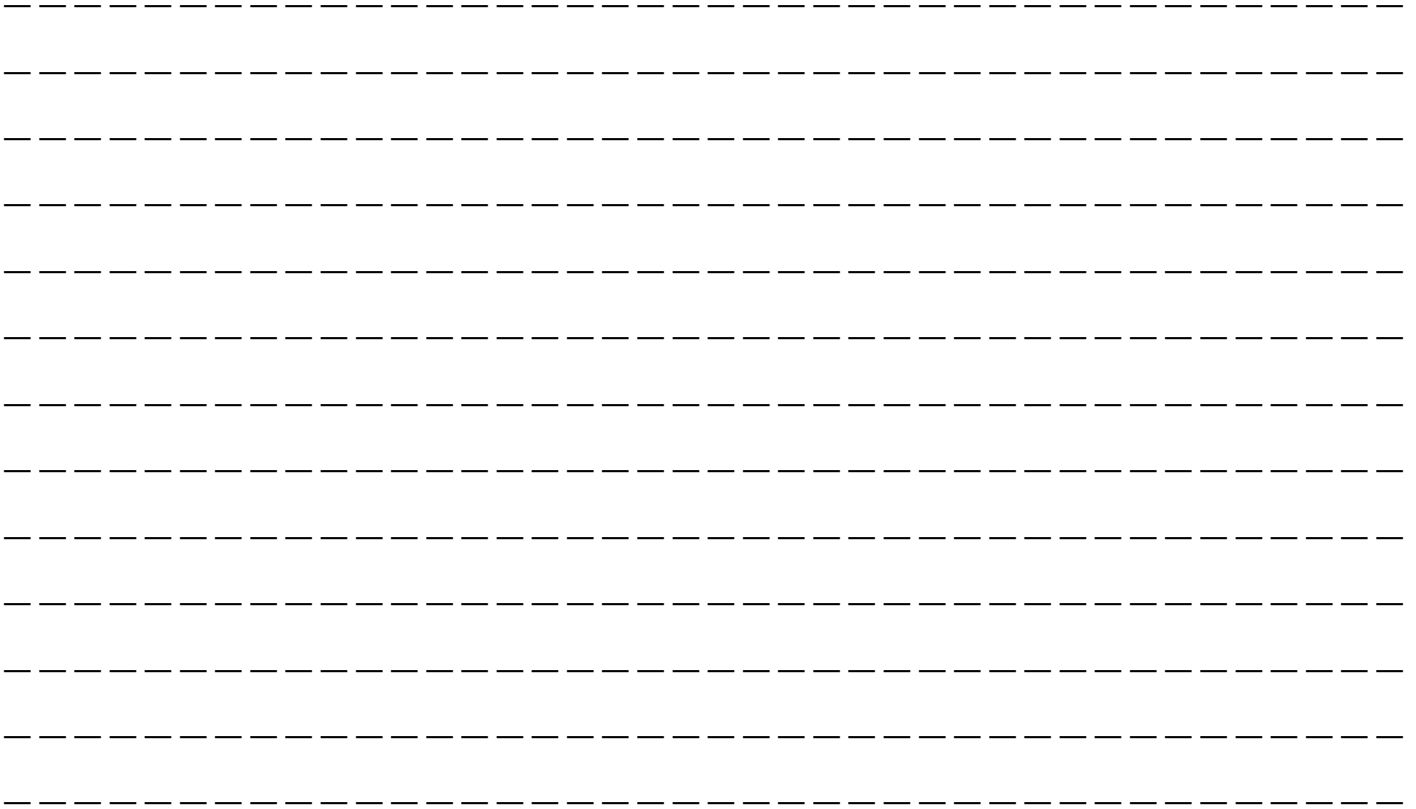

# Seat, seatbelt and SRS airbags

Front seats .....	1-2
Manual seat .....	1-4
Power seat (driver's seat – if equipped).....	1-5
Head restraint adjustment .....	1-5
Seat heater (if equipped).....	1-7
Rear seats.....	1-8
Head restraint adjustment .....	1-8
Folding down the rear seatback .....	1-9
Armrest .....	1-11
Seatbelts.....	1-12
Seatbelt safety tips .....	1-12
Emergency Locking Retractor (ELR).....	1-13
Automatic Locking Retractor/Emergency Locking Retractor (ALR/ELR) .....	1-13
Seatbelt warning light and chime .....	1-13
Fastening the seatbelt.....	1-13
Seatbelt maintenance.....	1-17
Front seatbelt pretensioners.....	1-17
Driver's seatbelt.....	1-17
Front passenger's seatbelt.....	1-18
Components that will operate with the seatbelt pretensioner(s) simultaneously .....	1-19
Safety tips .....	1-20
System monitors.....	1-20
System servicing .....	1-20
Precautions against vehicle modification.....	1-21

Child restraint systems.....	1-21
Safety precautions.....	1-21
Safety tips for installing child restraint systems....	1-22
Where to place a child restraint system .....	1-23
Choosing a child restraint system.....	1-25
Installing child restraint systems with ALR/ELR seatbelt .....	1-25
Installing a booster seat or booster cushion .....	1-30
Installation of child restraint systems by use of lower and tether anchorages (LATCH).....	1-31
Top tether anchorages .....	1-34
SRS airbag (Supplemental Restraint System airbag) .....	1-35
General precautions regarding SRS airbag system .....	1-36
General precautions regarding SRS airbag system for accessories and any objects.....	1-38
General precautions regarding SRS airbag system for children.....	1-40
Components .....	1-43
SUBARU advanced frontal airbag system.....	1-45
SRS side airbag and SRS curtain airbag .....	1-55
SRS airbag system monitors.....	1-64
SRS airbag system servicing .....	1-65
Precautions against vehicle modification .....	1-66
How to contact the vehicle manufacturer concerning modifications for persons with disabilities that may affect the advanced airbag system .....	1-67

## Front seats

### WARNING

- Never adjust the seat while driving, as personal injury or loss of vehicle control may occur.
- Before adjusting the seat, ensure nothing is blocking the adjusting mechanism.
- After adjusting the seat, move it back and forth to ensure the seat is securely locked. If it is not, it may move suddenly or the seatbelt may not operate properly.
- Do not put objects under the front seats. They may interfere with front seat locking mechanism and cause an accident.
- Seatbelts provide maximum restraint when the occupant sits back and upright in the seat. To reduce the risk of sliding under the seatbelt in a collision, the front seatbacks should always be used in the upright position while the vehicle is running. If the front seatbacks are not in the upright position and a collision occurs, the risk of sliding under the lap belt and of the lap belt

sliding up over the abdomen will increase, and both can result in serious injury or death.

- The SRS airbags deploy with considerable speed and force. Occupants who are not sitting back and upright when the SRS airbag deploys could suffer serious injury. Because the SRS airbag needs enough space for deployment, the driver should always sit upright and well back in the seat as far from the steering wheel as practical while still maintaining full vehicle control, and the front passenger should move the seat as far back as possible and sit upright and well back in the seat.



### WARNING

Place children in the rear seat properly restrained at all times. The SRS airbag deploys with considerable speed and force and can injure or even kill children, especially if they are not restrained or improperly restrained. Because children are lighter and weaker than adults, their risk of being injured from deployment is greater. For that reason, we strongly recommend that ALL children (including those in child seats and those that have outgrown child restraint devices) sit in the REAR seat properly restrained at all times in a child restraint device or in a seatbelt, whichever is appropriate

for the child's age, height and weight. Secure ALL types of child restraint devices (including forward facing child seat) in the REAR seats at all times.

**NEVER INSTALL A CHILD SEAT IN THE FRONT SEAT. DOING SO RISKS SERIOUS INJURY OR DEATH TO THE CHILD BY PLACING THE CHILD'S HEAD TOO CLOSE TO THE SRS AIRBAG.**

According to accident statistics, children are safer when properly restrained in the rear seating positions than in the front seating positions. For instructions and precautions concerning child restraint systems, refer to "Child restraint systems" 1-21.

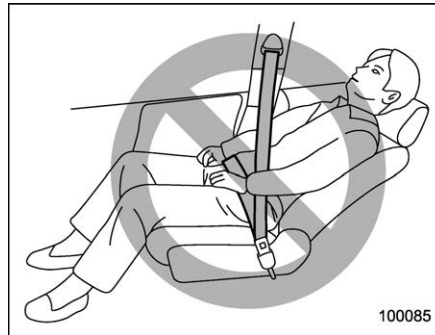

100085

**⚠ WARNING**

To prevent the passenger from sliding under the seatbelt in the event of a collision, observe the following precautions:

- Keep the seatback in the upright position while the vehicle is in motion.
- Do not place objects such as cushions between the passenger and the seatback.

Otherwise, the risk of sliding under the lap belt and of the lap belt sliding up over the abdomen will increase, and both can result in serious injury or death.

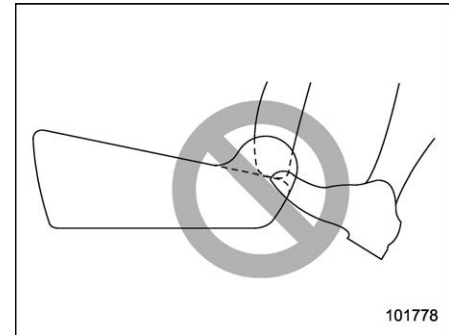

101778

**⚠ WARNING**

Do not let rear passengers rest their feet between the front seatback and seat cushion. Doing so may lead to improper operation of the following systems and could result in serious injury.

- Occupant detection system
- SRS side airbag
- Seat heater (if equipped)
- Power seat (if equipped)

## Manual seat

### Forward and backward adjustment

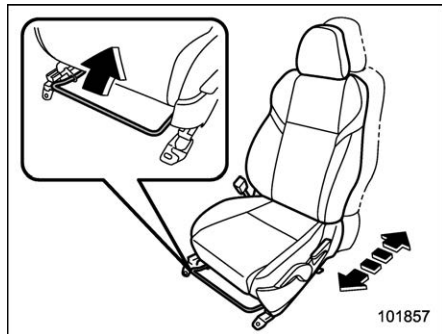

1. Sit in the seat to adjust.
2. Pull the lever upward, slide the seat to the desired position, and then release the lever.
3. Try to move the seat back and forth to make sure that it is securely locked into place.

### Reclining the seatback

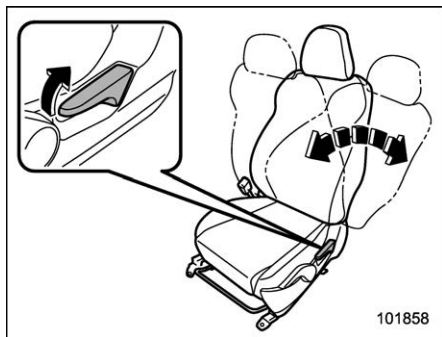

1. Pull up the reclining lever, adjust the seatback to the desired position, and then release the lever.
2. Make sure the seatback is securely locked into place.

The seatback placed in a reclined position can spring back upward with force when pulling the lever. While operating the lever to return the seatback, hold the seatback lightly so that it may be raised back gradually.

### Seat cushion height adjustment (driver's seat)

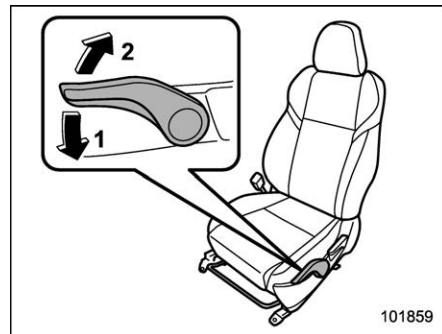

- 1) When the lever is pushed down, the seat is lowered.
- 2) When the lever is pulled up, the seat rises.

Move the seat cushion adjustment lever up or down to adjust the seat cushion height.



## ■ Power seat (driver's seat – if equipped)

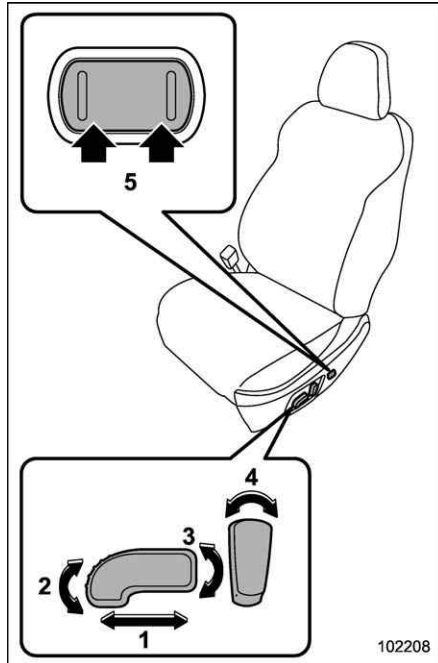

### 1) Seat position forward/backward control switch

To adjust the seat forward or backward, move the control switch forward or backward. During forward/backward ad-

justment of the seat, you cannot adjust the seat cushion angle or seat cushion height.

- 2) **Seat cushion angle control switch**  
To adjust the seat cushion angle, pull up or push down the front end of the control switch.
- 3) **Seat height control switch**  
To adjust the seat height, pull up or push down the rear end of the control switch.
- 4) **Seatback angle (reclining) control switch**  
To adjust the angle of the seatback, move the control switch.
- 5) **Lumbar support control switch (driver's seat only)**  
To increase lower back support, push the front side of the switch. To decrease lower back support, push the rear side of the switch.

## ■ Head restraint adjustment



### WARNING

- Never drive the vehicle with the head restraints removed because they are designed to reduce the risk of serious neck injury in the event that the vehicle is struck from the rear. Also, never install the head restraints the opposite way round. Doing so will prevent the head restraints from function-

ing as intended. Therefore, when you remove the head restraints, you must reinstall all head restraints correctly to protect vehicle occupants.

- All occupants, including the driver, should not operate a vehicle or sit in a vehicle's seat until the head restraints are placed in their proper positions in order to minimize the risk of neck injury in the event of a crash.
- The front seat head restraints are designed to be installed into the front seats only. The rear seat head restraints are designed to be installed into the rear seats only. Do not attempt to install the front seat head restraints into the rear seats, or the rear seat head restraints into the front seats.

## NOTE

It is possible to adjust the angle of the front seat head restraints only. When installing the front seat head restraints, make sure that the angle of the head restraints can be adjusted.

Both the driver's seat and front passenger's seat are equipped with head restraints. Both head restraints are adjusta-

ble in the following ways.

▼ **Head restraint height adjustment**

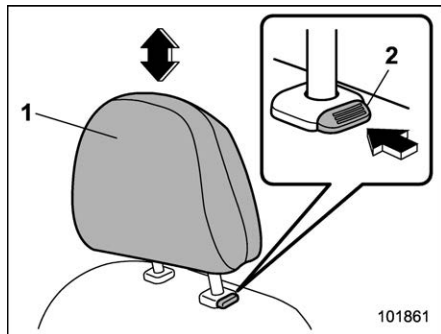

- 1) Head restraint
- 2) Release button

**To raise:**

Pull the head restraint up.

**To lower:**

Push the head restraint down while pressing the release button on the top of the seatback.

**To remove:**

While pressing the release button, pull out the head restraint.

**To install:**

Install the head restraint into the holes that are located on the top of the seatback until the head restraint locks. Press and hold

the release button to lower the head restraint.

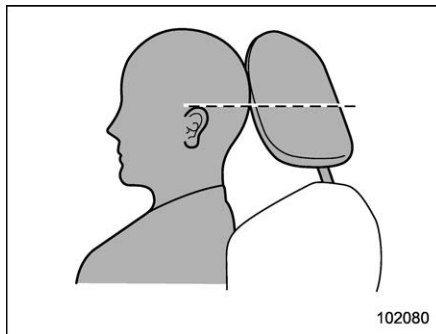

Adjust each head restraint so that the center of the head restraint is closest to the top of the occupant's ears.

**NOTE**

**When the head restraint will not move in or out due to insufficient clearance between the head restraint and the roof, tilt the seat and then perform the installation and removal tasks.**

▼ **Head restraint angle adjustment**

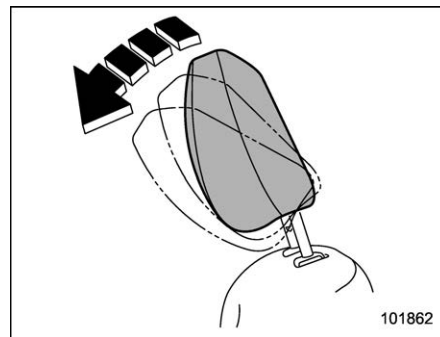

It is possible to adjust the angle of the head restraint in several steps. While maintaining a suitable driving posture, adjust the head restraint to a position where the back of your head is as close to the head restraint as possible.

**To tilt:**

Tilt the head restraint by hand to the preferred position. A click will be audible when the head restraint is locked.

**To return:**

Tilt the head restraint once as far forward as it can go. The head restraint will automatically return to the fully upright position. Then, adjust the head restraint again to the preferred angle.

## Seat heater (if equipped)

The front seats are equipped with a seat heater.

The seat heater operates when the ignition switch is either in the “ACC” or “ON” position.

### CAUTION

- People with delicate skin may suffer slight burns even at low temperatures if they use the seat heater for a long period of time. When using the heater, always be sure to warn the persons concerned.
- Do not put anything on the seat which insulates against heat, such as a blanket, cushion, or similar items. This may cause the seat heater to overheat.
- When the seat is warmed enough or before you leave the vehicle, be sure to turn off the seat heater.

### NOTE

Use of the seat heater for a long period of time while the engine is not running can cause battery discharge.

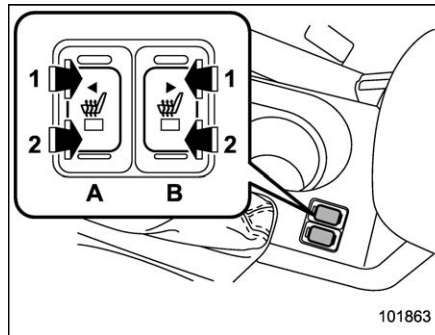

Type A

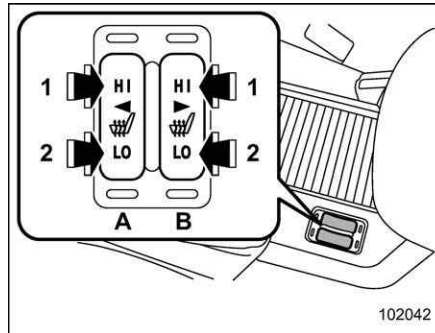

Type B

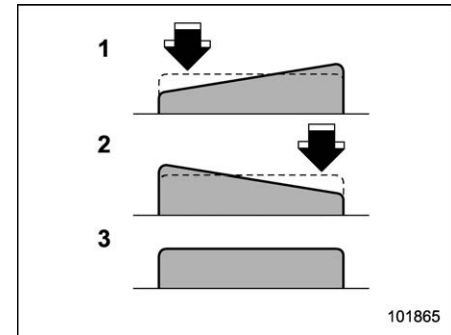

- 1) **HIGH (HI)** – Rapid heating
  - 2) **LOW (LO)** – Normal heating
  - 3) Off
- A) Left-hand side  
B) Right-hand side

To turn on the seat heater, push the “LOW” (“LO”) or “HIGH” (“HI”) position on the switch, as desired, depending on the temperature.

Selecting the “HIGH” (“HI”) position will cause the seat to heat up quicker.

To turn off the seat heater, lightly press the opposite side of the current position.

The indicator located on the switch illuminates when the seat heater is in operation. When the seat is warmed enough or before you leave the vehicle, be sure to turn the switch off.

## Rear seats

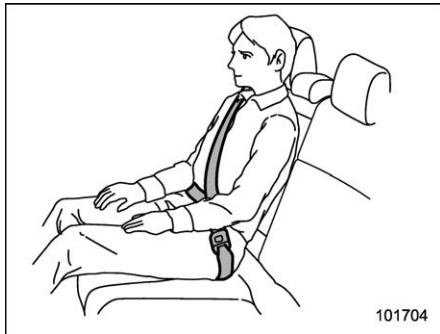

### ⚠ WARNING

Seatbelts provide maximum restraint when the occupant sits back and upright in the seat. Do not place cushions or any other materials between occupants and seatbacks or seat cushions. By doing so, the risk of sliding under the lap belt and of the lap belt sliding up over the abdomen will increase, and both can result in serious injury or death.

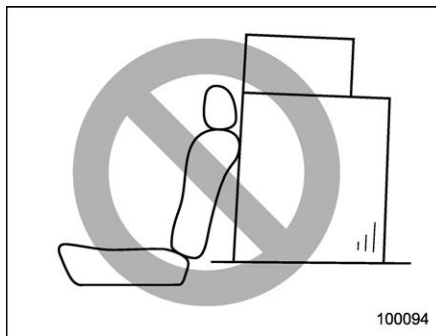

### ⚠ WARNING

Never stack luggage or other cargo higher than the top of the seatback as it could tumble forward and injure passengers in the event of a sudden stop or accident.

### ■ Head restraint adjustment

Both the rear window side seats and the rear center seat are equipped with head restraints.

### ⚠ WARNING

- Never drive the vehicle with the head restraints removed because they are designed to reduce the

risk of serious neck injury in the event that the vehicle is struck from the rear. Therefore, when you have removed the head restraints, you must reinstall all head restraints to protect vehicle occupants.

- All occupants, including the driver, should not operate a vehicle or sit in a vehicle's seat until the head restraints are placed in their proper positions in order to minimize the risk of neck injury in the event of a crash.

### ▼ Rear windows side seating position

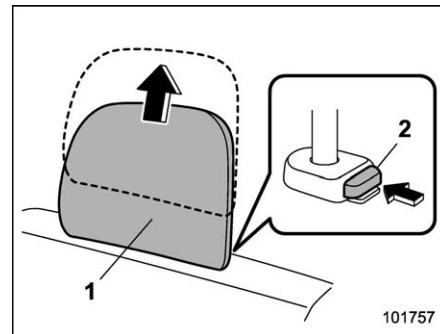

- 1) Head restraint
- 2) Release button

**To remove:**

While pressing the release button, pull out the head restraint.

**To install:**

Install the head restraint into the holes that are located on the top of the seatback until the head restraint locks. Press and hold the release button to lower the head restraint.

After installing the head restraint, make sure it is securely locked.

**NOTE**

**When the head restraint cannot be pulled out or installed due to insufficient clearance between the head restraint and the roof, tilt the seat and then perform the installation and removal tasks.**

▼ **Rear center seating position**

**CAUTION**

The head restraint is not intended to be used in the retracted position. Before sitting on the seat, raise the head restraint to the extended position.

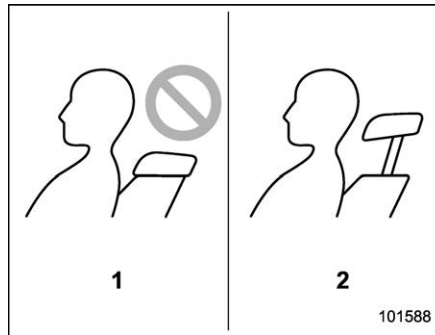

- 1) Incorrect (retracted position)
- 2) Correct (extended position)

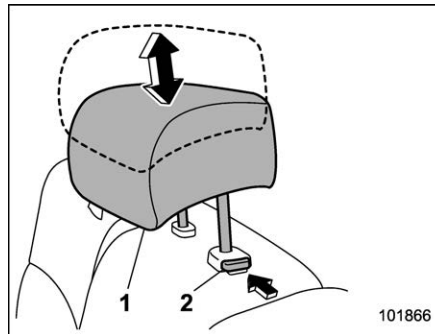

- 1) Head restraint
- 2) Release button

**To raise:**

Pull the head restraint up.

**To lower:**

Push the head restraint down while pressing the release button on the top of the seatback.

**To remove:**

While pressing the release button, pull out the head restraint.

**To install:**

Install the head restraint into the holes that are located on the top of the seatback until the head restraint locks. Press and hold the release button to lower the head restraint.

When the rear-center seating position is occupied, raise the head restraint to the extended position. When the rear center seating position is not occupied, lower the head restraint to improve rearward visibility.

**Folding down the rear seat-back**

**WARNING**

- When you fold down the seat-back, check that there are no passengers or objects on the rear seat. Not doing so creates a risk of injury or property damage if the seatback suddenly folds

down.

- Never allow passengers to ride on the folded rear seatback or in the trunk. Doing so may result in serious injury or death.
- Secure all objects and especially long items properly to prevent them from being thrown around inside the vehicle and causing serious injury during a sudden stop, steering maneuver or acceleration.
- When you return the seatback to its original position, shake it slightly to confirm that it is securely in place. If it is not securely fixed in place, it may suddenly fold down in the event of sudden braking, or objects may move out from the trunk. Both could cause serious injury or death.

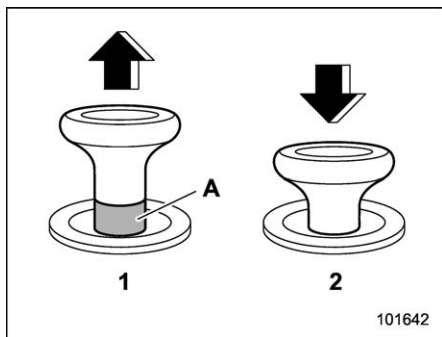

Lock release knob

- 1) Unlocked
- 2) Locked
- A) Unlocking marker in red

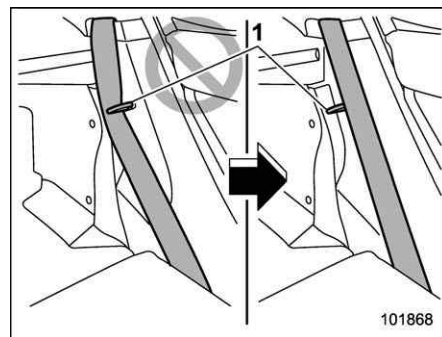
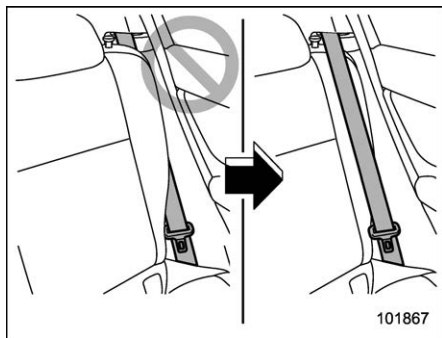

1) Striker

**WARNING**

When the seatback is returned to its original position, observe the following precautions. Failure to do so may lead to serious injury or an accident because the operation efficiency of the seatbelt is inhibited.

- The seatbelt should not be caught in the seatback and it should be fully visible.
- The seatbelt should not pass behind the securing hook for the seatback.

**CAUTION**

Do not hang luggage etc. on the securing hook. The possibility exists that the seatback may not be able to be fixed firmly in place. This could lead to unexpected accidents.

1. Lower the head restraint of the rear center seating position.

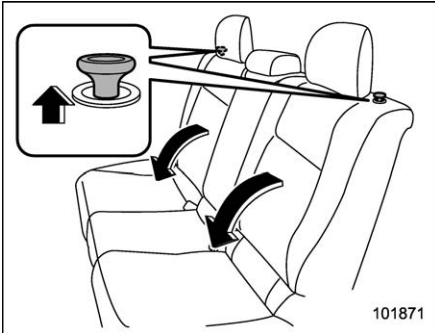

Release knob

2. Unlock the seatback by pulling the lock release knob then fold the seatback down.

To return the seatback to its original position, raise the seatback until it locks into place and make sure that the unlocking marker on the lock release knob is no longer visible.

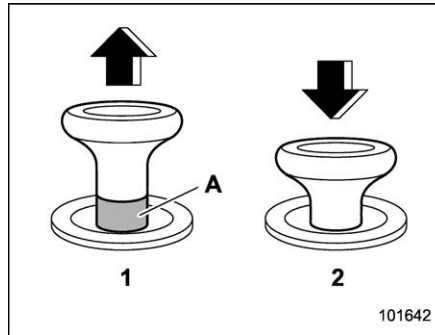

Lock release knob

- 1) Unlocked
  - 2) Locked
- A) Unlocking marker in red

**WARNING**

After returning the seatback to its original position, confirm that the unlocking marker of the lock release knob is no longer visible. Failure to do so could lead to serious injury or death in the event of an accident. When you return the seatback to its original position, shake the seatback to confirm that it is securely fixed in place.

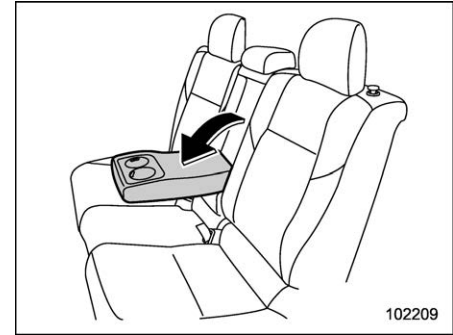
**Armrest**

To lower the armrest, pull the armrest's top edge.

**WARNING**

- Make sure to have the rear passengers wear the seatbelts before lowering the armrest. If the rear passengers wear the seatbelts after lowering the armrest, seatbelts cannot provide maximum restraint, causing serious injuries.
- To avoid serious injury, never allow passengers to sit on the center armrest while the vehicle is in motion.

## Seatbelts

### ■ Seatbelt safety tips

 **WARNING**

- All persons in the vehicle should fasten their seatbelts **BEFORE** the vehicle starts to move. Otherwise, the possibility of serious injury becomes greater in the event of a sudden stop or accident.
- All belts should fit snugly in order to provide full restraint. Loose fitting belts are not as effective in preventing or reducing injury.
- Each seatbelt is designed to support only one person. Never use a single belt for two or more persons – even children. Otherwise, in an accident, serious injury or death could result.
- Replace all seatbelt assemblies including retractors and attaching hardware worn by occupants of a vehicle that has been in a serious accident. Also, be sure to replace seatbelt assemblies that show signs of severe fraying or having been cut. The entire assembly should be replaced even

if damage is not obvious.

- Place children in the rear seat properly restrained at all times. The SRS airbag deploys with considerable speed and force and can injure or even kill children, especially if they are not restrained or improperly restrained. Because children are lighter and weaker than adults, their risk of being injured from deployment is greater. For that reason, we strongly recommend that **ALL** children (including those in child seats and those that have outgrown child restraint devices) sit in the **REAR** seat properly restrained at all times in a child restraint device or in a seatbelt, whichever is appropriate for the child's height and weight.

Secure **ALL** types of child restraint devices (including forward facing child seats) in the **REAR** seats at all times.

**NEVER INSTALL A CHILD SEAT IN THE FRONT SEAT. DOING SO RISKS SERIOUS INJURY OR DEATH TO THE CHILD BY PLACING THE CHILD'S HEAD TOO CLOSE TO THE SRS AIRBAG.**

**According to accident statistics, children are safer when properly restrained in the rear seating positions than in the front seating positions. For instructions and precautions concerning the child restraint system, refer to "Child restraint systems" 1-21.**

Your vehicle is equipped with a crash sensing and diagnostic module, which will record the use of the seatbelt by the front passenger when any of the SRS frontal, side and curtain airbags deploy.

#### ▼ **Infants or small children**

Use a child restraint system that is suitable for your vehicle. Refer to "Child restraint systems" 1-21.

#### ▼ **Children**

If a child is too big for a child restraint system, the child should sit in the rear seat and be restrained using the seatbelts. According to accident statistics, children are safer when properly restrained in the rear seating positions than in the front seating positions. Never allow a child to stand up or kneel on the seat.

If the shoulder portion of the belt crosses the face or neck, move the child closer to the belt buckle to help provide a good



shoulder belt fit. Take care to securely place the lap belt as low as possible on the hips and not on the child's waist. If the shoulder portion of the belt cannot be properly positioned, use a child restraint system. Never place the shoulder belt under the child's arm or behind the child's back.

#### ▼ Expectant mothers

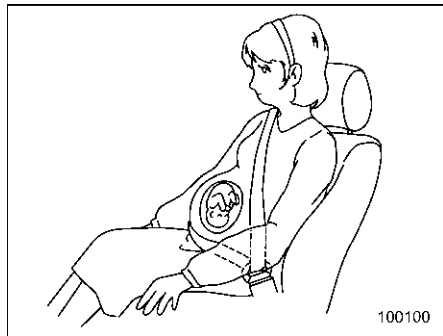

Expectant mothers also need to use the seatbelts. They should consult their doctor for specific recommendations. The lap belt should be worn securely and as low as possible over the hips, not over the waist.

### ■ Emergency Locking Retractor (ELR)

The driver's seatbelt has an Emergency Locking Retractor (ELR).

The emergency locking retractor allows normal body movement but the retractor locks automatically during a sudden stop, impact or if you pull the belt very quickly out of the retractor.

### ■ Automatic Locking Retractor/ Emergency Locking Retractor (ALR/ELR)

Each passenger's seatbelt has an Automatic Locking Retractor/Emergency Locking Retractor (ALR/ELR). The Automatic Locking Retractor/Emergency Locking Retractor normally functions as an Emergency Locking Retractor (ELR). The ALR/ELR has an additional locking mode "Automatic Locking Retractor (ALR) mode" intended to secure a child restraint system.

The ALR mode functions as follows.

When the seatbelt is once drawn out completely and is then retracted even slightly, the retractor locks the seatbelt in that position and the seatbelt cannot be extended. As the belt is rewinding, clicks will be heard which indicate the retractor functions as an ALR. When the seatbelt is

retracted fully, the ALR mode is released.

When securing a child restraint system on the rear seats by the use of the seatbelt, change the seatbelt over to the Automatic Locking Retractor (ALR) mode.

After removing the child restraint system, make sure that the seatbelt retracts fully and the retractor returned to the Emergency Locking Retractor (ELR) mode.

For instructions on how to convert the retractor to the ALR mode and restore it to the ELR mode, refer to "Installing child restraint systems with ALR/ELR seatbelt" 1-25.

### ■ Seatbelt warning light and chime



Refer to "Seatbelt warning light and chime" 3-14.

### ■ Fastening the seatbelt



#### WARNING

- **Never use a belt that is twisted or reversed. In an accident, this can increase the risk or severity of injury.**
- **Keep the lap belt as low as possible on your hips. In a colli-**

sion, this spreads the force of the lap belt over stronger hip bones instead of across the weaker abdomen.

- Seatbelts provide maximum restraint when the occupant sits well back and upright in the seat. To reduce the risk of sliding under the seatbelt in a collision, the front seatbacks should be always used in the upright position while the vehicle is running. If the front seatbacks are not used in the upright position in a collision, the risk of sliding under the lap belt and of the lap belt sliding up over the abdomen will increase, and both can result in serious injury or death.
- Do not put cushions or any other materials between occupants and seatbacks or seat cushions. If you do so, the risk of sliding under the lap belt and of the lap belt sliding up over the abdomen will increase, and both can result in serious injury or death.

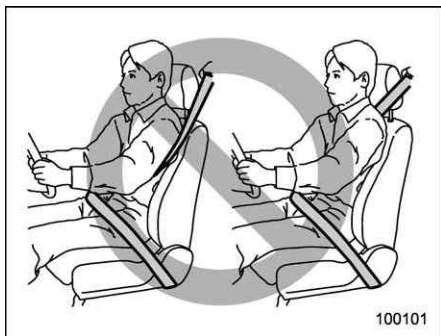

**WARNING**

Never place the shoulder belt under the arm or behind the back. If an accident occurs, this can increase the risk or severity of injury.

**CAUTION**

Metallic parts of the seatbelt can become very hot in a vehicle that has been closed up in sunny weather; they could burn an occupant. Do not touch such hot parts until they cool.

▼ **Front seatbelts**

1. Adjust the seat position according to the following procedure.

**Driver's seat:** Adjust the seatback to the upright position. Move the seat as far from the steering wheel as practical while still maintaining full vehicle control.

**Front passenger's seat:** Adjust the seatback to the upright position. Move the seat as far back as possible.

2. Sit well back in the seat.

3. Pick up the tongue plate and pull the belt out slowly. Do not let it get twisted.

- If the belt stops before reaching the buckle, return the belt slightly and pull it out more slowly.
- If the belt still cannot be unlocked, let the belt retract slightly after pulling it strongly, then pull it out slowly again.

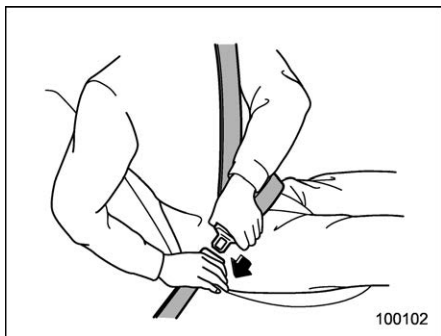

4. Insert the tongue plate into the buckle until you hear a click.

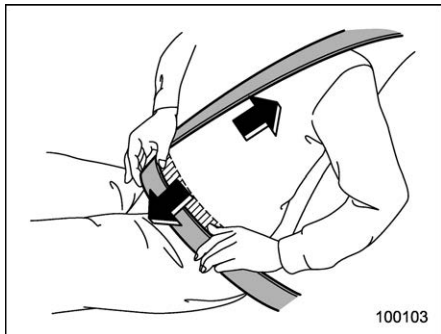

5. To tighten the lap part, pull up on the shoulder belt.

6. Place the lap belt as low as possible on the hips, not on the waist.

▽ Adjusting the front seat shoulder belt anchor height

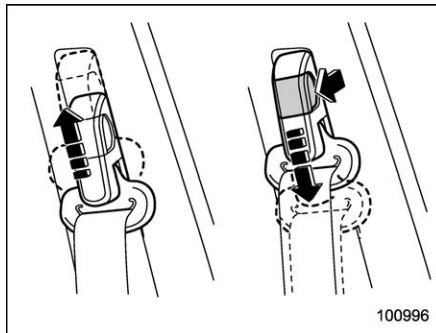

Adjust the shoulder belt anchor height to the position best suited for the driver/front passenger. Always adjust the anchor height so that the shoulder belt passes over the middle of the shoulder without touching the neck.

**To raise:**

Slide the anchor up.

**To lower:**

Pull the release knob and slide the anchor down.

Pull down on the anchor to make sure that it is locked in place.

**WARNING**

When wearing the seatbelts, make sure the shoulder portion of the webbing does not pass over your neck. If it does, adjust the seatbelt anchor to a lower position. Placing the shoulder belt over the neck may result in neck injury during sudden braking or in a collision.

▽ Unfastening the seatbelt

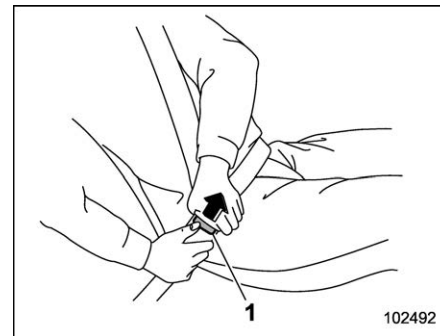

1) Button

1. Push the button on the buckle.
2. Allow the seatbelt to retract slowly to prevent it from getting tangled or twisted.

## 1-16 Seat, seatbelt and SRS airbags/Seatbelts

Before closing the door, make sure that the belts are retracted properly to avoid catching the belt webbing in the door.

### ▼ Rear seatbelts

1. Sit well back in the seat.
2. Pick up the tongue plate and pull the belt out slowly. Do not let it get twisted.
  - If the belt stops before reaching the buckle, return the belt slightly and pull it out more slowly.
  - If the belt still cannot be unlocked, let the belt retract slightly after pulling it strongly, then pull it out slowly again.

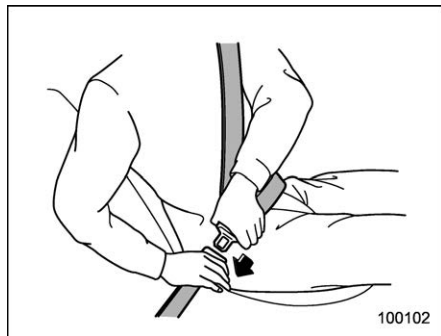

3. Insert the tongue plate into the buckle until you hear a click.

### NOTE

The center seatbelt buckle is marked as "CENTER".

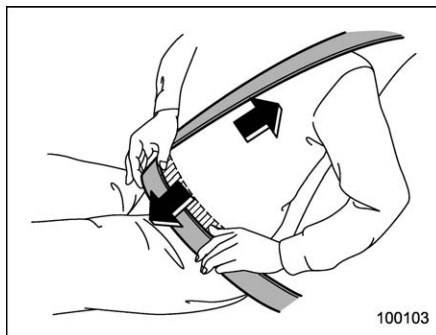

4. To tighten the lap part, pull up on the shoulder belt.
5. Place the lap belt as low as possible on the hips, not on the waist.

### ▽ Unfastening the seatbelt

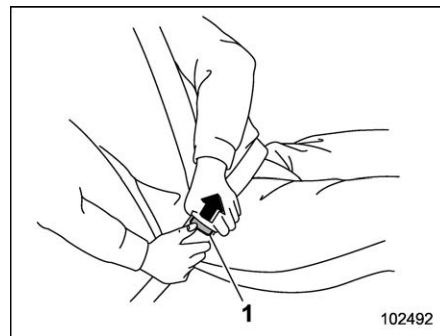

- 1) Button

1. Push the button on the buckle.
2. Retract the seatbelt slowly to prevent it from getting tangled or twisted.

Before closing the door, make sure that the belts are retracted properly to avoid catching the belt webbing in the door.

## ■ Seatbelt maintenance

To clean the seatbelts, use lukewarm water with mild soap. Do not use the seatbelts until they are dry. Never bleach or dye the belts because this could seriously affect their strength.

Inspect the seatbelts and attachments including the webbing and all hardware periodically for cracks, cuts, gashes, tears, damage, loose bolts or worn areas. Replace the seatbelts even if only minor damage is found.

### ⚠ CAUTION

- Keep the belts free of polishes, oils, chemicals and particularly battery acid.
- Never attempt to make modifications or changes that will prevent the seatbelt from operating properly.

## Front seatbelt pretensioners

The following seatbelts have a seatbelt pretensioner.

- Driver's seatbelt
- Front passenger's seatbelt

The seatbelt pretensioners are designed to be activated in the event of an accident involving a moderate to severe frontal and side collision and rollover accident.

### ⚠ WARNING

- To obtain maximum protection, the occupants should sit in an upright position with their seatbelts properly fastened. Refer to "Seatbelts" 1-12.
- Do not modify, remove or strike the front seatbelt retractor assemblies or surrounding area. This could result in accidental activation of the seatbelt pretensioners or could make the system inoperative, possibly resulting in serious injury. Seatbelt pretensioners have no user-serviceable parts. For required servicing of front seatbelt retractors equipped with seatbelt pretensioners, consult your SUBARU

dealer.

- When discarding front seatbelt retractor assemblies or scrapping the entire vehicle due to collision damage or for other reasons, consult your SUBARU dealer.

## NOTE

Seatbelt pretensioners are not designed to activate in minor impacts or in rear impacts.

## ■ Driver's seatbelt

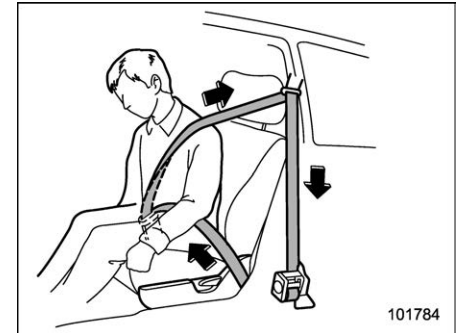

Front seatbelt pretensioner

The pretensioner sensor also serves as follows.

- SRS frontal airbag sensor
- Side impact sensor (front door impact sensor)
- Rollover sensor

If the sensor detects a certain predetermined amount of force during frontal or side collisions or rollover accidents, the front seatbelt is quickly drawn back in by the retractor to take up the slack so that the belt more effectively restrains the driver.

When a seatbelt pretensioner is activated, an operating noise will be heard and a small amount of smoke will be released. These occurrences are normal and not harmful. This smoke does not indicate a fire in the vehicle.

Once the seatbelt pretensioner has been activated, the seatbelt pretensioner remains locked. Consequently, the seatbelt cannot be pulled out and retracted and therefore must be replaced.

### ■ Front passenger's seatbelt

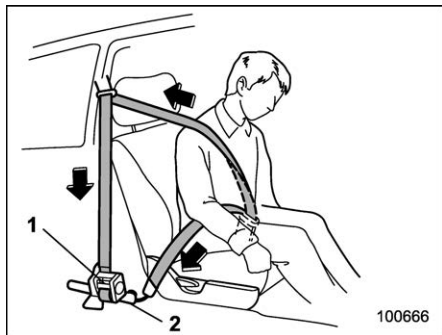

- 1) Seatbelt retractor assembly (shoulder belt pretensioner)
- 2) Lap belt pretensioner

The shoulder belt pretensioner is supplemented by a lap belt pretensioner, which is located at the base of the center pillar. Like the shoulder belt pretensioner, the lap belt pretensioner instantaneously pulls in the belt to eliminate slack if a certain level of frontal or side collision force is detected. As a result, the seatbelt restrains the front seat occupant more effectively.

## ■ Components that will operate with the seatbelt pretensioner(s) simultaneously

Cases		Frontal collision		Side collision	Rollover accident
		Offset frontal collision	Other frontal collision		
Seatbelt pretensioner for driver		○	○	○*2*3	○
Shoulder belt pretensioner for front passenger		○	○	○*3*4	
Lap belt pretensioner for front passenger		○	○	—	—
SRS frontal airbag	For driver	○	○		
	For front passenger*1	○	○		
SRS curtain airbag	Impacted side	○	—	○	○
	Non-impacted side	○	—	—	○
SRS side airbag	Impacted side	—	—	○*5	—
	Non-impacted side	—	—	—	—

○: Operate

—: Not operate

\*1: This does not operate if the occupant detections system deactivates airbag operation.

For details, refer to "Front passenger's SRS frontal airbag" 1-45.

\*2: This operates when both the satellite safing sensor and driver's side front door impact sensor sense an impact force.

\*3: These do not operate when a center pillar impact sensor detects a signal faster than the front door impact sensor, or both sensors detect signals simultaneously.

\*4: This operates when both the satellite safing sensor and the front passenger's side front door impact sensor sense an impact force.

\*5: This operates when both the satellite safing sensor and any of the center pillar impact sensors/front door impact sensors sense an impact force.

## ■ Safety tips

- Pretensioners are designed to function on a one-time-only basis. If a pretensioner is activated, have both front seatbelt retractor assemblies replaced only by an authorized SUBARU dealer. When replacing seatbelt retractor assemblies, use only genuine SUBARU parts.
- If either front seatbelt does not retract or cannot be pulled out due to a malfunction or activation of the pretensioner, contact your SUBARU dealer as soon as possible.
- If the front seatbelt retractor assembly or surrounding area has been damaged, contact your SUBARU dealer as soon as possible.
- When you sell your vehicle, we urge you to inform the buyer that the vehicle is equipped with seatbelt pretensioners. Also, notify the buyer of the contents of this section.

## ■ System monitors

A diagnostic system continually monitors the readiness of the seatbelt pretensioner with the ignition switch in the “ON” position. The seatbelt pretensioners share the control module with the SRS airbag system. Therefore, if any malfunction occurs in a seatbelt pretensioner, the SRS airbag system warning light will

illuminate. For details, refer to “SRS airbag system monitors” 1-64.

## ■ System servicing



### WARNING

- When discarding a seatbelt retractor assembly or scrapping the entire vehicle damaged by a collision, consult your SUBARU dealer.
- Tampering with or disconnecting the system’s wiring could result in accidental activation of the seatbelt pretensioner and/or SRS airbag or could make the system inoperative, which may result in serious injury. Do not use electrical test equipment on any circuit related to the seatbelt pretensioner and SRS airbag systems. For required servicing of the seatbelt pretensioner, consult your nearest SUBARU dealer.



### CAUTION

The sensors and SRS airbag control modules are located in the following locations.

- Front sub sensors: on both the right and left side at the front of the vehicle
- Front door impact sensors: on both front doors
- Satellite safing sensor: under the rear center seat
- Side airbag sensors: on both center pillars
- Curtain airbag sensors: on both rear wheel houses
- SRS airbag control module (including the impact sensors): under the center of the instrument panel

If you need service or repair in those areas or near the front seatbelt retractors, have the work performed by your authorized SUBARU dealer.

## NOTE

If the front or side part of the vehicle is damaged in an accident to the extent that the seatbelt pretensioner does not operate, contact your SUBARU dealer as soon as possible.



## ■ Precautions against vehicle modification

Always consult your SUBARU dealer if you want to install any accessory parts to your vehicle.

### CAUTION

Do not perform any of the following modifications. Such modifications can interfere with proper operation of the seatbelt pretensioners.

- Attachment of any equipment (bush bar, winches, snow plow, skid plate, etc.) other than genuine SUBARU accessory parts to the front end.
- Modification of the suspension system or front end structure.
- Installation of a tire of different size and construction from the tires specified on the vehicle placard attached to the driver's door pillar or specified for individual vehicle models in this Owner's Manual.

## Child restraint systems

### ■ Safety precautions



Infants and small children should always be placed in an infant or child restraint system in the rear seat while riding in the vehicle. You should use an infant or child restraint system that meets Federal Motor Vehicle Safety Standards or Canada Motor Vehicle Safety Standards, is compatible with your vehicle and is appropriate for the child's age and size. All child restraint systems are designed to be secured in vehicle seats by lap belts or the lap belt portion of a lap/shoulder belt (except those described in "Installation of child restraint systems by use of lower and tether anchorages (LATCH)" ¶ 1-31).

Children could be endangered in an

accident if their child restraint systems are not properly secured in the vehicle. When installing the child restraint system, carefully follow the manufacturer's instructions.

According to accident statistics, children are safer when properly restrained in the rear seating positions than in the front seating positions.

All U.S. states and Canadian provinces require that infants and small children be restrained in an approved child restraint system at all times while the vehicle is moving.

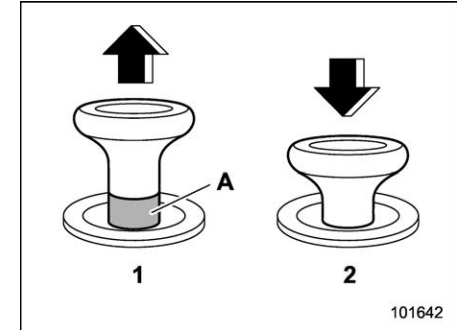

#### Lock release knob

- 1) Unlocked
  - 2) Locked
- A) Unlocking marker in red

**⚠ WARNING**

- Before installing a child restraint system, be sure to confirm that the seatback is securely locked into place. Otherwise, in an accident, serious injury or death could result.
- Do not leave children in the car unattended. High interior temperatures may cause heat stroke and dehydration that result in serious injury or death.



**⚠ WARNING**

Never let a passenger hold a child on his or her lap or in his or her arms

while the vehicle is moving. The passenger cannot protect the child from injury in a collision, because the child will be caught between the passenger and objects inside the vehicle.

Additionally, holding a child in your lap or arms in the front seat exposes that child to another serious danger. Since the SRS airbag deploys with considerable speed and force, the child could be injured or even killed.

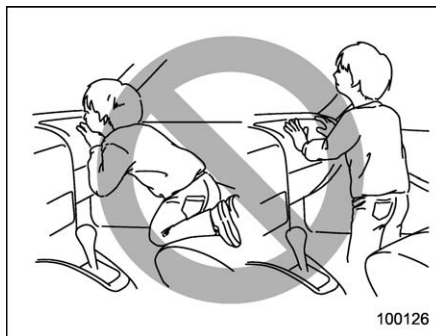

**⚠ WARNING**

Children should be properly restrained at all times. Never allow a child to stand up, or to kneel on any

seat. Unrestrained children will be thrown forward during sudden stop or in an accident and can be injured seriously.

Additionally, children standing up or kneeling on or in front of the front seat are exposed another serious danger. Since the SRS airbag deploys with considerable speed and force, the child could be injured or even killed.

**■ Safety tips for installing child restraint systems**

**⚠ WARNING**

- Do not use a seat belt extender. If a seat belt extender is used when installing a child restraint system, the seat belt will not securely hold the child restraint system. Use of a seat belt extender could cause death or serious injury to children or other passengers in sudden braking, swerving, or accidents.
- Attach the child restraint system to the anchors properly. When using the LATCH anchors, be sure that there are no foreign

objects around the anchors. Also, the seat belts should not be caught behind the child restraint system. Make sure the child restraint system is securely attached. Otherwise it may cause death or serious injury to children or other passengers in sudden braking, swerving, or accidents.

- Child restraint systems and seatbelts can become hot in a vehicle that has been closed up in sunny weather; they could burn a small child. Check the child restraint system before you place a child in it.
- Do not leave an unsecured child restraint system in your vehicle. Unsecured child restraint systems can be thrown around inside of the vehicle in a sudden stop, turn or accident; they can strike and injure vehicle occupants as well as result in serious injuries or death to the child.

**⚠ CAUTION**

When you install a child restraint system, follow the manufacturer's

instructions supplied with it. After installing the child restraint system, check to ensure that it is held securely in position. If it is not held tight and secure, the danger of your child suffering personal injury in the event of an accident may be increased.

**■ Where to place a child restraint system**

The following are SUBARU's recommendations on where to place a child restraint system in your vehicle.

**⚠ WARNING**

- Several types of child restraint systems may conceal the buckle of the neighboring seat. If the occupant of the neighboring seat cannot correctly fasten the seatbelt, that person must move to a different seat. If the seatbelt cannot be correctly fastened, there is the risk of serious injury or death in the event of sudden braking or a collision.
- If the child restraint system cannot be correctly installed because it contacts the driver's

seat, move the child restraint system to a different seat. If it cannot be installed in a different seat (other than the driver's seat), adjust the front seat so that contact does not occur.

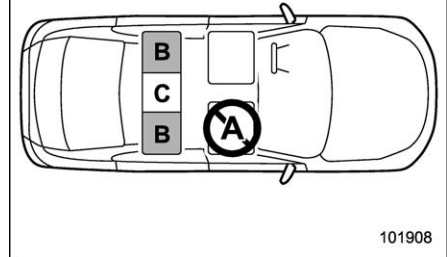

**A: Front passenger's seat**

You should not install a child restraint system (including a booster seat) due to the hazard to children posed by the passenger's airbag.

**B: Rear seat, window-side seating positions**

Recommended positions for all types of child restraint systems.

In these positions, the following equipment is provided for installing a child restraint

system.

- Automatic Locking Retractor/Emergency Locking Retractor (ALR/ELR) seatbelts
- Lower anchorages (bars)
- Upper anchorages (tether anchorages)

Some types of child restraint systems might not be able to be secured firmly due to projection of the seat cushion.

In this seating position, you should use only a child restraint system that has a bottom base that fits snugly against the contours of the seat cushion and can be securely retained using the seatbelt.

### **C: Rear seat, center seating position**

The ALR/ELR seatbelt and an upper anchorage (tether anchorage) are provided in this position.

Some types of child restraint systems might not be able to be secured firmly due to projection of the seat cushion.

In this seating position, you should use only a child restraint system that has a bottom base that fits snugly against the contours of the seat cushion and can be securely retained using the seatbelt.

Lower anchorages (bars) for window-side seating positions may be used for a seat in the center seating position if a child restraint system manufacturer's instruc-

tions permit and specify using anchors as far apart as those in this vehicle.

If a child restraint system is not correctly fixed in place (for example, if a child restraint system can be moved more than 1 inch (2.5 cm) from side to side), you should install the child restraint system in a rear seat, window-side seating position.

### **WARNING**

- **Even with advanced airbags, children can be seriously injured by the airbag. Place children in the rear seat properly restrained at all times. The SRS airbag deploys with considerable speed and force and can injure or even kill children, especially if they are not restrained or improperly restrained. Because children are lighter and weaker than adults, their risk of being injured from deployment is greater.**

**For that reason, be sure to secure ALL types of child restraint system (including forward facing child restraint systems) in the REAR seats at all times. You should choose a restraint device which is appropriate for the child's age, height and weight.**

**According to accident statistics, children are safer when properly restrained in the rear seating positions than in the front seating positions.**

- **Do not use lower anchorages (bars) for a seat in the center seating position unless a child restraint system manufacturer's instructions permit and specify using anchors spaced as far apart as those in this vehicle.**
- **Do not connect two or more lower hooks onto the same anchorage (bar).**

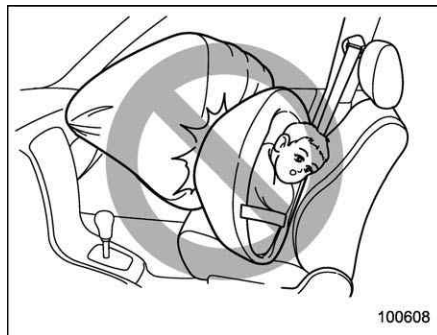

100608

**▲ WARNING**

- **SINCE YOUR VEHICLE IS EQUIPPED WITH A PASSENGER'S SRS AIRBAG, NEVER INSTALL A CHILD RESTRAINT SYSTEM IN THE FRONT PASSENGER'S SEAT. DOING SO RISKS SERIOUS INJURY OR DEATH TO THE CHILD BY PLACING THE CHILD'S HEAD TOO CLOSE TO THE SRS AIRBAG.**
- **Do not allow children to lean their heads or other body parts against the door of the vehicle, or the areas around the door. Deployment of the SRS side and curtain airbags could impact the child resulting in death or serious injury.**
- **To secure the child restraint system, be sure to comply with all installation instructions provided by the child restraint manufacturer. Not doing so could result in death or serious injury to children in a sudden stop or accident.**

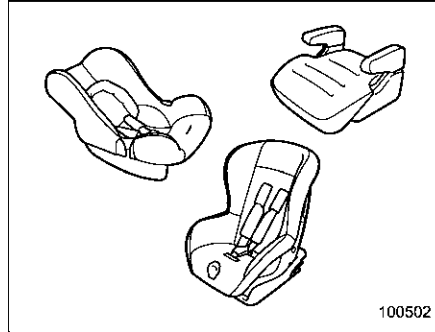
**■ Choosing a child restraint system**

Choose a child restraint system that is appropriate for the child's age and size (weight and height) in order to provide the child with proper protection. The child restraint system should meet all applicable requirements of Federal Motor Vehicle Safety Standards for the United States or of Canada Motor Vehicle Safety Standards for Canada. It can be identified by looking for the label on the child restraint system or the manufacturer's statement of compliance in the document attached to the system.

Also it is important for you to make sure that the child restraint system is compatible with the vehicle in which it will be used.

**■ Installing child restraint systems with ALR/ELR seatbelt****▲ CAUTION**

- **When you install a child restraint system, follow the manufacturer's instructions supplied with it. After installing the child restraint system, check to ensure that it is held securely in position. If it is not held tight and secure, the danger of your child suffering personal injury in the event of an accident may be increased.**
- **When installing a child restraint system in the rear center seating position, set both seatbacks to the original position. Otherwise, the child restraint system cannot be securely restrained, which may result in death or serious injuries in the event of sudden stop, sudden steering maneuver or an accident.**

▼ Installing a rearward facing child restraint system

**WARNING**

- NEVER INSTALL A CHILD RESTRAINT SYSTEM IN THE FRONT PASSENGER'S SEAT. DOING SO RISKS SERIOUS INJURY OR DEATH TO THE CHILD BY PLACING THE CHILD'S HEAD TOO CLOSE TO THE SRS AIRBAG.
- Before installing a child restraint system, be sure to confirm that the seatback is securely locked into place.

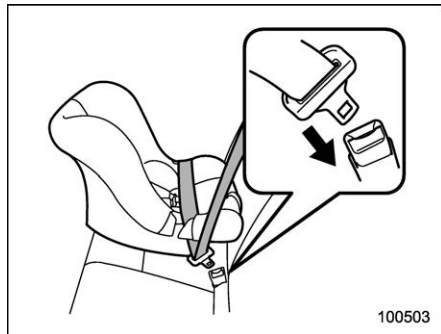

1. Move the seatback back and forth to confirm that it is securely locked into place.
  - Check that the red colored unlocking marker which is attached to the bottom of the lock release knob is invisible. For details, refer to “Folding down the rear seatback” 1-9.
2. Place the child restraint system in the rear seating position.

**WARNING**

**When you intend to install a child restraint system in the rear center seating position, if the child restraint system does not fit snugly against the contours of the rear center seat cushion, install the child restraint system in the window-side seating position to be safe. For details, refer to “Where to place a child restraint system” 1-23.**

3. Run the lap and shoulder belt through or around the child restraint system following the instructions provided by its manufacturer.
4. Insert the tongue plate into the buckle until you hear a click.

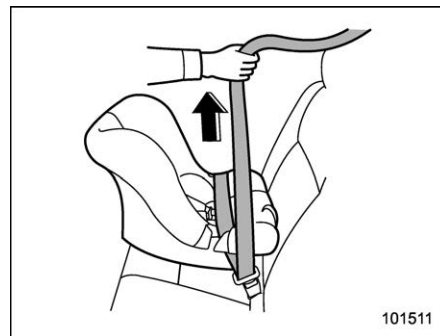

5. Take up the slack in the lap belt.
6. If using the seatbelt in the ALR mode is recommended by the manufacturer's instructions supplied with the child restraint system, perform the following procedure.
  - (1) Pull out the seatbelt fully from the retractor to change the retractor over from the Emergency Locking Retractor (ELR) to the Automatic Locking Retractor (ALR) mode.
  - (2) Allow the belt to rewind into the retractor. As the belt is rewinding, clicks will be heard which indicate the retractor functions as ALR.

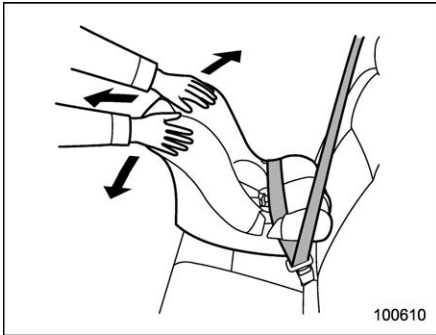

7. Push and pull the child restraint system forward and from side to side to check if it is firmly secured. Sometimes a child restraint system can be more firmly secured by pushing it down into the seat cushion and then tightening the seatbelt.

8. If the seatbelt has been set to the ALR mode in step 6, pull at the shoulder portion of the belt to confirm that it cannot be pulled out (ALR properly functioning).

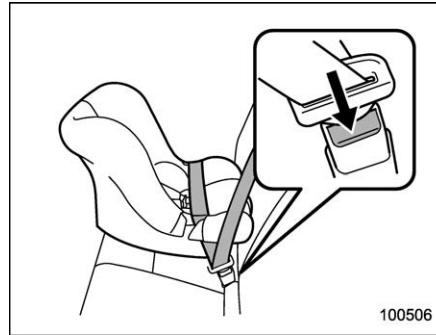

9. To remove the child restraint system, press the release button on the seatbelt buckle and allow the belt to retract completely. The belt will return to the ELR mode.

### NOTE

**When the child restraint system is no longer in use, remove it and restore the ELR function of the retractor. That function is restored by allowing the seatbelt to retract fully.**

### ▼ Installing forward facing child restraint system

#### WARNING

- **NEVER INSTALL A CHILD RESTRAINT SYSTEM IN THE FRONT PASSENGER'S SEAT. DOING SO RISKS SERIOUS INJURY OR DEATH TO THE CHILD BY PLACING THE CHILD'S HEAD TOO CLOSE TO THE SRS AIRBAG.**
- **Before installing a child restraint system, be sure to confirm that the seatback is securely locked into place. Otherwise, in an accident, serious injury or death could result.**

1. Move the seatback back and forth to confirm that it is securely locked into place.

- Check that the red colored unlocking marker which is attached to the bottom of the lock release knob is invisible. For details, refer to "Folding down the rear seatback" 1-9.

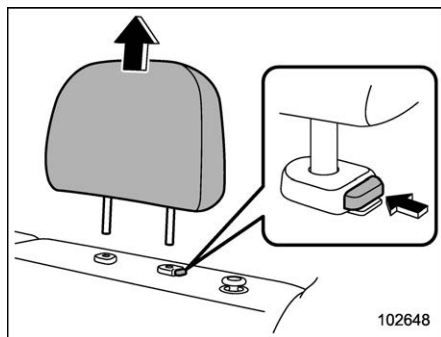

2. Remove the head restraint of the rear seating position where the child restraint system is to be installed. For details, refer to "Head restraint adjustment" 1-8.
3. Store the removed head restraint in the trunk.

**CAUTION**

**Do not place the head restraint in the passenger compartment to prevent it from being thrown around in the passenger compartment in a sudden stop or a sharp turn.**

4. Place the child restraint system in the rear seating position.

**WARNING**

**When you intend to install a child restraint system in the rear center seating position, if the child restraint system does not fit snugly against the contours of the rear center seat cushion, install the child restraint system in the window-side seating position to be safe. For details, refer to "Where to place a child restraint system" 1-23.**

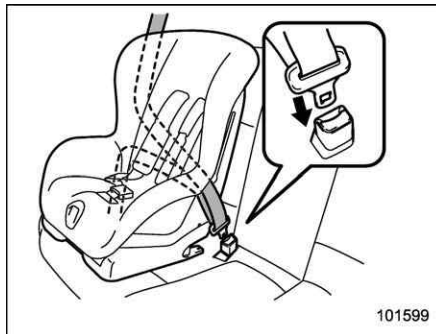

5. Run the lap and shoulder belt through or around the child restraint system following the instructions provided by its manufacturer.
6. Insert the tongue plate into the buckle until you hear a click.

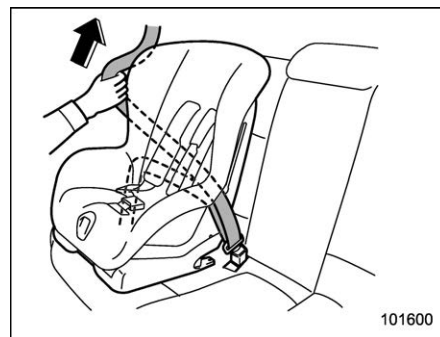

7. Take up the slack in the lap belt.
8. Pull out the seatbelt fully from the retractor to change the retractor over from the Emergency Locking Retractor (ELR) to the Automatic Locking Retractor (ALR) function. Then allow the belt to rewind into the retractor. As the belt is rewinding, clicks will be heard which indicate the retractor functions as ALR.



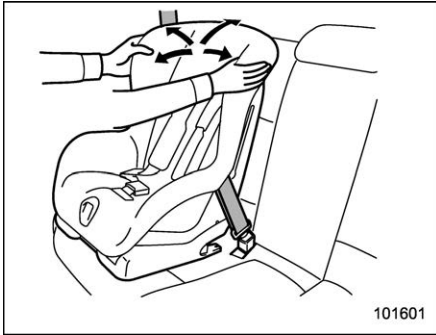

9. Before having a child sit in the child restraint system, try to move it back and forth and right and left to check if it is firmly secured. Sometimes a child restraint system can be more firmly secured by pushing it down into the seat cushion and then tightening the seatbelt.

10. Pull at the shoulder portion of the belt to confirm that it cannot be pulled out (ALR properly functioning).

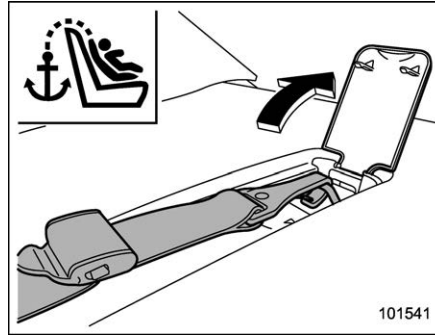

11. Latch the top tether hook onto the tether anchorage that is located behind the rear seat and tighten the top tether firmly. For additional instructions, refer to “Top tether anchorages” 1-34.

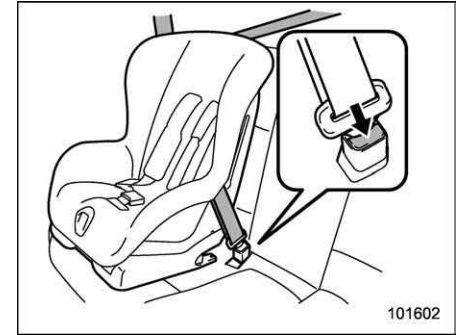

12. To remove the child restraint system, press the release button on the seatbelt buckle and allow the belt to retract completely. The belt will return to the ELR mode.

### NOTE

**When the child restraint system is no longer in use, remove it and restore the ELR function of the retractor. That function is restored by allowing the seatbelt to retract fully.**

## ■ Installing a booster seat or booster cushion



**Booster seat**

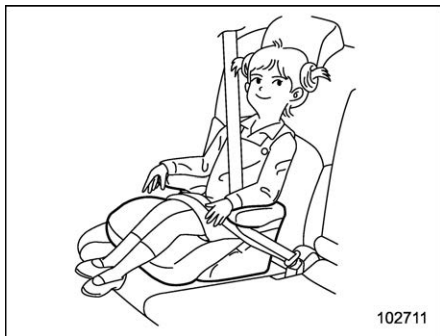

**Booster cushion**

1. Adjust the head restraint as follows.

For booster seat:

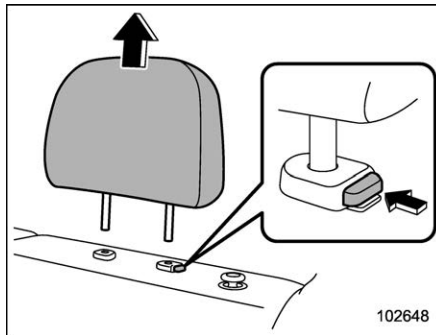

- (1) Remove the head restraint from the rear seating position where the child restraint system is to be installed.
- (2) Store the removed head restraint in the trunk.

### CAUTION

**Do not place the head restraint in the passenger compartment to prevent it from being thrown around in the passenger compartment in a sudden stop or a sharp turn.**

For booster cushion:

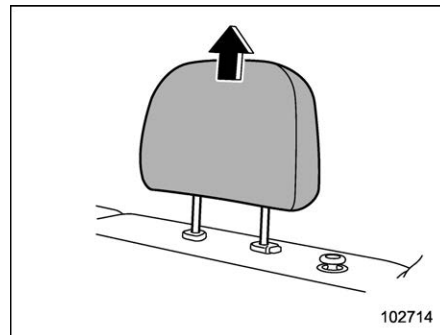

- (1) Raise the head restraint to the extended position. Do not remove the head restraint.



2. Place the booster seat/cushion in the

rear seating position and sit the child on it. The child should sit well back on the booster seat/cushion.

3. Run the lap and shoulder belt through or around the booster seat/cushion and the child following the instructions provided by its manufacturer. For booster seat/cushion with a belt guide, use the seatbelt through the belt guide.

4. Insert the tongue plate into the buckle until you hear a click. Take care not to twist the seatbelt.

Make sure the shoulder belt is positioned across the center of child's shoulder and that the lap belt is positioned as low as possible on the child's hips.

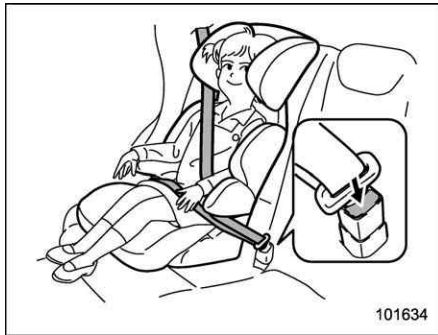

5. To remove the booster seat/cushion, press the release button on the seatbelt buckle and allow the belt to retract.

### ⚠ WARNING

- **Never use a belt that is twisted or reversed. In an accident, this can increase the risk or severity of injury to the child.**
- **Never place the shoulder belt under the child's arm or behind the child's back. If an accident occurs, this can increase the risk or severity of injury to the child.**
- **The seatbelt should fit snugly in order to provide full restraint. Loose fitting belts are not as effective in preventing or reducing injury.**
- **Place the lap belt as low as possible on the child's hips. A high-positioned lap belt will increase the risk of sliding under the lap belt and of the lap belt sliding up over the abdomen, and both can result in serious internal injury or death.**
- **Make sure the shoulder belt is positioned across the center of child's shoulder. Placing the shoulder belt over the neck may result in neck injury during sudden braking or in a collision.**

### ■ Installation of child restraint systems by use of lower and tether anchorages (LATCH)

#### ▼ Lower and tether anchorages

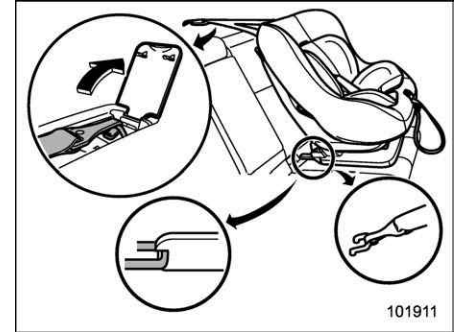

Some types of child restraint systems can be installed on the rear seat of your vehicle without use of the seatbelts. Such child restraint systems are secured to the designated anchorages provided on the vehicle body. The lower and tether anchorages are sometimes referred to as the LATCH system (Lower Anchors and Tethers for Children).



Anchor. Tether.  
**LATCH**  
The next generation  
of child safety.

101210

Your vehicle is equipped with four lower anchorages (bars) and three upper anchorages (tether anchorages) for accommodating such child restraint systems.

### ▽ Lower anchorages

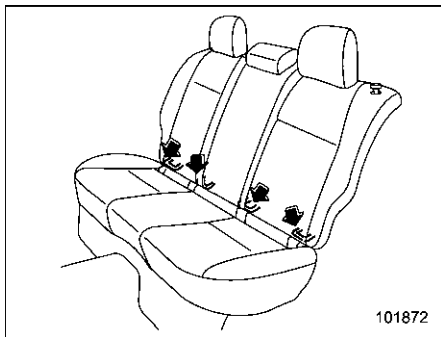

101872

### WARNING

**Do not connect two or more lower hooks onto the same anchorage (bar).**

Two lower anchorages (bars) are provided for installing a child restraint system on the rear seat window-side seating positions. Lower anchorages (bars) for window-side seating positions may be used for a seat in the center seating position if a child restraint system manufacturer's instructions permit and specify using anchors as far apart as those in this vehicle. Each lower anchorage is located where the seat cushion meets the seatback.

### ▽ Tether anchorages

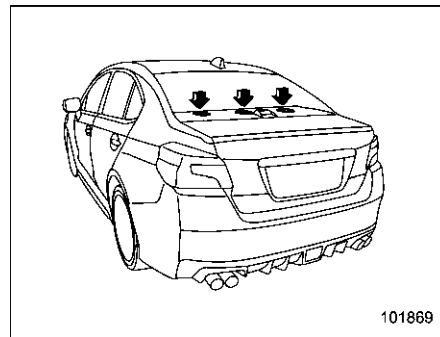

101869

The tether anchorages (upper anchorages) are provided at the locations shown in the above illustration. For details, refer to "Top tether anchorages" 1-34.

### ▽ To install a child restraint system using lower and tether anchorages

To install a child restraint system using lower and tether anchorages, perform the following procedure.

### WARNING

**Before installing a child restraint system, be sure to confirm that the seatback is securely locked into place. Otherwise, in an accident,**

**serious injury or death could result.**

1. Move the seatback back and forth to confirm that it is securely locked into place.
  - Check that the red colored unlocking marker which is attached to the bottom of the lock release knob is invisible. For details, refer to “Folding down the rear seatback” 1-9.

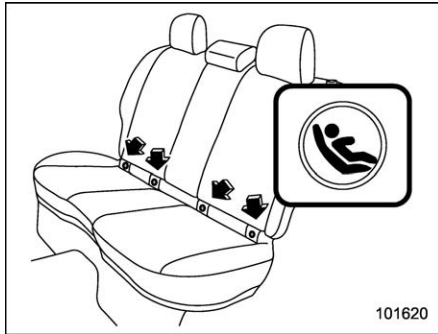

2. You will find marks “L” at the bottom of the rear seat seatbacks. These marks indicate the positions of the lower anchorages (bars).

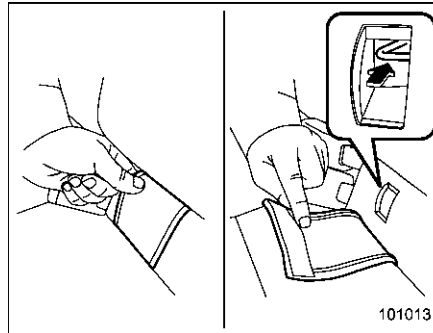

Remove the covers and locate the lower anchorages (bars).

If it is hard to install the child restraint system because the anchorage cover returns to the original position, press the anchorage cover to the seat cushion until it is flat.

3. Remove the rear seat head restraint. For details, refer to “Head restraint adjustment” 1-8.
4. Store the removed head restraint in the trunk.

**CAUTION**

**Do not place the head restraint in the passenger compartment to prevent it from being thrown around in the passenger compartment in a sud-**

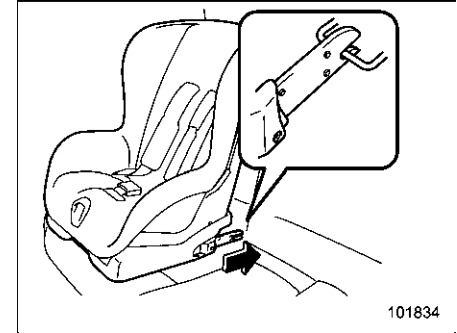
**den stop or a sharp turn.**

5. While following the instructions supplied by the child restraint system manufacturer, connect the lower hooks onto the lower anchorages located at “L” marks on the bottom of the rear seatback. When the hooks are connected, make sure the adjacent seatbelts are not caught.

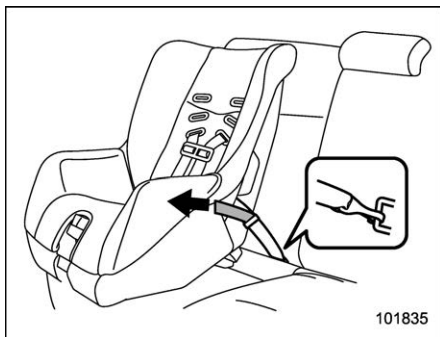

6. If your child restraint system is a flexible attachment type (which uses tether belts), push the child restraint system into the seat cushion and pull both left and right lower tether belts up to secure the child restraint system by taking up the slack in the belt.

7. Latch the top tether hook onto the tether anchorage that is located on the rear shelf and tighten the top tether firmly. For additional instructions, refer to “Top tether anchorages” 1-34.

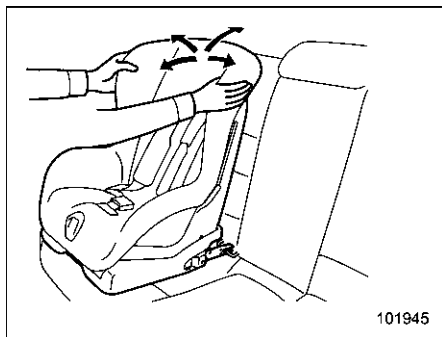

8. Before seating a child in the child restraint system, try to move it back and forth and right and left to verify that it is held securely in position.

9. To remove the child restraint system, follow the reverse procedures of installation.

If you have any question concerning this type of child restraint system, ask your SUBARU dealer.

## ■ Top tether anchorages

Your vehicle is equipped with three top tether anchorages so that a child restraint system having a top tether can be installed in the rear seat. When installing a child restraint system using top tether, proceed as follows, while observing the instructions by the child restraint system manufacturer.

Since a top tether can provide additional stability by offering another connection between a child restraint system and the vehicle, we recommend that you use a top tether whenever one is required or available.

▼ Anchorage location

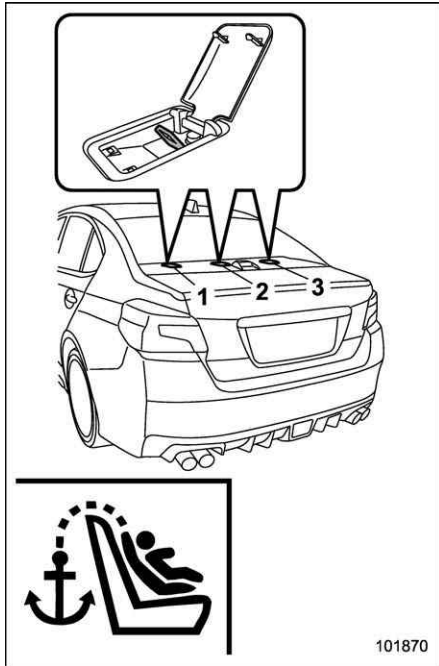

- 1) For left seat
- 2) For center seat
- 3) For right seat

These upper anchorages are installed on the rear shelf behind the rear seat.

▼ To hook the top tether

**⚠ CAUTION**

Remove the head restraint when mounting a child restraint system. Otherwise, it might be possible that the top tether cannot be fastened tightly.

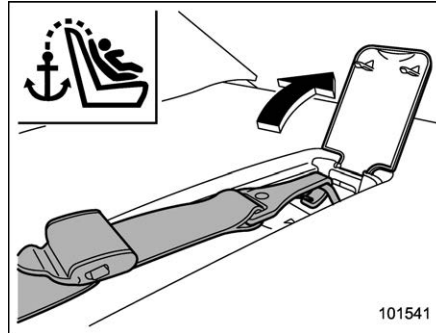

1. Open the cover and attach the top tether hook to the appropriate upper anchorage.
2. Tighten the top tether securely.

Please contact your SUBARU dealer if you have any question regarding the installation of a child restraint system.

## SRS airbag (Supplemental Restraint System airbag)

Supplemental Restraint System (SRS) name is used because the airbag system supplements the vehicle's seatbelts.

This vehicle is equipped with a supplemental restraint system which consists of the following airbags:

- Driver's and front passenger's **frontal airbags**
- Driver's and front passenger's **side airbags**
- **Curtain airbags** (for driver, front passenger, and window-side rear passengers)
- **Knee airbag** for driver

**These SRS airbags are designed only as a supplement to the primary protection provided by the seatbelt.**

The system also controls front seatbelt pretensioners. For operation instructions and precautions concerning the seatbelt pretensioner, refer to "Front seatbelt pretensioners" Ⓞ 1-17.

## ■ General precautions regarding SRS airbag system

### ⚠ WARNING

- To obtain maximum protection in the event of an accident, the driver and all passengers must always wear seatbelts when in the vehicle. The SRS airbag is designed only to be a supplement to the primary protection provided by the seatbelt. It does not eliminate the need to fasten seatbelts. In combination with the seatbelts, it offers the best protection in case of a serious accident.

Not wearing a seatbelt increases the chance of severe injury or death in a crash even when the vehicle has the SRS airbag system.

For instructions and precautions concerning the seatbelt system, refer to "Seatbelts" 1-12.

- The SRS side airbags and SRS curtain airbags are designed only to be a supplement to the primary protection provided by the seatbelt. They do not eliminate the need to fasten seatbelts. It is also

important to wear a seatbelt to help avoid injuries that can result when an occupant is not seated in a proper upright position.

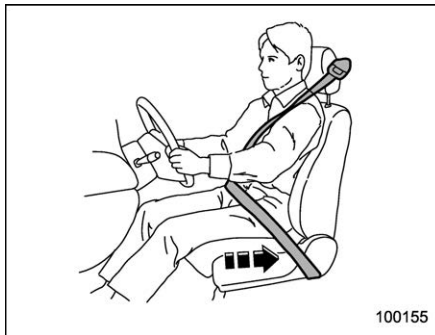

### ⚠ WARNING

The SRS airbags deploy with considerable speed and force. Occupants who are not seated in proper upright position when the SRS airbag deploys could suffer serious injury. Because the SRS airbag needs enough space for deployment, the driver should always sit upright and back in the seat as far from the steering wheel as practical while still maintaining full vehicle control, and the front passenger

should move the seat as far back as possible and sit upright and well back in the seat.



### ⚠ WARNING

- Do not sit or lean close to either front door. The SRS side airbags are stored in both front seat seatbacks next to the door, and they provide protection by deploying rapidly in the event of a side impact collision. However, the force of SRS side airbag deployment can injure an occupant whose body is too close to an SRS airbag.



- Since your vehicle is equipped with SRS curtain airbags, do not sit or lean close to the front or rear door on either side. Do not put body parts out of the window. The SRS curtain airbags on both sides of the cabin are stored in the roof side (between the front pillar and a point behind the rear quarter glass), and they provide protection by deploying rapidly in the event of a side impact, rollover or an offset frontal collision. However, the force of its deployment can injure an occupant whose body is too close to an SRS airbag.

- Do not sit or lean unnecessarily close to the SRS airbag. Because the SRS airbag deploys with considerable speed and force to protect in high speed collisions, the force of an airbag can injure an occupant whose body is too close to SRS airbag.

It is also important to wear seatbelts to help avoid injuries that can result when the SRS airbag contacts an occupant not in their proper position.

Even when properly positioned, there remains a possibility that

an occupant may suffer minor injury, such as abrasions and bruises to the face or arms, because of the SRS airbag deployment force.



### ⚠ WARNING

- Keep arms away from either front door or its internal trim. They could be injured in the event of SRS side airbag deployment.
- Do not place any objects over or near the SRS airbag cover or between you and the SRS airbag. If the SRS airbag deploys, these objects could interfere with its proper operation and could be

propelled inside the vehicle, causing injury.

### ⚠ CAUTION

- When the SRS airbag deploys, some smoke will be released. This smoke could cause breathing problems for people with a history of asthma or other breathing trouble. If you or your passengers have breathing problems after SRS airbag deploys, get fresh air promptly.
- A deploying SRS airbag releases hot gas. Occupants could get burned if they come into direct contact with the hot gas.

### NOTE

- When you sell your vehicle, we urge you to inform the buyer that the vehicle is equipped with SRS airbags. Also, notify the buyer of the applicable section of this Owner's Manual.

- If the SRS airbag deploys, fuel supply will be cut off to reduce the risk of fire caused by leaking fuel. For details about restarting of the engine, refer to “If your vehicle is involved in an accident” 9-20.

### ■ General precautions regarding SRS airbag system for accessories and any objects

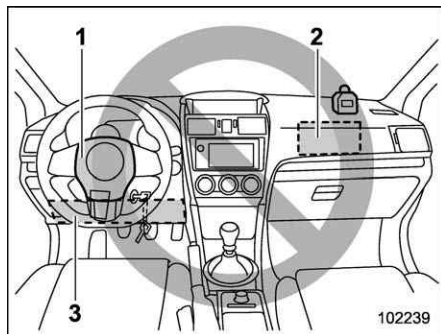

**Do not put any objects over/under the following parts.**

- 1) Over the steering wheel pad
- 2) Over the dashboard
- 3) Under the driver's side of the instrument panel

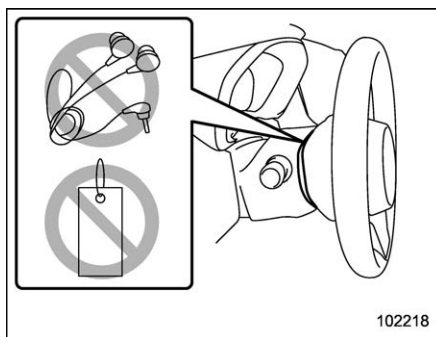

### **▲ WARNING**

- Do not put any objects (including straps or cords) over the steering wheel pad, column cover, or dashboard.
  - These objects could be entangled with the steering wheel, preventing the SRS frontal airbag, etc. from operating properly.
  - If the SRS frontal airbag deploys, these objects could be propelled inside the vehicle, causing injury.
- Do not put any objects under the driver's side of the instrument panel. If the SRS knee airbag

deploys, those objects could interfere with its proper operation and could be propelled inside the vehicle, causing injury.

- The key must not be attached to heavy, sharp or hard accessories, or another key. If the SRS knee airbag deploys, those objects could interfere with its proper operation and could be propelled inside the vehicle and cause injury.

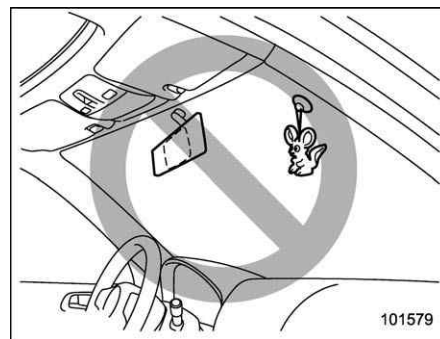

**⚠ WARNING**

Do not attach accessories to the windshield, or fit an extra-wide mirror over the inside rear view mirror. If the SRS airbag deploys, those objects could become projectiles that could seriously injure vehicle occupants.

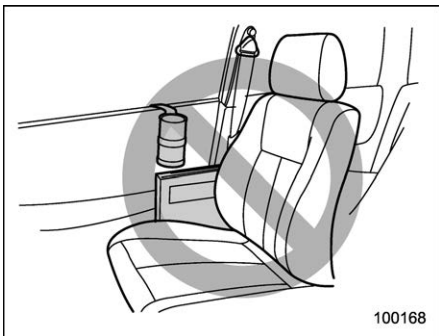

100168

**⚠ WARNING**

- Do not attach accessories to the door trim or near either SRS side airbags and do not place objects near the SRS side airbags. In the event of SRS side airbag deployment, they could be propelled dangerously toward the vehicle's occupants and cause injuries.
- Do not attach a hands-free microphone or any other accessory to a front pillar, a center pillar, a rear pillar, the windshield, a side window, an assist grip, or any other cabin surface that would be near a deploying SRS curtain airbag. A hands-free microphone or other accessory in such a location could be propelled through the cabin with great force by the curtain airbag, or it could prevent correct deployment of the curtain airbag. In either case, the result could be serious injuries.

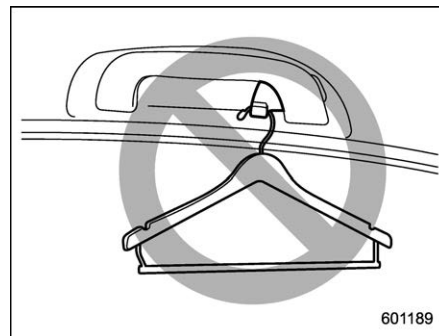

601189

**⚠ WARNING**

Do not hang coat hangers or other hard or pointed objects on the coat hooks. If such items were hanging on the coat hooks during deployment of the SRS curtain airbags, they could cause serious injuries by coming off the coat hooks and being thrown through the cabin or by preventing deployment of the curtain airbags.

Before hanging clothing on the coat hooks, make sure there are no sharp objects in the pockets. Hang clothing directly on the coat hooks without using hangers.

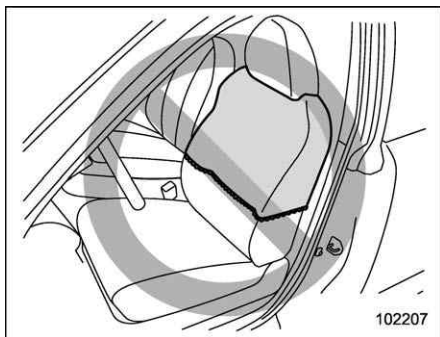

**⚠ WARNING**

- Do not put any kind of clothes or other objects over either front seatback and do not attach labels or stickers to the front seat surface on or near the SRS side airbag. They could prevent proper deployment of the SRS side airbag, reducing protection available to the front seat's occupant.
- Do not install a seat cover unless it is a genuine SUBARU seat cover exclusively designed for use with the SRS airbag. Even when using a genuine SUBARU seat cover, the SRS side airbag system may not function nor-

mally if the seat cover is not installed correctly.

■ **General precautions regarding SRS airbag system for children**



**⚠ WARNING**

Place children in the rear seat properly restrained at all times. The SRS airbag deploys with considerable speed and force and can injure or even kill children, especially if they are not restrained or improperly restrained. Because children are lighter and weaker than adults, their risk of being injured from deploy-

ment is greater.

For that reason, we strongly recommend that ALL children (including those in child seats and those that have outgrown child restraint devices) sit in the REAR seat properly restrained at all times in a child restraint device or in a seatbelt, whichever is appropriate for the child's age, height and weight.

Secure ALL types of child restraint devices (including forward facing child seats) in the REAR seats at all times.

According to accident statistics, children are safer when properly restrained in the rear seating positions than in the front seating positions.

For instructions and precautions concerning the child restraint system, refer to "Child restraint systems" 1-21.

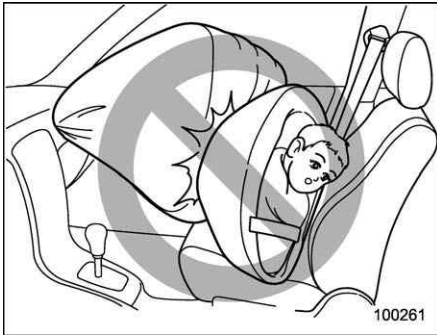

**⚠ WARNING**

**NEVER INSTALL A CHILD SEAT IN THE FRONT SEAT. DOING SO RISKS SERIOUS INJURY OR DEATH TO THE CHILD BY PLACING THE CHILD'S HEAD TOO CLOSE TO THE SRS AIRBAG.**

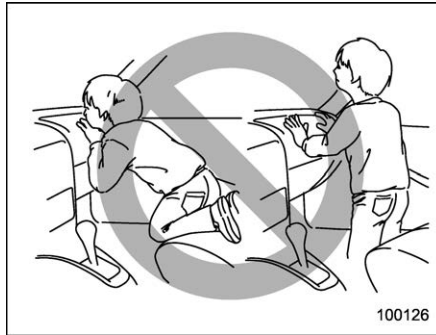

**⚠ WARNING**

**Observe the following instructions.**

- **Never allow a child to stand up or kneel on the front passenger's**

**seat.**

- **Never hold a child on your lap or in your arms.**

**Since the SRS airbag deploys with considerable force, it can injure or even kill a child.**

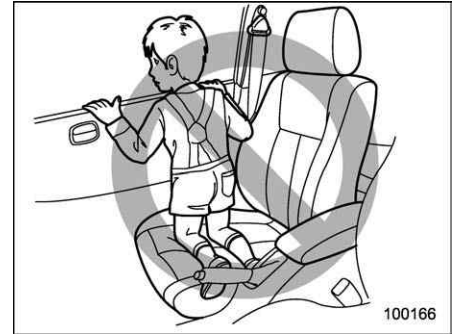

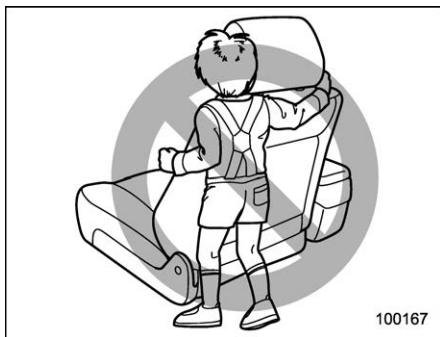

**⚠ WARNING**

- Never allow a child to do the following.
  - Kneel on any passenger's seat facing the side window.
  - Wrap his/her arms around the front seat seatback.
  - Put his/her head, arms or other parts of the body out of the window.

In the event of an accident, the force of SRS side airbag and/or SRS curtain airbag deployment could injure the child seriously because his/her head, arms or other parts of the body are too close to the SRS side airbag and/

or SRS curtain airbag.

- Since your vehicle is also equipped with a front passenger's SRS frontal airbag, children should be placed in the rear seat anyway and should be properly restrained at all times.

■ **Components**

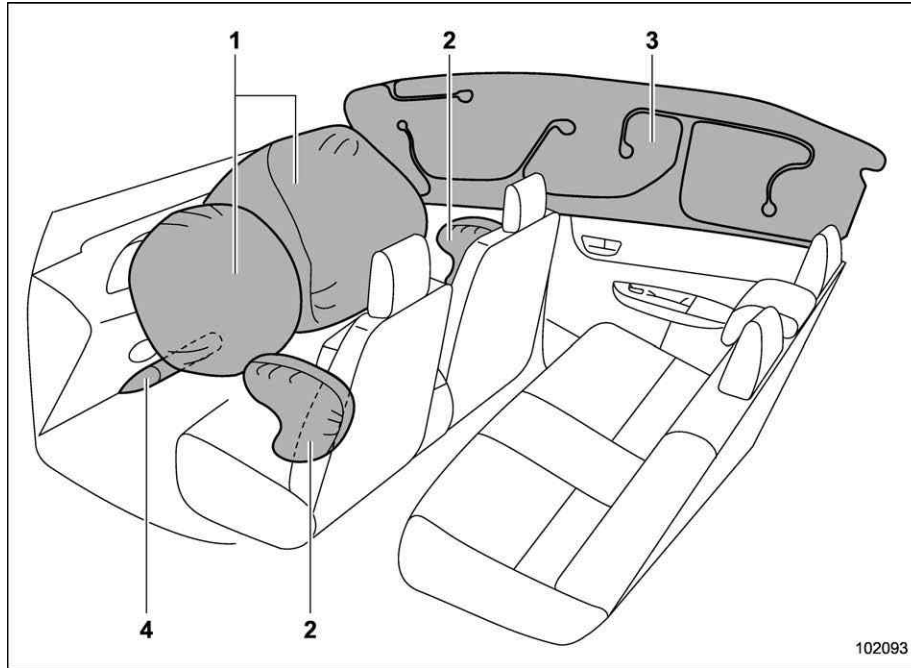

The SRS airbags are stowed in the following locations.

**Driver's SRS frontal airbag:** in the center portion of the steering wheel

**Front passenger's SRS frontal airbag:** near the top of the dashboard under an "SRS AIRBAG" mark

**SRS side airbag:** in the door side of each front seat seatback which bears an "SRS AIRBAG" label

**SRS curtain airbag:** in the roof side (between the front pillar and a point behind the rear quarter glass)

An "SRS AIRBAG" mark is located at the top of each center pillar and rear pillar.

**SRS knee airbag:** under the steering column

- 1) SRS frontal airbag
- 2) SRS side airbag

- 3) SRS curtain airbag
- 4) SRS knee airbag

102093

## 1-44 Seat, seatbelt and SRS airbags/SRS airbag (Supplemental Restraint System airbag)

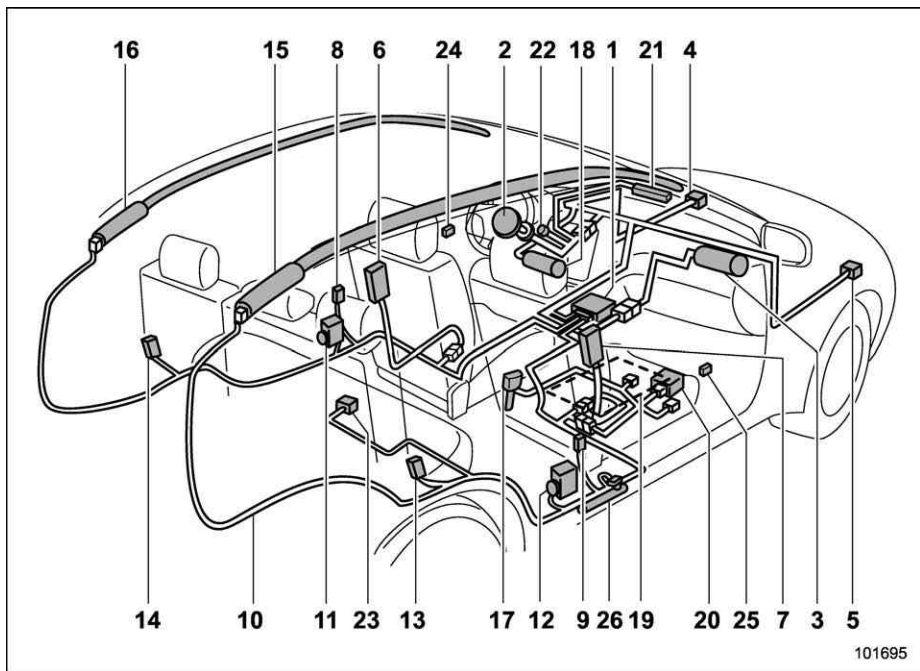

- |  |   |
|--|---|
| 1) Airbag control module (including impact sensor and rollover sensor) | 6) Side airbag module (driver's side)                 |
| 2) Frontal airbag module (driver's side)                               | 7) Side airbag module (front passenger's side)        |
| 3) Frontal airbag module (front passenger's side)                      | 8) Side airbag sensor (center pillar left-hand side)  |
| 4) Front sub sensor (left-hand side)                                   | 9) Side airbag sensor (center pillar right-hand side) |
| 5) Front sub sensor (right-hand side)                                  | 10) Airbag wiring                                     |

- 11) Seatbelt pretensioner (driver's side)
- 12) Seatbelt pretensioner (front passenger's side)
- 13) Curtain airbag sensor (rear wheel house right-hand side)
- 14) Curtain airbag sensor (rear wheel house left-hand side)
- 15) Curtain airbag module (right-hand side)
- 16) Curtain airbag module (left-hand side)
- 17) Seatbelt buckle switch (front passenger's side)
- 18) Knee airbag module (driver's side)
- 19) Front passenger's occupant detection system sensor
- 20) Front passenger's occupant detection control module
- 21) Front passenger's frontal airbag ON and OFF indicator
- 22) SRS airbag system warning light
- 23) Satellite sensing sensor (under the rear center seat)
- 24) Front door impact sensor (left-hand side)
- 25) Front door impact sensor (right-hand side)
- 26) Lap belt pretensioner (front passenger's side)

101695



## ■ SUBARU advanced frontal airbag system

Your vehicle is equipped with a SUBARU advanced frontal airbag system that complies with the new advanced frontal airbag requirements in the amended Federal Motor Vehicle Safety Standard (FMVSS) No. 208.

The SUBARU advanced frontal airbag system automatically determines the deployment force of the driver's SRS frontal airbag at the time of deployment as well as whether or not to activate the front passenger's SRS frontal airbag and, if activated, the deployment force of the SRS frontal airbag at the time of deployment.

Your vehicle has warning labels on the driver's and front passenger's sun visors beginning with the phrase "EVEN WITH ADVANCED AIR BAGS" and a tag attached to the glove box lid beginning with the phrase "Even with Advanced Air Bags". Make sure that you carefully read the instructions on the warning labels and tag.

Always wear your seatbelt. The SUBARU advanced frontal airbag system is a supplemental restraint system and must be used in combination with a seatbelt. All occupants should wear a seatbelt or be seated in an appropriate child restraint

system.

For the locations of the SRS airbags, refer to "Components" 1-43.

In a moderate to severe frontal collision, the following components deploy.

- SRS frontal airbag for driver
- SRS frontal airbag for front passenger
- SRS knee airbag for driver
- SRS curtain airbag\*1

\*1: When an offset frontal collision that is severe enough to deploy the front airbag occurs.

These components supplement the seatbelts by reducing the impact to the occupant's head, chest and knees.

### ▼ Driver's SRS frontal airbag

The driver's SRS frontal airbag uses a dual stage inflator. The inflator operates in different ways depending on the severity of impact.

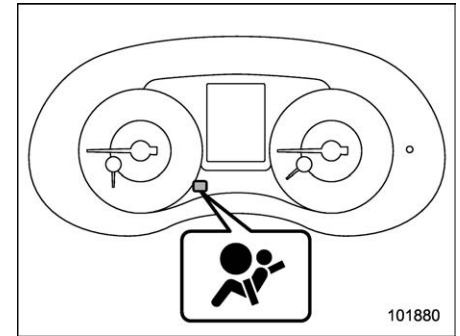

### SRS airbag system warning light

Have the system inspected by your SUBARU dealer immediately if the SRS airbag system warning light illuminates.

## NOTE

**The driver's SRS side airbag and SRS curtain airbag are not controlled by the SUBARU advanced frontal airbag system.**

### ▼ Front passenger's SRS frontal airbag

The front passenger's SRS frontal airbag uses a dual stage inflator. The inflator operates in different ways depending on the severity of impact.

The occupant detection system sensor is installed under the seat upholstery and

monitors the physique and posture of the front passenger. Using this information, the occupant detection system determines whether the front passenger's SRS frontal airbag should be deployed or not.

The occupant detection system may not inflate the front passenger's SRS frontal airbag even when the driver's SRS frontal airbag deploys. This is normal. In this case, although the front passenger's SRS frontal airbag does not operate, the front passenger's seatbelt pretensioner operates with the driver's seatbelt pretensioner. For details about the seatbelt pretensioner, refer to "Front seatbelt pretensioners" ¶ 1-17.

**CAUTION**

**Observe the following precautions. Failure to do so may prevent the SUBARU advanced frontal airbag system from functioning correctly or cause the system to fail.**

- **Do not apply any strong impact to the front passenger's seat such as by kicking.**
- **Do not let rear passengers rest their feet between the front seat-back and seat cushion.**
- **Do not spill liquid on the front passenger's seat. If liquid is**

**spilled, wipe it off immediately.**

- **Do not remove or disassemble the front passenger's seat.**
- **Do not install any accessory (such as an audio amplifier) other than a genuine SUBARU accessory under the front passenger's seat.**
- **Do not place anything (shoes, umbrella, etc.) under the front passenger's seat.**
- **Do not use the front passenger's seat with the head restraint removed.**
- **Do not leave any articles on the front passenger's seat or the seatbelt tongue and buckle engaged when you leave your vehicle.**
- **Do not put sharp object(s) on the seat or pierce the seat upholstery.**
- **Do not place a magnet near the seatbelt buckle and the seatbelt retractor.**
- **Do not use front seats with their backward-forward position and seatback not being locked into place securely. If any of them are not locked securely, adjust them**

**again. For adjusting procedure, refer to "Manual seat" ¶ 1-4 (models equipped with manual seats only).**

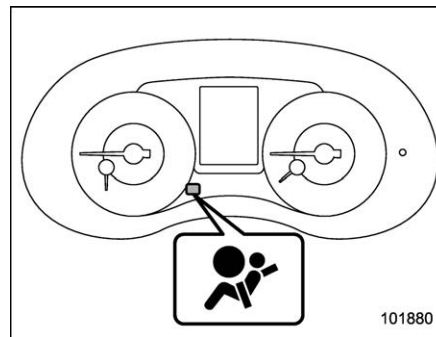
**SRS airbag system warning light**

If the seatbelt buckle switch and/or front passenger's occupant detection system have failed, the SRS airbag system warning light will illuminate. Have the system inspected by your SUBARU dealer immediately if the SRS airbag system warning light illuminates.

If your vehicle has sustained impact, this may affect the proper function of the SUBARU advanced frontal airbag system. Have your vehicle inspected at your SUBARU dealer. Do not let anyone use the front passenger's seat while you are

driving the vehicle to your SUBARU dealer.

## NOTE

The front passenger's SRS side airbag and SRS curtain airbag are not controlled by the SUBARU advanced frontal airbag system.

### ▼ Passenger's frontal airbag ON and OFF indicators

Refer to "Front passenger's frontal airbag ON and OFF indicators" 3-16.

### ▼ Occupant detection system

The occupant detection system sensor is installed under the seat upholstery and monitors the physique and posture of the front passenger. Using this information, the occupant detection system determines whether the front passenger's SRS frontal airbag should be deployed or not.



ON /  2: Front passenger's frontal airbag ON indicator

OFF /  2: Front passenger's frontal airbag OFF indicator

If the front passenger's seat cushion is wet, this may adversely affect the ability of the system to determine deployment. If the seat cushion is wet, the front passenger should stop sitting on the front passenger's seat. Wipe off liquid from the seat immediately, let the seat dry naturally and then check the SRS airbag system warning light as follows.

- If the SRS airbag system warning light illuminates, keep the seat dry until the warning light turns off. If the SRS airbag system warning light stays on even when the seat has dried, do not allow anyone to sit on the front passenger's seat and have

the system checked by your SUBARU dealer.

- If the SRS airbag system warning light does not illuminate, check that the front passenger's frontal airbag ON and OFF indicators work properly. If the indicators do not work properly, do not allow anyone to sit on the front passenger's seat and have the system checked by your SUBARU dealer.

Also, if luggage or electronic devices are placed on the front passenger's seat, this may adversely affect the ability of the system to determine deployment. This may prevent the front passenger's frontal airbag ON and OFF indicators from working properly. Check that the indicators work properly.

When the OFF indicator turns off and the ON indicator illuminates, the front passenger's frontal airbag may deploy during a collision. Remove luggage and electronic devices from the front passenger's seat.



**CAUTION**

Electronic devices\* may affect the occupant detection system, especially under either of the following conditions.

- When placed on the front passenger's seat while connected to the accessory power outlet
- When used by the front passenger

\*Example: cell phones, laptops, portable music players, or electronic games

If either of the following situations occurs when using an electronic device in the vehicle, at first try to relocate that device to avoid it creating any interference.

- The SRS airbag system warning light illuminates.
- The front passenger's frontal airbag ON and OFF indicators operate erratically.

If the interference remains, stop using the device in the vehicle.

**NOTE**

This device complies with part 18 of the FCC Rules. This device may cause interference. If this device causes interference, consult the nearest SUBARU dealer. Also, for maintenance of the system, consult the nearest SUBARU dealer. This product may cause interference to radio equipment and should not be installed near maritime safety communications equipment or other critical navigation or communication equipment operating between 0.45-30 MHz.

▼ **Conditions in which front passenger's SRS frontal airbag is not activated**

The front passenger's SRS frontal airbag will not be activated when any of the following conditions are met regarding the front passenger's seat:

- The seat is empty.
- The seat is equipped with an appropriate child restraint system and an infant is restrained in it. (See WARNING that follows.)
- The front passenger's occupant detection system is malfunctioning.



**WARNING**

**NEVER INSTALL A CHILD SEAT IN THE FRONT PASSENGER'S SEAT EVEN IF THE FRONT PASSENGER'S SRS FRONTAL AIRBAG IS DEACTIVATED.** Be sure to install it in the REAR seat in a correct manner. Also, it is strongly recommended that any forward facing child seat or booster seat be installed in the REAR seat, and that even children who have outgrown a child restraint system be also seated in the REAR seat. This is because children sitting in the front passenger's seat may be killed or severely injured should the front passenger's SRS frontal airbag deploy. REAR seats are the safest place for children.



**CAUTION**

**When the front passenger's seat is occupied by an infant in an appropriate child restraint system, observe the following precautions.** Failure to do so may interfere with the proper operation of the occupant detection system, activating the front passenger's SRS frontal airbag even though that seat is occupied by

the infant in the child restraint system.

- Do not place any article (including electronic devices) on the seat other than the infant in the child restraint system.
- Do not place more than one infant in the child restraint system.

▽ If the front passenger's frontal airbag ON indicator illuminates and the OFF indicator turns off even when an infant or a small child is in a child restraint system (including booster seat)

1. Turn the ignition switch to the "LOCK"/"OFF" position.
2. Remove the child restraint system from the seat.
3. By referring to the child restraint manufacturer's recommendations as well as the child restraint system installation procedures in "Child restraint systems" 1-21, correctly install the child restraint system.
4. Turn the ignition switch to the "ON" position and make sure that the front passenger's frontal airbag ON indicator turns off and the OFF indicator illuminates.

If still the ON indicator remains illuminated while the OFF indicator turns off, take the following actions.

- Ensure that no article is placed on the seat other than the child restraint system and the child occupant.
- Ensure that the backward-forward position and seatback of front passenger's seat are locked into place securely by moving the seat back and forth.

If the ON indicator still remains illuminated while the OFF indicator turns off after taking relevant corrective actions described above, relocate the child restraint system to the rear seat and immediately contact your SUBARU dealer for an inspection.

## NOTE

**When a child who has outgrown a child restraint system or a small adult is seated in the front passenger's seat, the SUBARU advanced frontal airbag system may or may not activate the front passenger's SRS frontal airbag depending on the occupant's seating posture. Children should always wear a seatbelt when sitting in the seat irrespective of whether the airbag is deactivated or activated. If the front passenger's SRS frontal airbag is activated (the ON indicator remains illuminated**

**while the OFF indicator turns off), ensure that no article is placed on the seat other than the occupant.**

**If the ON indicator still remains illuminated while the OFF indicator turns off despite the fact that the actions noted above have been taken, seat the child/small adult in the rear seat and immediately contact your SUBARU dealer for an inspection. Even if the system has passed the dealer inspection, it is recommended that on subsequent trips the child/small adult always take the rear seat.**

Children who have outgrown a child restraint system should always wear the seatbelt irrespective of whether the airbag is deactivated or activated.

## ▼ Conditions in which front passenger's SRS frontal airbag is activated

The front passenger's SRS frontal airbag will be activated for deployment upon impact when any of the following conditions are met regarding the front passenger's seat.

- The seat is occupied by an adult.
- Certain items (e.g. jug of water) are placed on the seat.

▽ **If the passenger's frontal airbag OFF indicator illuminates and the ON indicator turns off even when the front passenger's seat is occupied by an adult**

This can be caused by the adult incorrectly sitting in the front passenger's seat.

1. Turn the ignition switch to the "LOCK"/"OFF" position.
2. Ask the front passenger to set the seatback to the upright position, sit up straight in the center of the seat cushion, correctly fasten the seatbelt, position his/her legs out forward, and adjust the seat to the rearmost position.
3. Turn the ignition switch to the "ON" position.

If the OFF indicator remains illuminated while the ON indicator remains off, take the following actions.

1. Turn the ignition switch to the "LOCK"/"OFF" position.
2. Make sure that the front passenger does not use a blanket, seat cushion, seat cover, seat heater or massager, etc.
3. If wearing excessive layers of clothing, the front passenger should remove any unnecessary items before sitting in the front passenger's seat, or should sit in a rear seat.

4. Turn the ignition switch to the "ON" position and wait 6 seconds to allow the system to complete self-checking. Following the system check, both indicators turn off for 2 seconds. Now, the ON indicator should illuminate while the OFF indicator remains off.

If the OFF indicator still remains illuminated while the ON indicator remains off, ask the occupant to move to the rear seat and immediately contact your SUBARU dealer for an inspection.

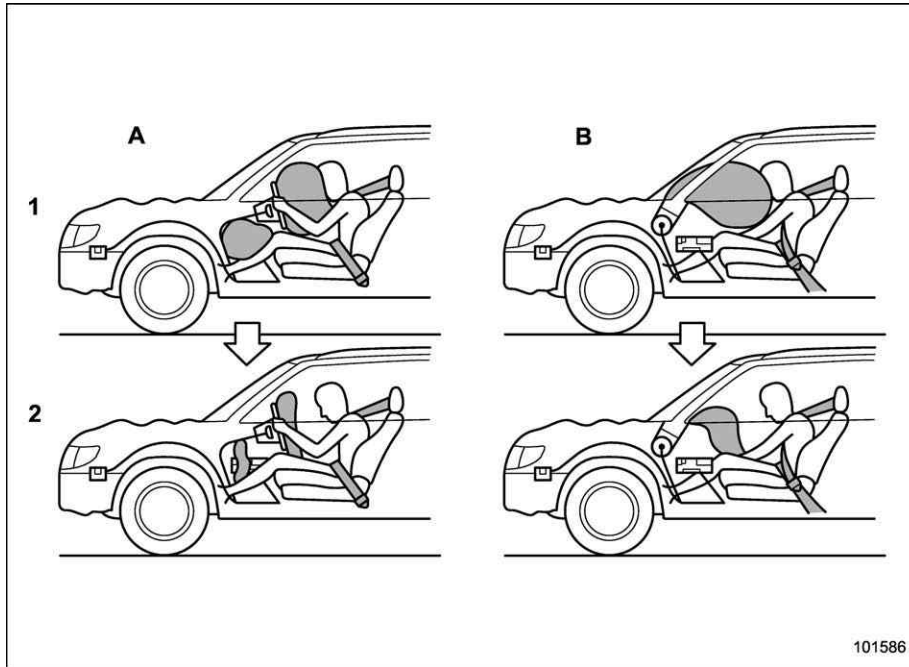
▼ **Operation**

- A) Driver's side  
 B) Passenger's side  
 1) SRS AIRBAGs deploy as soon as a collision occurs.  
 2) After deployment, SRS AIRBAGs start to deflate immediately so that the driver's vision is not obstructed.

The SRS airbags can function only when the ignition switch is in the "ON" position.

The SUBARU advanced frontal airbag system is designed to determine the activation or deactivation condition of the front passenger's SRS frontal airbag depending on the characteristic of item(s) or person on the front passenger's seat monitored by the front passenger's occupant detection system sensor. For this reason, only the driver's SRS frontal airbag may deploy in the event of a collision, but this does not mean failure of the system.

If the following sensors detect a predetermined amount of force during a frontal collision, the control module sends signals to the airbag module(s) (only driver's module or both driver's and front passenger's modules) instructing the module(s) to inflate the SRS frontal airbag(s).

- The front sub sensors
- The impact sensors in the airbag control module

On the driver's side, the SRS knee airbag also inflates with the SRS frontal airbag.

The driver's and front passenger's SRS frontal airbags use dual stage inflators. The two inflators of each airbag are triggered either sequentially or simultaneously, depending on the severity of impact, in the case of the driver's SRS frontal airbag and depending on the severity of impact and the characteristic of item(s) or person on the seat in the case of the front passenger's SRS frontal airbag.

#### ▼ After deployment

After deployment, the SRS airbag immediately starts to deflate so that the driver's vision is not obstructed and the driver's ability to maintain control of the vehicle is not impaired. The time required from detecting impact to the deflation of the SRS airbag after deployment is shorter than the blink of an eye.

Both when only the driver's SRS frontal airbag deploys and the driver's and front passenger's SRS frontal airbags deploy, the driver's and front passenger's seatbelt pretensioners operate at the same time.

Although it is highly unlikely that the SRS airbag would activate in a non-accident situation, should it occur, the SRS airbag will deflate quickly, not obscuring vision and will not interfere with the driver's ability to maintain control of the vehicle.

When the SRS airbag deploys, a sudden, fairly loud inflation noise will be heard and some smoke will be released. These occurrences are a normal result of the deployment. This smoke does not indicate a fire in the vehicle.



#### CAUTION

**Do not touch the SRS airbag system components around the steering wheel and dashboard with bare hands right after deployment. Doing so can cause burns because the components can be very hot as a result of deployment.**

#### ▼ Example of the type of accident

The driver's SRS frontal airbag and front passenger's SRS frontal airbag are designed as follows.

- To deploy in the event of an accident involving a moderate to severe frontal collision
- To function on a one-time-only basis

The driver's SRS frontal airbag and front passenger's SRS frontal airbag are not designed as follows.

- To deploy in most lesser frontal impacts\*1

- To deploy in most side or rear impacts or in most rollover accidents\*2

\*1: Because the necessary protection can be achieved by the seatbelt alone.

\*2: Because deployment of only the driver's SRS frontal airbag or both the driver's and front passenger's SRS frontal airbags would not protect the occupant in those situations.

SRS airbag deployment depends on the level of force experienced in the passenger compartment during a collision. That level differs from one type of collision to another, and it may have no bearing on the visible damage done to the vehicle itself.



▽ **Example of accident in which the driver's/driver's and front passenger's SRS frontal airbag(s) will most likely deploy**

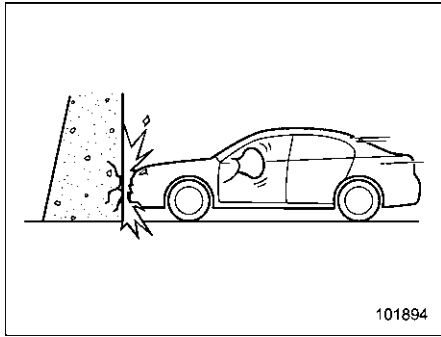

A head-on collision against a thick concrete wall at a vehicle speed of 12 to 19 mph (20 to 30 km/h) or higher activates only the driver's SRS frontal airbag or both driver's and front passenger's SRS frontal airbags. The airbag(s) will also be activated when the vehicle is exposed to a frontal impact similar in fashion and magnitude to the collision described above.

▽ **Examples of the types of accidents in which it is possible that the driver's/driver's and front passenger's SRS frontal airbag(s) will deploy**

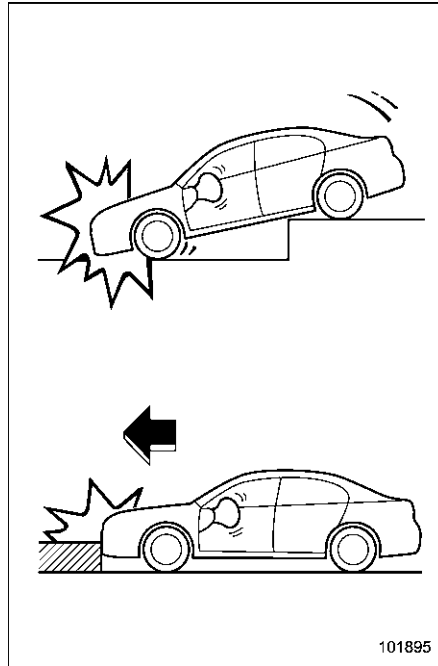

Only the driver's SRS frontal airbag or both driver's and front passenger's SRS frontal airbags may be activated when the vehicle sustains a hard impact in the undercarriage area from the road surface (such as when the vehicle plunges into a deep ditch, is severely impacted or knocked hard against an obstacle on the road such as a curb).

▽ **Examples of the types of accidents in which deployment of the driver's/ driver's and front passenger's SRS frontal airbag(s) is unlikely to occur**

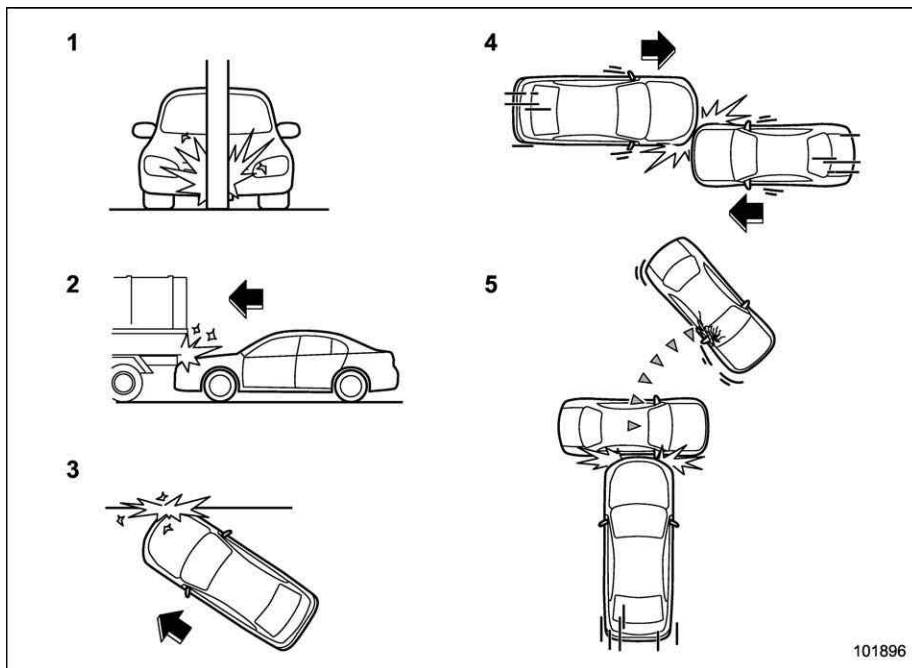

- 1) The vehicle strikes an object, such as a telephone pole or sign pole.
- 2) The vehicle slides under the load bed of a truck.
- 3) The vehicle sustains an oblique offset frontal impact.
- 4) The vehicle sustains an offset frontal collision.
- 5) The vehicle strikes an object that can move or deform, such as a parked vehicle.

There are many types of collisions which might not necessarily require deployment of driver's/driver's and front passenger's SRS frontal airbag(s). In the event of accidents like those illustrated, the driver's/driver's and front passenger's SRS frontal airbag(s) may not deploy depending on the level of accident forces involved.

▽ **Examples of the types of accidents in which the driver's/driver's and front passenger's SRS frontal airbag(s) are not designed to deploy in most cases**

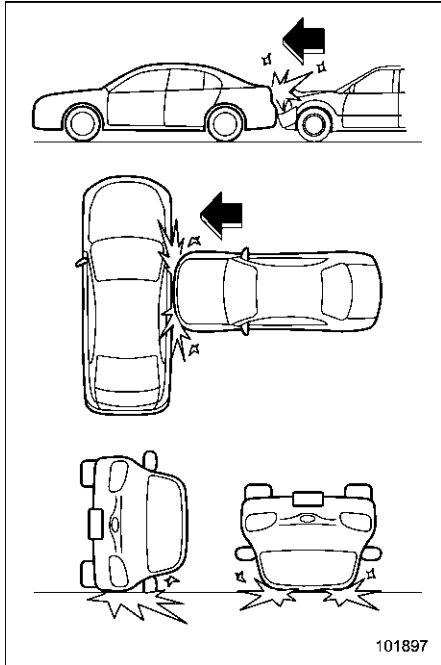

The driver's and front passenger's SRS

frontal airbags are not designed to deploy in most of the following cases.

- If the vehicle is struck from the side or from behind.
- If the vehicle rolls onto its side or roof.
- If the vehicle is involved in a low-speed frontal collision.

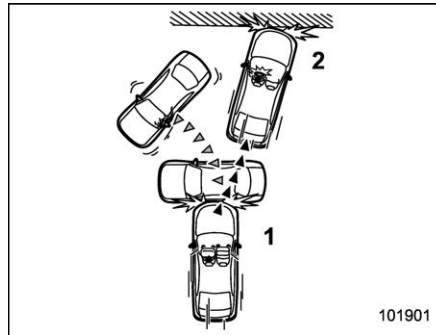

- 1) First impact
- 2) Second impact

In an accident where the vehicle is impacted more than once, the driver's and/or front passenger's SRS frontal airbag(s) will deploy only once on the first impact.

Example: In the case of a double collision, first with another vehicle, then against a concrete wall in immediate succession,

once either or both of the driver's and front passenger's SRS frontal airbags is/are activated on the first impact, it/they will not be activated on the second impact.

### ■ SRS side airbag and SRS curtain airbag



#### ▼ SRS side airbag

The SRS side airbag is stored in the door side of each front seat seatback, which bears an "SRS AIRBAG" label.

In a moderate to severe side impact collision, the SRS side airbag on the impacted side of the vehicle deploys between the occupant and the door panel and supplements the seatbelt by reducing the impact on the occupant's chest and waist. The SRS side airbag operates only for front seat occupants.

▼ **SRS curtain airbag**

Your vehicle is equipped with a SUBARU SRS curtain airbag system that complies with the Federal Motor Vehicle Safety Standard (FMVSS) No. 226.

The SRS curtain airbag on each side of the cabin is stored in the roof side (between the front pillar and a point over the rear seat). An "SRS AIRBAG" mark is located at the top of each center pillar.

In a moderate to severe side impact collision, the SRS curtain airbag on the impacted side of the vehicle deploys between the occupant and the side window and supplements the seatbelt by reducing the impact on the occupant's head.

In a rollover, SRS curtain airbags on both sides of the vehicle deploy between the occupant and the side window and supplement the seatbelt by reducing the impact to the occupant's head.

In an offset frontal collision, SRS curtain airbags on both sides of the vehicle deploy between the occupant and the side window and supplement the seatbelt by reducing the impact to the occupant's head.

▼ **Operation**

The SRS side airbag and SRS curtain airbag can function only when the ignition switch is in the "ON" position.

The following airbags deploy independently of each other since each has its own impact sensor.

- Driver's SRS side airbag
- Front passenger's SRS side airbag
- SRS curtain airbag (right-hand side)
- SRS curtain airbag (left-hand side)

Therefore, they may not both deploy in the same accident. Also, the SRS side airbag and SRS curtain airbag deploys independently of the driver's and front passenger's SRS frontal airbags in the steering wheel and instrument panel.

An impact sensor, which senses impact force, is located in each of the following locations.

- In the left and right front doors
- In the left and right center pillars
- In the left and right rear wheel houses
- Under the rear center seat
- On both sides of the radiator panel (frontal impact sensor)

The rollover sensor and frontal impact sensor are located inside the airbag

control module, which is located under the center of the instrument panel.

▼ In cases of rollover accident or side collisions, the following components will operate simultaneously

Impact sensors affected		SRS side airbags		SRS curtain airbags		Seatbelt pretensioner (shoulder belt pretensioner only)	
		Impacted side	Non-impacted side	Impacted side	Non-impacted side	Impacted side	Non-impacted side
Both of the sensors together sense an impact force	Impact sensor in front doors	○	—	○	—	○	—
	Impact sensor under rear center seat						
Both of the sensors together sense an impact force	Impact sensor in center pillars	○	—	○	—	—	—
	Impact sensor under rear center seat						
Both of the sensors together sense an impact force	Impact sensor in rear wheel houses	—	—	○	—	—	—
	Impact sensor under rear center seat						
Rollover sensor in airbag control module		—	—	○	○	○	○

○: Activated  
 -: Not activated

**NOTE**

The SRS side airbag and SRS curtain airbag deploy even when no one occupies the seat on the side on which an impact is applied.

▼ **In case of frontal collision**

The SRS curtain airbags are designed to deploy in the following cases.

- The driver's SRS frontal airbag deploys in a frontal collision.
- The driver's and front passenger's SRS frontal airbags deploy in a frontal collision.
- The system determines that the collision is an offset frontal collision.

The SRS curtain airbags are basically designed not to deploy in the following cases.

- The SRS frontal airbags do not deploy.
- The system determines that the collision is other than an offset frontal collision.

▼ **After deployment**

After the deployment, the SRS side airbag immediately starts to deflate. The time required from detection of an impact to deflation of an SRS side airbag after deployment is shorter than the blink of an eye.

The SRS curtain airbag remains inflated for a while following deployment then slowly deflates.

The SRS side airbag and SRS curtain airbag deploy even when no one occupies the seat on the side on which an impact is applied.

When the SRS side airbag and SRS curtain airbag deploy, a sudden, fairly loud inflation noise will be heard and some smoke will be released. These occurrences are a normal result of the deployment. This smoke does not indicate a fire in the vehicle.

 **CAUTION**

**Do not touch the SRS side airbag system components around the front seat seatback with bare hands right after deployment. Doing so can cause burns because the components can be very hot as a result of deployment.**

**After deployment, do not touch any part of the SRS curtain airbag system (from the front pillar to the part of the roof side over the rear seat). Doing so can cause burns because the components can be very hot as a result of deployment.**

▼ **Example of the type of accident**

The SRS side airbag and SRS curtain airbag are designed as follows:

- To deploy in the event of an accident involving a moderate to severe side impact collision

- To function on a one-time-only basis

The SRS side airbag and SRS curtain airbag are not designed to deploy in the following cases.

- In most lesser side impact
- In most frontal or most rear impacts (because the SRS side airbag and SRS curtain airbag deployment would not protect the occupant in those situations.)

The SRS curtain airbags are also designed to deploy when the vehicle is in an extremely inclined state such as during a rollover. They are not designed to deploy in most lesser inclined state.

The SRS side airbag and SRS curtain airbag deployment depend on the level of force experienced in the passenger compartment during a side impact collision. That level differs from one type of collision to another, and it may have no bearing on the visible damage done to the vehicle itself.

▽ Example of the type of accident in which the SRS side airbag will most likely deploy.

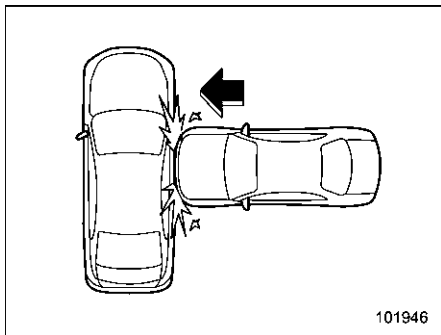

A severe side impact near the front seat.

▽ **Examples of the types of accidents in which the SRS curtain airbag will most likely deploy.**

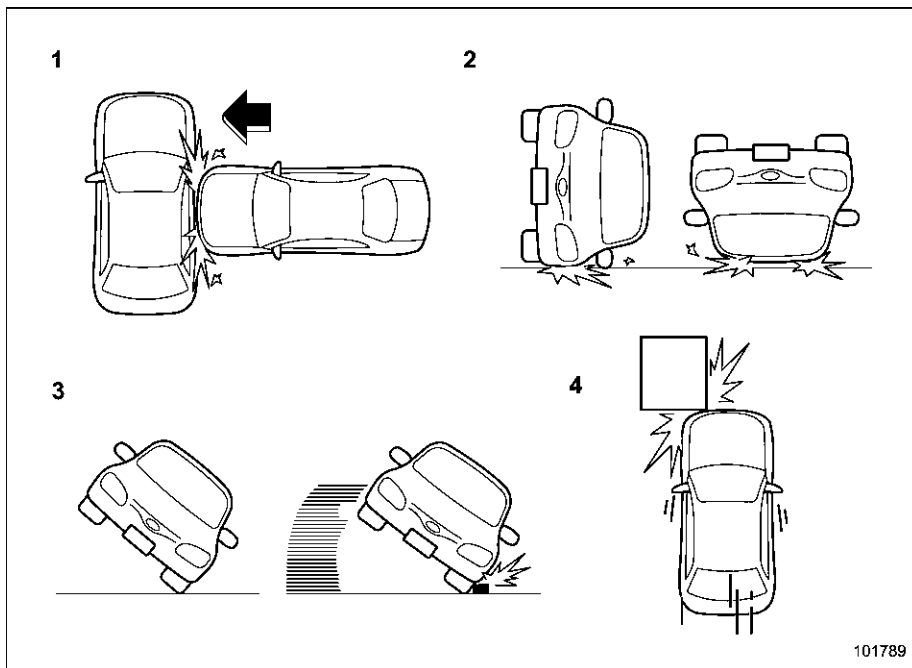

- 1) The vehicle is involved in a severe side impact near the front seat or the rear seat.
- 2) The vehicle rolls onto its side or the roof.
- 3) The angle of vehicle tip-up is marginal or the skidding vehicle's tires hit a curbstone laterally.
- 4) An offset frontal collision that is severe enough to deploy the front airbag.



▽ **Examples of the types of accidents in which it is possible that the SRS side airbag and the SRS curtain airbag will deploy.**

- 1) Hitting a curb, edge of pavement or hard surface
- 2) Falling into or jumping over a deep hole
- 3) Landing hard or vehicle falling

It is possible that the SRS side and curtain airbags will deploy if a serious impact occurs to the underside of your vehicle. Some examples are shown in the illustration.

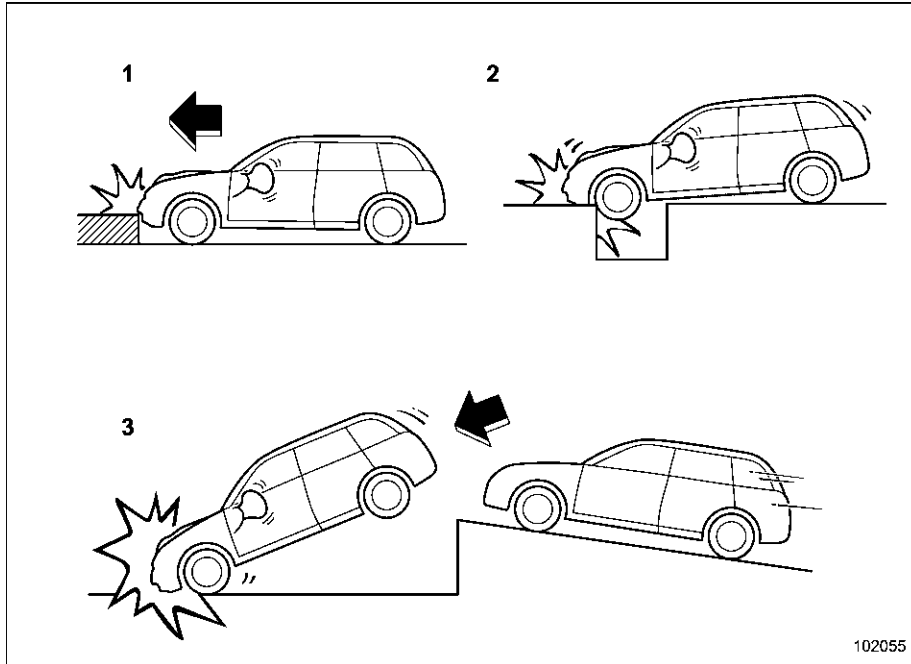

▽ **Examples of the types of accidents in which the SRS side airbag is unlikely to deploy.**

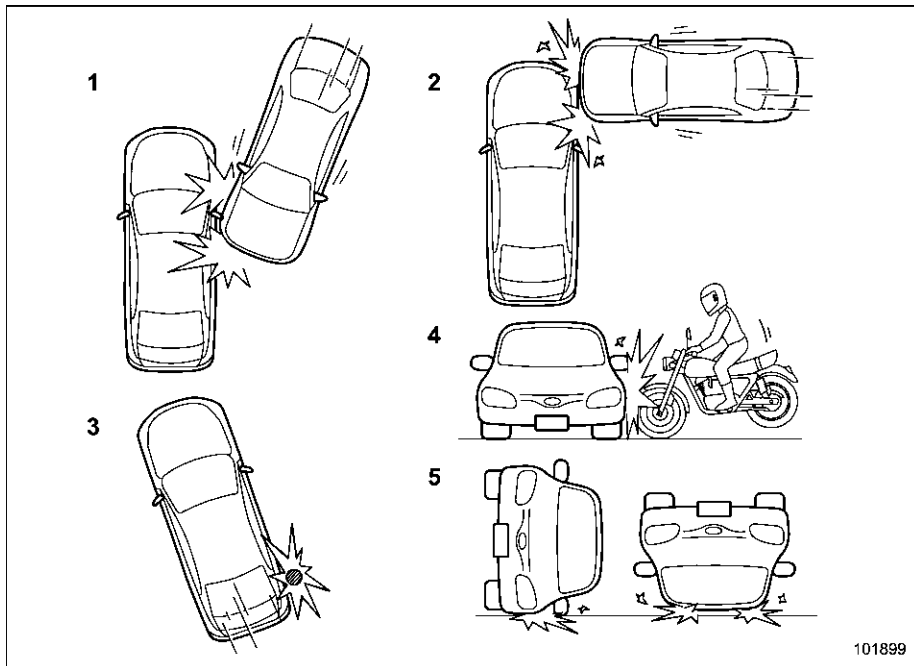

- 1) The vehicle is involved in an oblique side-on impact.
- 2) The vehicle is involved in a side-on impact in an area outside the vicinity of the passenger compartment.
- 3) The vehicle strikes a telephone pole or similar object.
- 4) The vehicle is involved in a side-on impact from a motorcycle.
- 5) The vehicle rolls onto its side or the roof.

There are many types of collisions which might not necessarily require the SRS side airbag deployment. In the event of accidents like those illustrated, the SRS side airbag may not deploy depending on the level of accident forces involved.

▽ **Examples of the types of accidents in which the SRS curtain airbag is unlikely to deploy.**

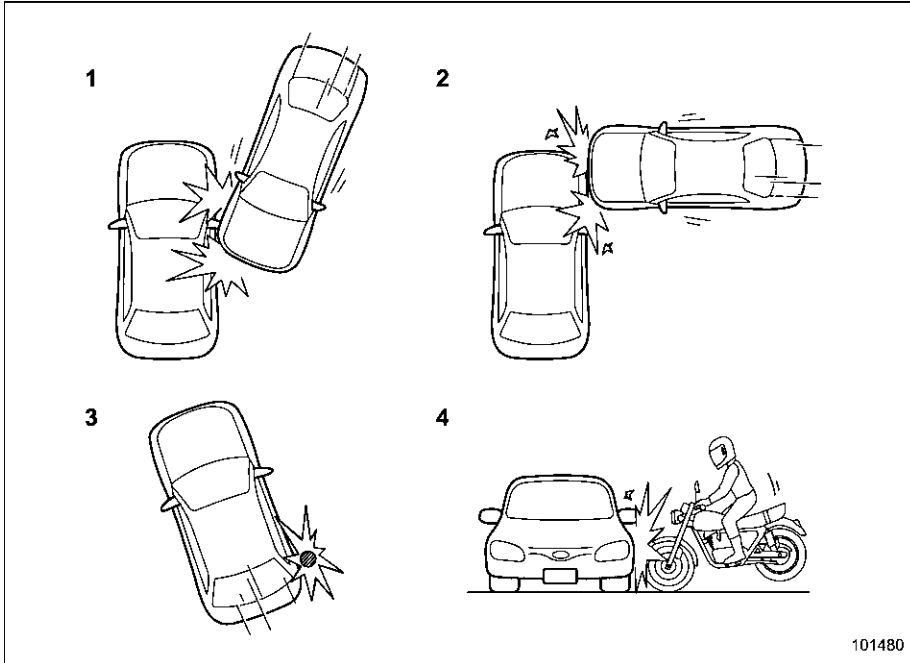

- 1) The vehicle is involved in an oblique side-on impact.
- 2) The vehicle is involved in a side-on impact in an area outside the vicinity of the passenger compartment.
- 3) The vehicle strikes a telephone pole or similar object.
- 4) The vehicle is involved in a side-on impact from a motorcycle.

There are many types of collisions which might not necessarily require SRS curtain airbag deployment. In the event of accidents like those illustrated, the SRS curtain airbag may not deploy depending on the level of accident forces involved.

▽ **Examples of the types of accidents in which the SRS side airbag and SRS curtain airbag are not designed to deploy in most cases**

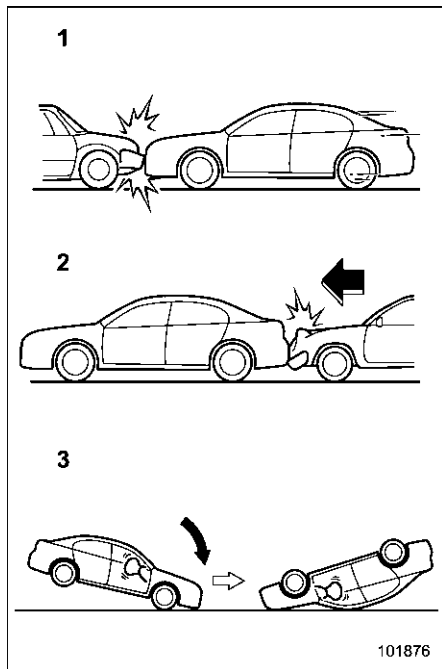

- 1) The vehicle is involved in frontal collision with another vehicle (moving or station-

ary).

- 2) The vehicle is struck from behind.
- 3) The vehicle pitches end over end.

In the event of accidents like those illustrated, the SRS side airbag and SRS curtain airbag are not designed to deploy in most cases.

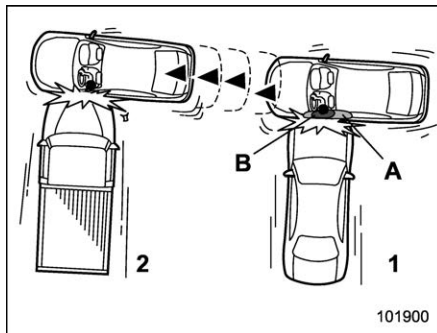

- 1) First impact
- 2) Second impact
- A) SRS curtain airbag
- B) SRS side airbag

In an accident where the vehicle is struck from the side more than once, the SRS side airbag and SRS curtain airbag deploy only once on the first impact.

Example: In the case of a double side impact collision, first with one vehicle and immediately followed by another from the

same direction, once the SRS side airbag and SRS curtain airbag are activated on the first impact, they will not be activated on the second.

## ■ SRS airbag system monitors

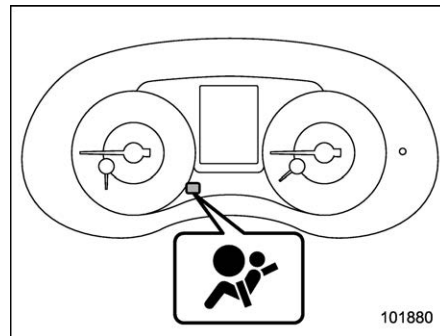

### SRS airbag system warning light

A diagnostic system continually monitors the readiness of the SRS airbag system (including front seatbelt pretensioners) while the vehicle is being driven. The SRS airbag system warning light will show normal system operation by illuminating for approximately 6 seconds when the ignition switch is turned to the "ON" position.

The following components are monitored by the indicator:

- Front sub sensor
  - Right-hand side
  - Left-hand side
- Airbag control module (including impact sensor and rollover sensor)
- Frontal airbag module
  - Driver's side
  - Front passenger's side
- Knee airbag module (driver's side)
- Side airbag sensor
  - Center pillar right-hand side
  - Center pillar left-hand side
- Front door impact sensor
  - Right-hand side
  - Left-hand side
- Side airbag module
  - Driver's side
  - Front passenger's side
- Curtain airbag sensor
  - Rear wheel house right-hand side
  - Rear wheel house left-hand side
- Curtain airbag module
  - Right-hand side
  - Left-hand side
- Satellite safing sensor (under the rear center seat)
- Seatbelt pretensioner
  - Driver's side

- Front passenger's side
- Lap belt pretensioner (front passenger's side)
- Seatbelt buckle switch (front passenger's side)
- Front passenger's occupant detection system sensor
- Front passenger's occupant detection control module
- Front passenger's frontal airbag ON and OFF indicator
- All related wiring



#### WARNING

If the warning light exhibits any of the following conditions, there may be a malfunction in the seatbelt pretensioners and/or SRS airbag system.

- Flashing or flickering of the warning light
- No illumination of the warning light when the ignition switch is first turned to the "ON" position
- Continuous illumination of the warning light
- Illumination of the warning light while driving

**Immediately take your vehicle to your nearest SUBARU dealer to**

have the system checked. Unless checked and properly repaired, the seatbelt pretensioners and/or SRS airbag will not operate properly in the event of a collision, which may increase the risk of injury.

## ■ SRS airbag system servicing



### WARNING

- When discarding an airbag module or scrapping the entire vehicle damaged by a collision, consult your SUBARU dealer.
- The SRS airbag has no user-serviceable parts. Do not use electrical test equipment on any circuit related to the SRS airbag system. For required servicing of the SRS airbag, consult your nearest SUBARU dealer. Tampering with or disconnecting the system's wiring could result in accidental inflation of the SRS airbag or could make the system inoperative, which may result in serious injury.



### CAUTION

If you need service or repair in areas indicated in the following list, have the work performed by an authorized SUBARU dealer. The SRS airbag control module, impact sensors and airbag modules are stored in these areas.

- Under the center of the instrument panel
- On both the right and left sides at the front of the vehicle
- Steering wheel and column and nearby areas
- Bottom of the steering column and nearby areas
- Top of the dashboard on front passenger's side and nearby areas
- Each front seat and nearby area
- Inside each center pillar
- Inside each front door
- In each roof side (from the front pillar to a point over the rear seat)
- Between the rear seat cushion and rear wheel house on each side
- Under the rear center seat

In the event that the SRS airbag is deployed, replacement of the system should be performed only by an authorized SUBARU dealer. When the components of the SRS airbag system are replaced, use only genuine SUBARU parts.

### NOTE

In the following cases, contact your SUBARU dealer as soon as possible.

- The front part of the vehicle was involved in an accident in which only the driver's SRS frontal airbag or both driver's and front passenger's SRS frontal airbags did not deploy.
- The pad of the steering wheel, the cover over the front passenger's SRS frontal airbag, or either roof side (from the front pillar to a point over the rear seat) is scratched, cracked, or otherwise damaged.
- The center pillar, front door, rear wheel house or rear sub frame, or an area near these parts, was involved in an accident in which the SRS side airbag and SRS curtain airbag did not deploy.
- The fabric or leather of either the front seatback and seat cushion is cut, frayed, or otherwise damaged.
- The rear part of the vehicle was

involved in an accident.

### ■ Precautions against vehicle modification



### WARNING

To avoid accidental activation of the system or rendering the system inoperative, which may result in serious injury, no modifications should be made to any components or wiring of the SRS airbag system.

This includes following modifications.

- Installation of custom steering wheels
- Attachment of additional trim materials to the dashboard
- Installation of custom seats
- Replacement of seat fabric or leather
- Installation of additional fabric or leather on the front seat
- Attachment of a hands-free microphone or any other accessory to a front pillar, a center pillar, a rear pillar, the windshield, a side window, an assist grip, or any other cabin surface that would be

near a deploying SRS curtain airbag.

- Installation of additional electrical/electronic equipment such as a mobile two-way radio on or near the SRS airbag system components and/or wiring is not advisable. This could interfere with proper operation of the SRS airbag system.



### CAUTION

Do not perform any of the following modifications. Such modifications can interfere with proper operation of the SRS airbag system.

- Attachment of any equipment (bush bar, winches, snow plow, skid plate, etc.) other than genuine SUBARU accessory parts to the front end.
- Modification of the suspension system or front end structure.
- Installation of a tire of different size and construction from the tires specified on the vehicle placard attached to the driver's door pillar or specified for individual vehicle models in this Owner's Manual.

- Attachment of any equipment (side steps or side sill protectors, etc.) other than genuine SUBARU accessory parts to the side body.

Always consult your SUBARU dealer if you want to install any accessory parts on your vehicle.

### ■ How to contact the vehicle manufacturer concerning modifications for persons with disabilities that may affect the advanced airbag system

Changing or moving any parts of the front seats, rear seats, seatbelts, front bumper, front side frame, radiator panel, instrument panel, combination meter, steering wheel, steering column, tire, suspension or floor panel can affect the operation of the SUBARU advanced airbag system. If you have any questions, you may contact the following SUBARU distributors.

<Continental U.S., Alaska and the District of Columbia>  
Subaru of America, Inc.  
Customer Retailer Services Department  
One Subaru Drive  
P.O. Box 9103

Camden, NJ 08101-9877  
1-800-SUBARU3 (1-800-782-2783)

<Hawaii>

Subaru Hawaii  
2850 Pukoloa Street, Ste. 101,  
Honolulu, HI 96819  
877-215-0338

<Guam>

Shen's Corporation dba Prestige Automobiles  
491 East Marine Corps Drive,  
Dededo, Guam 96929  
671-633-2698

<Puerto Rico>

Trebol Motors  
296 Marginal JF Kennedy, San Juan,  
Puerto Rico  
787-793-2828

<Canada>

Subaru Canada, Inc.  
Consumer Support Department  
560 Suffolk Court, Mississauga, Ontario  
L5R 4J7  
1-800-894-4212

**1-68** *Seat, seatbelt and SRS airbags/SRS airbag (Supplemental Restraint System airbag)*

---

There are currently no SUBARU distributors in any other U.S. territories. If you are in such an area, please contact the SUBARU distributor or dealer from which you bought your vehicle.



<b>Keys</b> .....	2-2	<b>Remote keyless entry system</b> .....	2-18
Models without “keyless access with push-button start system” .....	2-2	Locking the doors .....	2-19
Models with “keyless access with push-button start system” .....	2-2	Unlocking the doors .....	2-19
Key number plate.....	2-3	Opening the trunk lid.....	2-20
<b>Door locks</b> .....	2-4	Vehicle finder function.....	2-20
Locking and unlocking from the outside.....	2-4	Sounding a panic alarm .....	2-20
Locking and unlocking from the inside.....	2-5	Selecting audible signal operation (models without “keyless access with push-button start system”).....	2-20
Battery drainage prevention function.....	2-5	Replacing the battery.....	2-21
<b>Power door locking switches</b> .....	2-6	Replacing lost transmitters .....	2-21
Key lock-in prevention function.....	2-7	Certification for Remote keyless entry system.....	2-21
<b>Keyless access with push-button start system (if equipped)</b> .....	2-7	<b>Anti-theft system</b> .....	2-22
Safety precautions .....	2-7	Immobilizer.....	2-22
Locking and unlocking by holding the access key fob .....	2-10	Alarm system .....	2-24
Unlock using PIN Code Access .....	2-12	<b>Child safety locks</b> .....	2-31
Power saving function .....	2-13	<b>Windows</b> .....	2-31
Selecting audible signal operation.....	2-14	Power window operation by driver.....	2-32
Warning chimes and warning indicator.....	2-14	Power window operation by passengers .....	2-34
Disabling keyless access function.....	2-14	Off delay function.....	2-35
When access key fob does not operate properly ...	2-16	Initialization of power window .....	2-35
Replacing battery of access key fob.....	2-16	<b>Trunk lid</b> .....	2-35
Replacing access key fob .....	2-16	To open and close the trunk lid from outside .....	2-36
Certification for keyless access with push-button start system.....	2-16	To open the trunk lid from inside .....	2-36
Tips .....	2-17	Internal trunk lid release handle.....	2-37
		<b>Moonroof (if equipped)</b> .....	2-38
		Moonroof switches .....	2-39
		Sunshade .....	2-40

## Keys

### CAUTION

When traveling in an airplane, do not press the button of the key. If any button of the key is pressed, radio waves are emitted and may affect the operation of the airplane. When carrying the key in a bag, take measures to prevent the buttons from being pressed accidentally.

### NOTE

Press the buttons of the key to lock/unlock with the remote keyless entry system. For details, refer to "Remote keyless entry system" 2-18.

### Models without "keyless access with push-button start system"

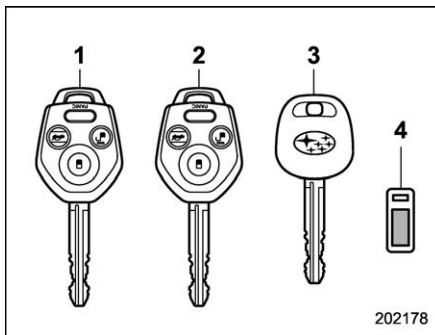

- 1) Master key
- 2) Submaster key
- 3) Sub key
- 4) Key number plate

Three types of keys are provided for your vehicle.

### CAUTION

Do not attach a large key holder or key case to either key. If it bangs against your knees while you are driving, it could turn the ignition switch from the "ON" position to the "ACC" or "LOCK" position, thereby stopping the engine.

### Models with "keyless access with push-button start system"

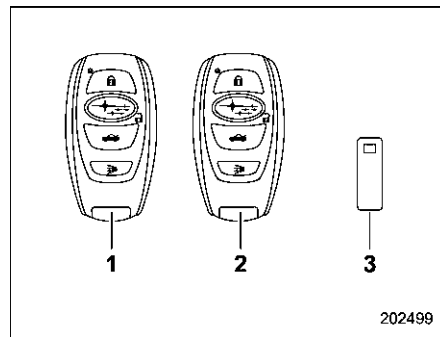

- 1) Access key fob (main)
- 2) Access key fob (sub)
- 3) Key number plate

The vehicle has two access key fobs and a

key number plate. For details about the key number plate, refer to “Key number plate” 2-3.

An emergency key is attached to each access key fob. The emergency key is used for the following operations.

- Locking and unlocking the driver’s door
- Locking and unlocking the glove box

You cannot unlock the glove box without using the emergency key. You can keep the glove box locked when you leave your vehicle and the access key fob (with the emergency key removed) at a parking facility.

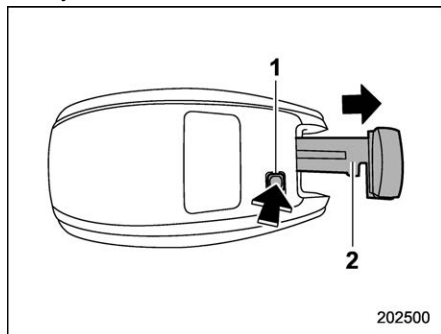

- 1) Release button
- 2) Emergency key

While pressing the release button of the

access key fob, take out the emergency key.

### CAUTION

If the access key fob is dropped, the integrated emergency key inside may become loose. Be careful not to lose the emergency key.

### NOTE

- **The access key fob is always communicating with the vehicle and is continuously using the battery. Although the life of the battery varies depending on the operating conditions, it is approximately 1 to 2 years. If the battery becomes fully discharged, replace it with a new one.**
- If an access key fob is lost, it is recommended that the remaining access key fobs be reregistered. For reregistration of an access key fob, contact a SUBARU dealer.
- Up to 7 access key fobs can be registered for one vehicle. For a spare access key fob, contact a SUBARU dealer.
- Do not leave the access key fob in the storage spaces inside the vehicle. Vibrations can damage the key or turn on the switch, possibly resulting in a

lockout.

## ■ Key number plate

### CAUTION

Carefully store the key number plate. It is necessary for vehicle repair and additional registration of access key fobs.

The key number is stamped on the key number plate attached to the key set. Write down the key number and keep it in another safe place, not in the vehicle. This number is needed to make a replacement key if you lose your key or lock it inside the vehicle. Refer to “Key replacement” 2-23.

## Door locks

### ■ Locking and unlocking from the outside

#### NOTE

If you unlock the driver's door with a key (including an emergency key) and open the door while the alarm system is armed, the alarm system is triggered and the vehicle's horn sounds. In this case, perform any of the following operations:

**Models with "keyless access with push-button start system":**

- Press any button on the access key fob (except when the battery of the access key fob is discharged).
- Turn the push-button ignition switch to the "ACC" position.

**Models without "keyless access with push-button start system":**

- Press any button on the remote transmitter (except when the transmitter battery is discharged).
- Insert the key into the ignition switch and turn the ignition switch to the "ON" position.

For details about the alarm system, refer to "Alarm system" 2-24.

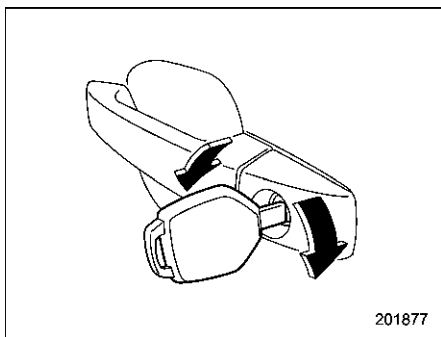

201877

To lock the driver's door from the outside with the key, turn the key toward the front. To unlock the door, turn the key toward the rear. Pull the outside door handle to open an unlocked door.

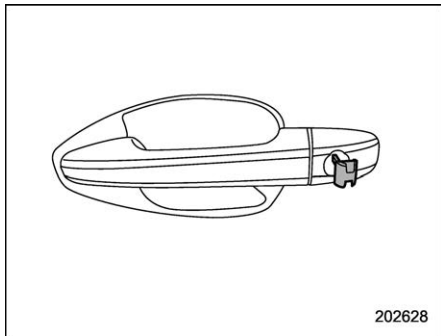

202628

#### NOTE

The emergency key is directional. If the key cannot be inserted, change the direction that the grooved side is facing and insert it again.

To lock the door from outside without the key, the following methods are available.

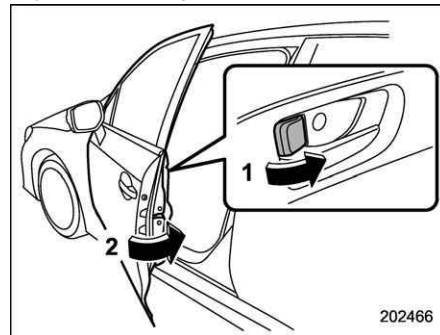

202466

#### Locking using lock lever

- 1) Rotate the lock lever forward.
- 2) Close the door.

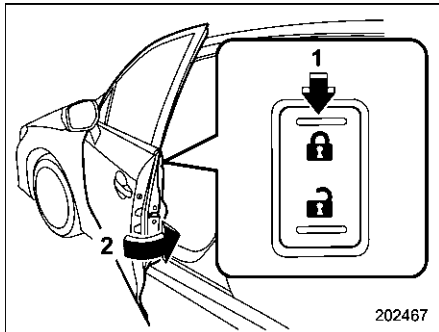

202467

#### Locking using power door locking switch

- 1) Press the front side (lock side) of the power door locking switch.
- 2) Close the door.

In this case, all closed doors are locked at the same time.

Always make sure that all doors and the trunk lid are locked before leaving your vehicle.

#### NOTE

**Make sure that you do not leave the key inside the vehicle when locking the doors from the outside without the key.**

#### Locking and unlocking from the inside

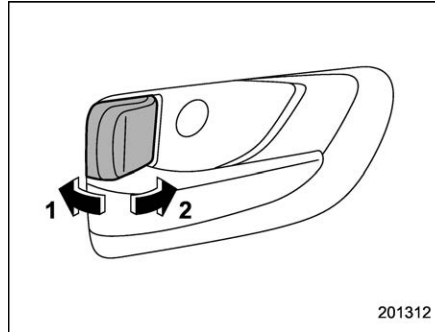

201312

- 1) Unlock
- 2) Lock

To lock the door from the inside, rotate the lock lever forward. To unlock the door from the inside, rotate the lock lever rearward.

The red mark on the lock lever appears when the door is unlocked.

Pull the inside door handle to open an unlocked door.

Always make sure that all doors and the trunk lid are closed before starting to drive.

#### WARNING

Keep all doors locked when you drive, especially when small children are in your vehicle.

Along with the proper use of seatbelts and child restraints, locking the doors reduces the chance of being thrown out of the vehicle in an accident.

It also helps prevent passengers from falling out by preventing a door from being accidentally opened, and intruders from unexpectedly opening doors and entering your vehicle.

#### Battery drainage prevention function

If a door is not completely closed, the interior lights will remain illuminated as a result. However, several lights will be automatically turned off by the battery drainage prevention function to prevent the battery from discharging. The following interior lights will be affected by this function.

Item	Switch position	Automatically turning off
Map lights*	OFF*	Approximately 20 minutes later
Dome light	DOOR	Approximately 20 minutes later
Ignition switch light	—	Approximately 20 minutes later
Trunk light	—	Approximately 20 minutes later

\*: The battery drainage prevention function affects only the map lights on models with the moonroof, and only when the map light switches are in the OFF position. The map lights on models without the moonroof do not turn off automatically, so push the light switches manually to turn them off.

The operational/non-operational setting of this function can be changed by a SUBARU dealer. Contact your SUBARU dealer to change the setting.

### NOTE

- The factory setting (default setting) for this function is set as “operational”.
- When leaving the vehicle, make sure that all doors and the trunk lid are completely closed.
- The battery drainage prevention function does not operate while the key is in the ignition switch.

### Power door locking switches

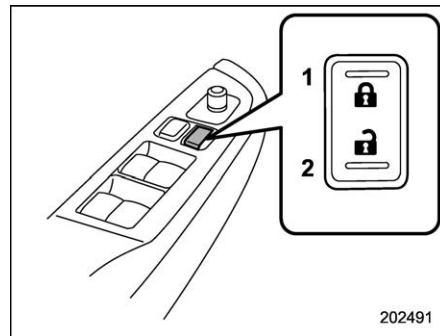

- 1) Lock
- 2) Unlock

All doors can be locked and unlocked by the power door locking switches located at the driver's side and the front passenger's side doors.

To lock the doors, push the front side of the switch.

To unlock the doors, push the rear side of the switch.

When you close the doors after you set the door locks, the doors remain locked.

**NOTE**

Make sure that you do not leave the key inside the vehicle before locking the doors from the outside using the power door locking switches.

**■ Key lock-in prevention function**

This function prevents the doors from being locked under the following conditions.

- The key is still in the ignition switch (models without “keyless access with push-button start system”).
- The ignition switch is in the “ON” position (models with “keyless access with push-button start system”).

This function’s operational/non-operational setting can be changed by a SUBARU dealer. Contact a SUBARU dealer for details.

**NOTE**

- **The factory setting (default setting) for this function is set as “operational”.**
- **When leaving the vehicle, make sure you are holding the key before locking the doors.**
- **When getting out of the vehicle from a rear door, make sure to unlock all the**

doors by pushing the unlock side of the power door locking switch.

If a rear door is unlocked from the inside door lever then the door is opened and closed, the Key lock-in prevention function will be triggered. All doors will be unlocked, the Key lock-in prevention warning indicator “**▼ Behavior with key lock-in prevention function operational**

With the driver’s door open, the doors are automatically kept unlocked even if the front side of the power door locking switch is pressed.

**▼ Behavior with key lock-in prevention function non-operational**

- If the lock lever is turned to the front (“LOCK”) position with the driver’s door open and the driver’s door is then closed with the lock lever in that position, the driver’s door is locked.
- If the spare key is used to lock the driver’s door from the outside of the vehicle, the door is locked.

**Keyless access with push-button start system (if equipped)**

You can perform the following operations using “keyless access with push-button start system” when you are holding the access key fob.

- Locking and unlocking of the doors
- Opening the trunk
- Starting and stopping the engine. For details, refer to “Models with push-button start systems” [☞ 7-11](#).
- Arming and disarming the alarm system. For details, refer to “Alarm system” [☞ 2-24](#).

**■ Safety precautions****▼ Regarding radio wave****WARNING**

**If you wear an implanted pacemaker or an implanted defibrillator, stay at least 8.7 in (22 cm) away from the transmitting antennas installed on the vehicle.**

**The radio waves from the transmitting antennas on the vehicle could adversely affect the operation of**

implanted pacemakers and implanted defibrillators.

If you wear electric medical equipment other than an implanted pacemaker or an implanted defibrillator, before using the keyless access with push-button start system, refer to “Radio waves used for the keyless access with push-button start system” 2-9, and contact the electric medical equipment manufacturer for more information. The radio waves from the transmitting antennas on the vehicle could adversely affect the operation of the electric medical equipment.

## NOTE

The status of the access key fob and environmental conditions may interfere with the communication between the access key fob and the vehicle under the following conditions.

- When you operate near a source of strong radio waves or other interference, such as a broadcast station or power transmission lines
- When products that transmit radio waves are used, such as an access key fob or a remote transmitter key fob of another vehicle

- When you carry the access key fob of your vehicle together with an access key fob or a remote transmitter of another vehicle
- When the access key fob is placed near wireless communication equipment such as a cell phone, or near a metallic object
- When metallic accessories are attached to the access key fob
- When you carry the access key fob with electronic appliances such as a laptop computer
- When the battery of the access key fob is discharged

In such cases, it may not be possible to lock or unlock the doors or start the engine.

### ▼ Regarding malfunction



## CAUTION

- Never leave or store the access key fob inside the vehicle or within 6.6 ft (2 m) around the vehicle (e.g., in the garage). The access key fob may be locked inside the vehicle, or the battery may discharge rapidly. Note that the push-button ignition switch may not turn on in some cases

depending on the location of the access key fob.

- The access key fob contains electronic components. Observe the following precautions to prevent malfunctions or battery discharge.
  - It is recommended that the battery be replaced by a SUBARU dealer to avoid the damage at the time of replacement.
  - Do not get the access key fob wet. If the access key fob gets wet, wipe it off immediately and let it dry completely.
  - Do not apply strong impacts to the access key fob.
  - Never leave the access key fob in direct sunlight or anywhere that may become hot, such as on the dashboard.
  - Do not wash the access key fob in an ultrasonic washer.
  - Do not leave the access key fob in humid or dusty locations, or near personal computers or home electric appliances.
  - Keep the access key fob away



from magnetic sources.

- Do not leave the access key fob near a battery charger or any electrical accessories.
- Do not apply metallic window tint or attach metallic objects to the windows.
- Do not fit non genuine accessories or parts.

## NOTE

● After the vehicle battery is discharged or replaced, initialization of the steering lock system may be required to start the engine. In this case, perform the following procedure to initialize the steering lock.

- 1) Turn the push-button ignition switch to the "OFF" position. For details, refer to "Switching power status" ☞ 3-7.
- 2) Open and close the driver's door.
- 3) Wait for approximately 10 seconds.

When the steering is locked, the initialization is completed.

- Do not leave the access key fob in the following places.
  - On the instrument panel
  - On the floor

- Inside the glove box
- Inside the door trim pocket
- On the rear seat
- On the rear shelf
- Inside the trunk

If you do, the following situations may occur.

- The access key fob is mistakenly locked inside the vehicle.
- A false warning issues although no malfunction actually occurs.
- No warning issues even when any malfunction occurs.

## ▼ Regarding setting

### NOTE

- You can change the operational/non-operational setting for the keyless access function. For the setting procedure, refer to "Disabling keyless access function" ☞ 2-14.
- For detailed information about the operation method for the push-button ignition switch while the keyless access function is switched to the non-operational mode, refer to "Access key fob – if access key fob does not operate properly" ☞ 9-18.

## ▼ Radio waves used for the keyless access with push-button start system

The keyless access with push-button start system uses radio waves of 134 kHz, in addition to the radio waves used for the remote keyless entry system. The radio waves are periodically output from the antennas installed on the vehicle as shown in the following illustration.

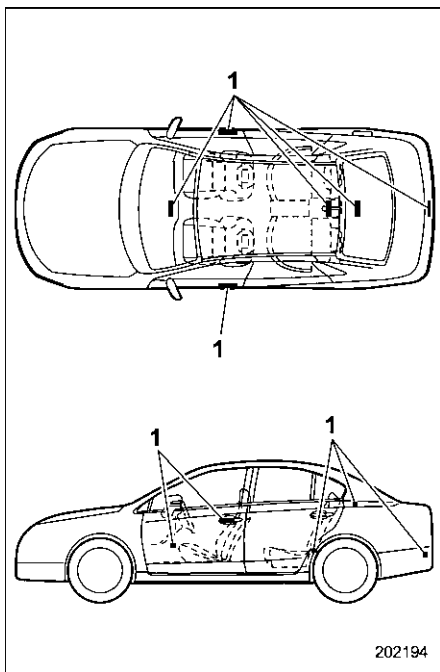

1) Antennas

### ■ Locking and unlocking by holding the access key fob

With the access key fob carried within the operating range, you can lock/unlock the doors just by touching the door handle.

### NOTE

You can lock/unlock the vehicle with the remote keyless entry system. For details, refer to "Remote keyless entry system" 2-18.

### ▼ Operating ranges

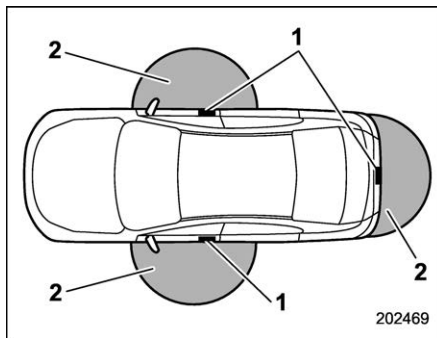

- 1) Antennas
- 2) Operating ranges

The operating ranges of the door locking/unlocking functions and the trunk lid opening function are approximately 16 to 32 in (40 to 80 cm) from the respective door

handles and the trunk ornament.

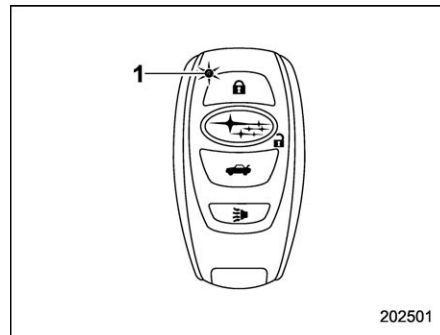

- 1) LED indicator

When the access key fob is within either of the operating ranges of the front doors, the LED indicator on the access key fob flashes. When the keyless access functions are disabled, the LED indicator does not flash unless a button on the access key fob is pressed.

▼ How to lock and unlock

▽ Unlocking

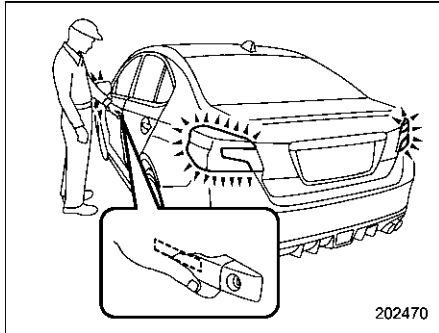

Carry the access key fob, and grip the door handle.

- When the driver's door handle is gripped, only the driver's door will be unlocked.
- When the front passenger's door handle is gripped, all doors will be unlocked.

Also, an electronic chirp will sound twice and the hazard warning flashers will flash twice.

▽ Opening trunk

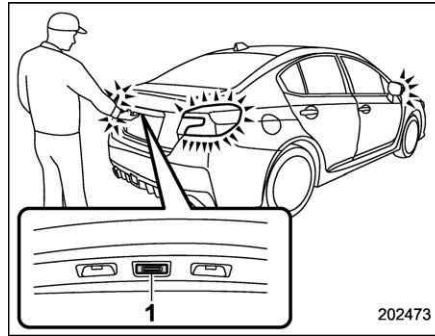

- 1) Trunk opener button

Carry the access key fob, and press the trunk opener button. The trunk will open. An electronic chirp will sound twice and the hazard warning flashers will flash twice.

**NOTE**

**Under the following conditions, the trunk can be opened without the key fob.**

- The trunk lock/unlock setting is set to on.
- All doors are unlocked.

The trunk lock/unlock setting can be changed by a SUBARU dealer. Contact your SUBARU dealer to change the setting.

▽ Locking

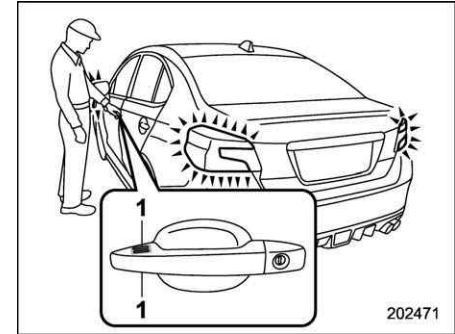

- 1) Door lock sensor (above and below)

Carry the access key fob, close all doors and the trunk lid and touch the door lock sensor on the door handle.

- All doors will be locked.
- An electronic chirp will sound once and the hazard warning flashers will flash once.

### NOTE

After touching the door lock sensor to lock all of the doors, if you touch the door lock sensor once more to attempt the lock operation without first unlocking the doors, nothing will happen, even if the door lock sensor is touched. In this case, perform the unlocking operation once first. You can then touch the door lock sensor to lock the doors.

### ▼ Door unlock selection function

You can unlock only the door(s) that has/have been selected.

You can change the setting as follows.

- Operate the multi-function display (color LCD). For details, refer to “Keyless Access Settings” 3-62.
- Have the setting changed by a SUBARU dealer.

### ■ Unlock using PIN Code Access

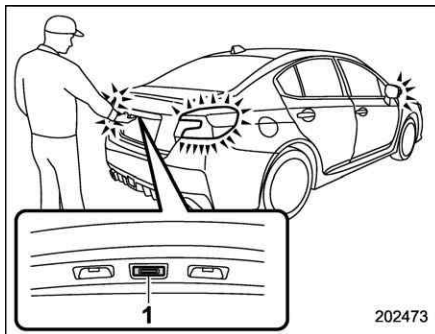

- 1) Trunk opener button

While all doors are locked, you can unlock the doors without a key by operating the trunk opener button.

### NOTE

**PIN Code Access will be helpful if the key is accidentally left in the vehicle. It is recommended that a 5-digit security code (PIN code) is registered.**

### ▼ Preparation for registering a PIN code

1. Close all doors (including the trunk).
2. Press and hold the “” button on the access key fob. Then all doors (including

the trunk) will be locked.

3. Keep the “” button pressed, and press the trunk opener button within 5 seconds after step 2.

4. Press and hold the trunk opener button for more than 5 seconds. Then a chirp will sound.

5. Press the “” button on the access key fob while the chirp sounds. Then the chirp will stop and the preparation is complete.

### NOTE

**If you do not press the “” button on the access key fob, the chirp will sound for 30 seconds. In this case, the preparation for registering a PIN code does not complete even if the chirp stops.**

### ▼ Registration for a PIN code

For example, to register “32468” as the PIN code, perform the following procedure.

1. Press the trunk opener button three times.
2. After a buzzer (ding) sounds once, press the trunk opener button twice.
3. After a buzzer (ding) sounds once, press the trunk opener button four times.
4. After a buzzer (ding) sounds once, press the trunk opener button six times.

5. After a buzzer (ding) sounds once, press the trunk opener button eight times.
6. Perform steps 1 to 5 again within approximately 30 seconds after the buzzer starts sounding intermittently.
7. All doors will be unlocked and locked. Then the PIN code will be registered.

## NOTE

- If you make an error during the registration procedure, open the driver's door and then close it. Then, start over from the procedure described in "Preparation".
- To protect your vehicle from theft, you cannot register "00000", "11111" to "99999" or "12345" as a PIN code.
- Do not register your vehicle license plate number or simple numbers such as "11122" or "12121" as a PIN code. Doing so will increase the risk of vehicle theft.
- When you try to register "22222", the registered PIN code will be deleted. You cannot unlock the doors by PIN Code Access until a new code is registered.
- After registering a new PIN code, make sure that you can unlock the doors using the PIN code.
- When you delete the PIN code while the keyless access function is disabled, the keyless access function will

be enabled.

- Reregister the PIN code in the following case.
  - When you forget the PIN code.
  - When you want to change the PIN code.

## ▼ Unlocking

Perform steps 1 to 5 described in "Registration".

## NOTE

- You cannot unlock by PIN Code Access in the following cases.
  - The access key fob is within the operating ranges.
  - The ignition switch is in the "ACC" or "ON" position.
- If you make an operation error during the unlocking procedure, start over with the unlocking procedure after waiting for 5 seconds or longer.
- To protect your vehicle from theft, a buzzer will sound if incorrect PIN codes are entered five times continuously. If this occurs, you cannot unlock the doors by PIN Code Access for 5 minutes.

## ■ Power saving function

The keyless access function will be disabled in the following cases to protect the battery of the access key fob and the vehicle battery.

**Case 1:** When the keyless access function and the remote keyless entry system have not been used for 2 weeks or longer while all doors are locked.

**Case 2:** When the access key fob has been left in the operating range for 10 minutes or longer while all doors are locked.

## ▼ Recovery from power saving mode

When one of the following is operated, the keyless access function will be recovered.

### Case 1:

- Unlock the doors by operating any procedure other than gripping the front passenger's door handle.
- Lock or unlock the doors.
- Open a door and then close it.

### Case 2:

- Unlock the doors by gripping the door handle.
- Lock the doors by touching the door lock sensor.

- Lock or unlock the doors by using the remote keyless entry system.
- Lock or unlock the doors by using the power door locking switch.
- Open either of the front doors.

### ■ Selecting audible signal operation

Using an electronic chirp, the system will give you an audible signal when the doors lock and unlock. If desired, you may change the volume of the audible signal or turn it off. For details, refer to “Keyless buzzer volume setting” 3-61.

### ■ Warning chimes and warning indicator

The warning chime and the access key warning light serve the following purposes:

- To minimize improper operation of the keyless access with push-button start system
- To protect your vehicle from theft

For details, refer to “Warning chimes and warning indicator of the keyless access with push-button start system” 3-28.

### ■ Disabling keyless access function

#### ⚠ WARNING

**If you wear an implanted pacemaker or an implanted defibrillator, operate the driver's door to disable the keyless access function. Otherwise, the operation of an implanted pacemaker or implanted defibrillator may be affected by the radio waves from the transmitter antenna.**

When the vehicle is not going to be used for a long time, or when you choose not to use the keyless access function, the keyless access function can be disabled.

#### NOTE

- **The locking and unlocking function by the remote keyless entry system is not disabled.**
- **To start the engine while the functions are disabled, perform the procedure described in “Starting engine” 9-19.**
- **We recommend that you disable the keyless access functions under the following conditions.**
  - **The vehicle is not going to be used for an extended period of time.**

- **The keyless access functions are not going to be used.**

#### ▼ Disabling functions

##### ▽ By operating the access key fob

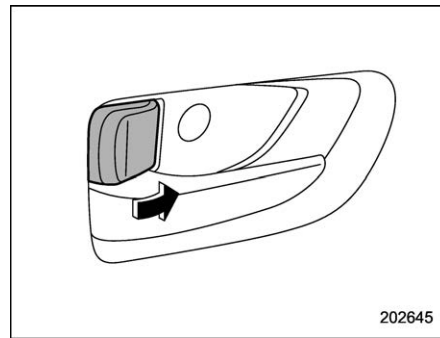

If you have registered a PIN code for PIN Code Access, you can disable the keyless access function by operating the access key fob. For details about registering a PIN code, refer to “Registration for a PIN code” 2-12.

1. Open the driver's door.

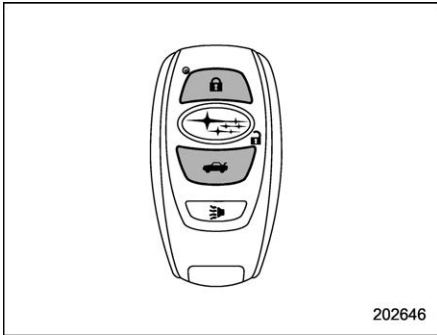

2. Rotate the lock lever forward.



3. Press and hold the “” button and “” button on the access key fob simultaneously for more than 5 seconds.

A chirp sound will be heard, and the function will be disabled.

▽ **By operating the driver’s door**

1. Sit in the driver’s seat, and close the door.

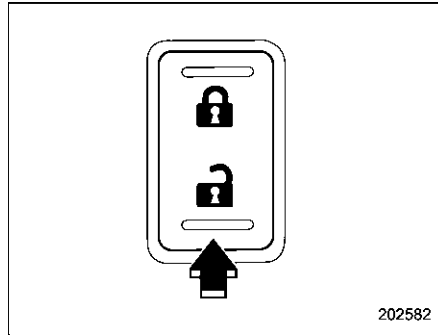

2. Push the rear side (unlock side) of the power door locking switch.
3. Within 5 seconds after step 2 is performed, open the driver’s door.
4. Within 5 seconds after step 3 is performed, push the rear side (unlock side) of the power door locking switch twice while the door is open.
5. Within 10 seconds after step 4 is performed, close and open the driver’s door twice.
6. Within 10 seconds after step 5 is performed, push the rear side (unlock side) of the power door locking switch twice while the door is open.
7. Within 10 seconds after step 6 is performed, close and open the driver’s door once.

8. Within 5 seconds after step 7 is performed, close the door. A chirp sound will be heard, and the functions will be disabled.

**NOTE**

**In steps 4 and 6, press the power door locking switch slowly. If the switch is pressed quickly, the functions may not be disabled.**

▼ **Enabling functions**

When the procedure to disable the functions is performed again, the functions are enabled.

**NOTE**

- **The keyless access function will be enabled only if you perform the procedure in the same manner you disabled the function (for example, when disabling by operating the driver’s door, the function will not be enabled even if you operate the access key fob).**

● Press the push-button ignition switch if you do not know the procedure in which the keyless access function was disabled.

– When disabling by operating the driver's door: A chirp will not be heard.

– When disabling by operating the access key fob: A chirp will be heard.

### ■ When access key fob does not operate properly

Refer to "Access key fob – if access key fob does not operate properly" 9-18.

### ■ Replacing battery of access key fob

Refer to "Replacing battery of access key fob" 11-52.

### ■ Replacing access key fob

Access key fobs can be replaced at SUBARU dealers. For more details, contact a SUBARU dealer.

## ■ Certification for keyless access with push-button start system

### ▼ U.S.-spec. models

FCC ID: HYQ14AHK

FCC ID: Y8PFJ17-1

FCC ID: Y8PSSPIMB02



### CAUTION

#### FCC WARNING

Changes or modifications not expressly approved by the party responsible for compliance could void the user's authority to operate the equipment.

### NOTE

This device complies with part 15 of the FCC Rules. Operation is subject to the following two conditions: (1) This device may not cause harmful interference, and (2) this device must accept any interference received, including interference that may cause undesired operation.

### ▼ Canada-spec. models

#### NOTE

This device complies with Industry Canada's licence-exempt RSSs. Operation is subject to the following two conditions: (1) This device may not cause interference; and (2) This device must accept any interference, including interference that may cause undesired operation of the device.

#### REMARQUE

Le présent appareil est conforme aux CNR d'Industrie Canada applicables aux appareils radio exempts de licence. L'exploitation est autorisée aux deux conditions suivantes: (1) l'appareil ne doit pas produire de brouillage; (2) l'utilisateur de l'appareil doit accepter tout brouillage radioélectrique subi, même si le brouillage est susceptible d'en compromettre le fonctionnement.



**▼ Mexico-spec. models**

Este equipo opera a título secundario, consecuentemente, debe aceptar interferencias perjudiciales incluyendo equipos de la misma clase y puede no causar interferencias a sistemas operando a título primario.

500612

IFT  
RLVDE1415-1661  
14AHK  
DENSO

**■ Tips****▼ Operating range tips****Regarding malfunction:**

The keyless access function may not operate properly due to the following reasons.

- The access key fob is placed too close to the vehicle body (in this case, repeat the operation from further away).
- The access key fob is placed near the ground or in an elevated location from the

ground, even if it is in the operating range.

- The status of the access key fob and the radio wave conditions around the vehicle (in this case, perform the procedure described in “Locking and unlocking” ☞9-18.)

**Precautions:**

- When the access key fob is within the operating range, it is possible for anyone, even someone who is not carrying the access key fob, to operate the keyless access function. Please note that the keyless access function is only available for the following items when the access key fob is detected within operating range.
  - Door handle
  - Door lock sensor
  - Trunk opener button
- It is not possible to lock the doors using the keyless access function when the access key fob is inside the vehicle. However, depending on the status of the access key fob and the environmental conditions, the access key fob may be locked inside the vehicle. Before locking, make sure that you have the access key fob.
- The operating ranges may be reduced, or the keyless access function may not operate in the following cases:
  - When the battery of the access key

fob is discharged

- When the access key fob is in a location with strong radio waves or noise (e.g., near a radio tower, power plant, broadcast station or an area where wireless equipment is used)
- While talking on a cell phone

In such a case, perform the procedure described in “Locking and unlocking” ☞9-18.

- When an access key fob is in the operating range, if the door handle becomes wet due to exposure to a significant amount of water when the vehicle is washed or during heavy rain, the doors may be locked or unlocked.

**▼ Keyless access function tips**

- Turn off the push-button ignition switch before locking the doors using the keyless access function. It is not possible to lock the doors using the keyless access function when the push-button ignition switch is on the “ACC” or “ON” position. For details about turning off the push-button ignition switch, refer to “Switching power status” ☞3-7.
- If the door handle is gripped or the door lock sensor is touched with a gloved hand, the doors may not be locked or unlocked.
- If the door lock sensor is touched three times or more repeatedly, the system will

ignore the sensor operation.

- When performing the locking procedure too quickly, doors may not be locked. After the locking procedures, it is recommended to pull the REAR door handles to confirm that the doors have been locked.
- It is possible to lock the doors even when one of the doors is open. After performing the locking procedure, close the opened door to lock it.
- Within 3 seconds after locking the doors by touching the door lock sensor, it is not possible to unlock doors by gripping the door handle.
- When locking, be sure to carry the access key fob to prevent locking the access key fob in the vehicle.
- The settings of the hazard warning flasher operation and the volume of the audible signal can be changed by your SUBARU dealer. Contact your SUBARU dealer for details. You can also change the setting of the hazard warning flasher operation by operating the multi-function display (color LCD). For details, refer to "Hazard warning flasher setting" 3-61.

### Remote keyless entry system

#### CAUTION

- **Do not expose the remote transmitter to severe shocks, such as those experienced as a result of dropping or throwing.**
- **Do not take the remote transmitter apart except when replacing the battery.**
- **Do not get the remote transmitter wet. If it gets wet, wipe it dry with a cloth immediately.**
- **When you carry the remote transmitter on an airplane, do not press the button of the remote transmitter while in the airplane. When any button of the remote transmitter is pressed, radio waves are sent and may affect the operation of the airplane. When you carry the remote transmitter in a bag on an airplane, take measures to prevent the buttons of the remote transmitter from being pressed.**

For models with "keyless access with push-button start system", the access key fob is used as the transmitter for the

remote keyless entry system. For models without "keyless access with push-button start system", the transmitter for the remote keyless entry system is located inside the key head.

The remote keyless entry system has the following functions.

- Locking and unlocking the doors without a key
- Opening the trunk without a key
- Sounding a panic alarm
- Arming and disarming the alarm system. For detailed information, refer to "Alarm system" 2-24.

The operable distance of the remote keyless entry system is approximately 30 feet (10 meters). However, this distance will vary depending on environmental conditions. The system's operable distance will be shorter in areas near a facility or electronic equipment emitting strong radio waves such as a power plant, broadcast station, TV tower, or remote controller of home electronic appliances.

#### NOTE

- For models with "keyless access with push-button start system", the remote keyless entry system will not be activated when the push-button ignition switch is in any position other

than the “OFF” position.

● For models without “keyless access with push-button start system”, the remote keyless entry system will not be activated when the key is inserted in the ignition switch.

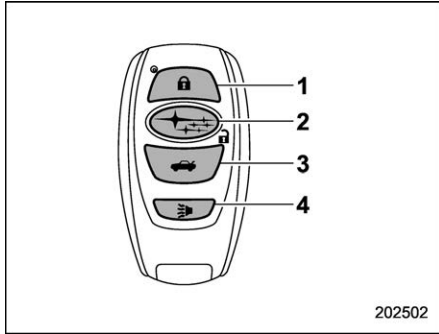

**Access key fob**

- 1) Lock/arm button
- 2) Unlock/disarm button
- 3) Trunk opener button
- 4) PANIC button

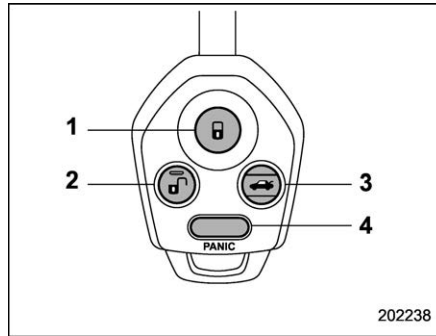

**Transmitter**

- 1) Lock/arm button
- 2) Unlock/disarm button
- 3) Trunk opener button
- 4) PANIC button

**NOTE**

The hazard warning flashers will flash once or twice when the transmitter button is pressed in the following cases.

- When locking the doors
- When unlocking the doors
- When unlocking the trunk lid

Operation of the hazard warning flashers in the above cases can be set to “On” or “Off” by a SUBARU dealer. Consult your SUBARU dealer for de-

tails. Also, you can change the setting using the multi-function display (color LCD). For details, refer to “Hazard warning flasher setting” 3-61.

**Locking the doors**

Press the lock/arm button to lock all doors. An electronic chirp will sound once and the hazard warning flashers will flash once.

If any of the doors or the trunk lid is not fully closed, an electronic chirp will sound five times and the hazard warning flashers will flash five times to alert you that the doors (or the trunk lid) are not properly closed. When you close the door, it will automatically lock and then an electronic chirp will sound once and the hazard warning flashers will flash once.

**Unlocking the doors**

Press the unlock/disarm button to unlock the driver’s door. An electronic chirp will sound twice and the hazard warning flashers will flash twice. To unlock all doors, briefly press the unlock/disarm button a second time within 5 seconds.

## NOTE

If the interval between the first and second presses of the unlock/disarm button (for unlocking of all of the doors) is extremely short, the system may not respond.

## ■ Opening the trunk lid

The trunk lid opens when the “” button is pressed continuously for at least 2 seconds. An electronic chirp will sound twice and the turn signal lights will flash twice.

## NOTE

**You can disable the “” button on the access key fob/transmitter. Contact your SUBARU dealer to change the setting.**

## ■ Vehicle finder function

Use this function to find your vehicle parked among many vehicles in a large parking lot. Provided you are within 30 feet (10 meters) of the vehicle, pressing the lock/arm button three times in a 5-second period will cause your vehicle's horn to sound once and its hazard warning flashers to flash three times.

## NOTE

If the interval between presses is too short when you press the lock/arm button three times, the system may not respond to the signals from the access key fob/remote transmitter.

## ■ Sounding a panic alarm

To activate the alarm, press the “PANIC” button once.

The horn will sound and the hazard warning flashers will flash.

To deactivate the panic alarm, press any button on the access key fob/remote transmitter. Unless a button on the access key fob/remote transmitter is pressed, the alarm will be deactivated after approximately 30 seconds.

## ■ Selecting audible signal operation (models without “keyless access with push-button start system”)

Using an electronic chirp, the system will give you an audible signal when the doors lock and unlock. If desired, you may turn the audible signal off.

Perform the following steps to deactivate the audible signal. You can also use the

same steps to restore the function.

1. Sit in the driver's seat and shut all doors and the trunk.

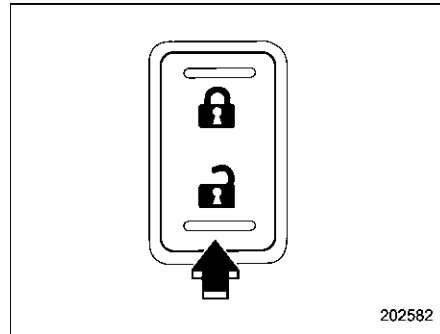

2. Hold down the REAR (UNLOCK) side of the power door locking switch.
3. While holding down the REAR (UNLOCK) side of the power door locking switch, pull the key out and re-insert it into the ignition switch at least 6 times within 10 seconds after Step 2.
4. Open and close the driver's door once within 10 seconds after Step 3.
5. The hazard warning flashers flash 3 times to indicate completion of the setting.

You may have the above settings done by your SUBARU dealer. Also, the setting can be changed using the multi-function display (color LCD). For details, refer to

“Keyless buzzer volume setting” 3-61.

You may also change the volume of the audible signal by operating the multi-function display (color LCD).

## ■ Replacing the battery

Refer to “Replacing battery” 11-52.

## ■ Replacing lost transmitters

If you lose a transmitter or want to purchase additional transmitters (up to four can be programmed), your transmitters should be reprogrammed for security reasons. For details, contact your SUBARU dealer and have the transmitters programmed into the remote keyless entry system.

## ■ Certification for Remote keyless entry system

### ▼ U.S.-spec. models

FCC ID: CWTWB1U811

FCC ID: CWTWD1U781



**CAUTION**

### FCC CAUTION

Changes or modifications not expressly approved by the party responsible for compliance could void the user's authority to operate the equipment.

### NOTE

This device complies with part 15 of the FCC Rules. Operation is subject to the following two conditions: (1) This device may not cause harmful interference, and (2) this device must accept any interference received, including interference that may cause undesired operation.

### ▼ Canada-spec. models

### NOTE

This device complies with Industry Canada's licence-exempt RSSs. Operation is subject to the following two conditions: (1) This device may not cause interference; and (2) This device must accept any interference, including interference that may cause undesired operation of the device.

### REMARQUE

Le présent appareil est conforme aux CNR d'Industrie Canada applicables aux appareils radio exempts de licence. L'exploitation est autorisée aux deux conditions suivantes: (1) l'appareil ne doit pas produire de brouillage; (2) l'utilisateur de l'appareil doit accepter tout brouillage radioélectrique subi, même si le brouillage est susceptible d'en compromettre le fonctionnement.

203161

### ▼ Mexico-spec. models

La operación de este equipo está sujeta a las siguientes dos condiciones:

- (1) es posible que este equipo o dispositivo no cause interferencia perjudicial y
- (2) este equipo o dispositivo debe aceptar cualquier interferencia, incluyendo la que pueda causar su operación no deseada.

202642

COFETEL RCPSUTW13-2221  
COFETEL RLVSU8813-2140

## Anti-theft system

### ■ Immobilizer

The immobilizer system is designed to prevent an unauthorized person from starting the engine. Only keys registered with your vehicle's immobilizer system can be used to operate your vehicle. This system, however, is not a 100% anti-theft guaranty.

#### For models with “keyless access with push-button start system”:

If you press the push-button ignition switch when carrying an unregistered access key fob, the switch will not turn to the “ON” position and the engine will not start.

#### For models without “keyless access with push-button start system”:

Even if an unregistered key fits into the ignition switch and can be turned to the “START” position, the engine will automatically stop after several seconds.

If the engine does not start, perform either of the following procedures.

- Perform the procedure described in “Starting engine” ¶9-19 (models with “keyless access with push-button start system”).
- Pull out the key once before trying again (models without “keyless access

with push-button start system”). Refer to “Ignition switch” ¶3-4.



### CAUTION

- Do not place the key under direct sunlight or anywhere it may become hot.
- Do not get the key wet. If the key gets wet, wipe it dry with a cloth immediately.
- Do not modify or remove the system. If modified or removed, the proper operation of the system cannot be guaranteed.

### NOTE

- To protect your vehicle from theft, please pay close attention to the following security precautions:
  - Never leave your vehicle unattended with its keys inside.
  - Before leaving your vehicle, close all windows and the moonroof, and lock the doors.
  - Do not leave spare keys or any record of your key number in the vehicle.
- The vehicle has a maintenance-free type immobilizer system.

**▼ Security indicator light**

Refer to “Security indicator light” 3-33.

**▼ Key replacement**

Your key number plate will be required if you ever need a replacement key made. Any new key must be registered for use with your vehicle’s immobilizer system before it can be used. The maximum number of keys that can be registered for use with one vehicle is as follows.

- Four (models without “keyless access with push-button start system”)
- Seven (models with “keyless access with push-button start system”)

One key that has already been registered is required in order to register a new key.

If you lose a key, the lost key’s ID code still remains in the memory of the vehicle’s immobilizer system. For security reasons, the lost key’s ID code should be erased from the memory. To erase the lost key’s ID code, all keys that will be used are required.

For details about new key registration and erasing the lost key’s ID code, contact your SUBARU dealer.

**▼ Certification for immobilizer system**

**For models with “keyless access with push-button start system”:**

Refer to “Certification for keyless access with push-button start system” 2-16.

**For models without “keyless access with push-button start system”:**

**▼ U.S.-spec. models**

FCC ID: MOZRI-38BFH

**CAUTION****FCC WARNING**

**Changes or modifications not expressly approved by the party responsible for compliance could void the user’s authority to operate the equipment.**

This device complies with part 15 of the FCC Rules. Operation is subject to the following two conditions: (1) This device may not cause harmful interference, and (2) this device must accept any interference received, including interference that may cause undesired operation.

**▼ Canada-spec. models****NOTE**

**This device complies with Industry Canada’s licence-exempt RSSs. Operation is subject to the following two conditions: (1) This device may not cause interference; and (2) This device must accept any interference, including interference that may cause undesired operation of the device.**

**REMARQUE**

**Le présent appareil est conforme aux CNR d’Industrie Canada applicables aux appareils radio exempts de licence. L’exploitation est autorisée aux deux conditions suivantes: (1) l’appareil ne doit pas produire de brouillage; (2) l’utilisateur de l’appareil doit accepter tout brouillage radioélectrique subi, même si le brouillage est susceptible d’en compromettre le fonctionnement.**

203161

### ▽ Mexico-spec. models

Este equipo opera a título secundario, consecuentemente, debe aceptar interferencias perjudiciales incluyendo equipos de la misma clase y puede no causar interferencias a sistemas operando a título primario.

500612

### ■ Alarm system

The alarm system helps to protect your vehicle and valuables from theft. The horn sounds and the hazard warning flashers flash if someone attempts to break into your vehicle.

#### **For models with “keyless access with push-button start system”:**

You can arm or disarm the system with the keyless access function or access key fob. The system will not be activated when the push-button ignition switch is in the “ACC” or “ON” position.

#### **For models without “keyless access with push-button start system”:**

You can arm or disarm the system with the remote transmitter.

The system will not be activated when the key is inserted into the ignition switch.

Your vehicle’s alarm system has been set for activation at the time of shipment from the factory. You can set the system for deactivation yourself or have it done by your SUBARU dealer.

#### ▼ System operation

The alarm system will give the following alarms when triggered.

- The vehicle’s horn will sound for 30 seconds.
- The hazard warning flashers will flash for 30 seconds.

If any of the doors, trunk lid or engine hood remains open after the 30-second period, the horn will continue to sound for a maximum of 3 minutes. If the door, trunk lid or engine hood is closed while the horn is sounding, the horn will stop sounding with a delay of up to 30 seconds.

The alarm is triggered by:

- Opening any of the doors or the trunk lid
- Opening the engine hood

- Physical impact to the vehicle, such as forced entry (only models with shock sensors (dealer option))

### NOTE

**You can set the alarm system to trigger the illumination of the following interior lights.**

- **Map lights (for models with moonroof)**
- **Dome light (illuminates only when the dome light switch is in the “DOOR” position)**

**The notifications regarding the map lights (for models with moonroof) and dome light are deactivated as the factory setting. A SUBARU dealer can activate the system. Contact your SUBARU dealer for details.**

#### ▼ Activating and deactivating the alarm system

To change the setting of your vehicle’s alarm system for activation or deactivation, do the following.

1. Disarm the alarm system. Refer to “Disarming the system” 2-28.
2. Sit in the driver’s seat and shut all doors and the trunk lid.
3. Turn the ignition switch to the “ON” position.



4. Hold down the REAR (UNLOCK) side of the driver's power door locking switch, open the driver's door within the following 1 second, and wait 10 seconds without releasing the switch. The setting will then be changed as follows.

**If the system was previously activated:**

The odometer/trip meter screen displays "AL OF" and the horn sounds twice, indicating that the system is now deactivated.

**If the system was previously deactivated:**

The odometer/trip meter screen displays "AL ON" and the horn sounds once, indicating that the system is now activated.

**NOTE**

You may have the above setting change done by your SUBARU dealer.

▼ **If you have accidentally triggered the alarm system**

▽ **To stop the alarm**

Perform any of the following operations.

- Press any button on the access key fob/remote transmitter.
- Turn the ignition switch to the "ON" position (models without "keyless access with push-button start system").

- Turn the push-button ignition to the "ACC" position (models with "keyless access with push-button start system").

**NOTE**

Only registered keys will stop the alarm. If the key is not registered, the alarm will not stop.

▼ **Arming the system**

**NOTE**

- You can arm the system even if the windows and/or the moonroof are open. Always make sure that they are fully closed before arming the system.
- When arming the system, if any of the doors or the trunk lid is not fully closed, an electronic chirp sounds five times, the hazard warning flashers flash five times to alert you that the doors (or the trunk lid) are not properly closed. When you close the door, doors will automatically lock and the system will automatically arm in 30 seconds.
- The 30-second standby time can be eliminated if you prefer. Have it performed by your SUBARU dealer.
- If you open the trunk using the remote transmitter's "🚗" button in the surveillance state (or the standby state), the system will be temporarily placed in a standby state. The system

will go back to the surveillance state in 30 seconds upon locking the trunk.

- The system is in the standby state for a 30-second period before arming the system. The security indicator light will flash at short intervals during this period.

● If any of the following actions is done during the standby period, the system will not switch to the surveillance state.

- Doors are unlocked using the access key fob/remote transmitter.
- Doors are unlocked using the keyless access function (models with "keyless access with push-button start system").
- Any door is opened.
- The ignition switch is turned to the "ON" position (models without "keyless access with push-button start system").
- Push-button ignition switch is turned to the "ACC" position (models with "keyless access with push-button start system").

### ▽ To arm the system using the access key fob/remote transmitter

1. Close all windows and the moonroof (if equipped).
2. Remove the key from the ignition switch (models without “keyless access with push-button start system”)/turn the push-button ignition switch to the “OFF” position (models with “keyless access with push-button start system”).
3. Open the doors and get out of the vehicle.
4. Make sure that the engine hood is locked.
5. Close all doors and the trunk lid.

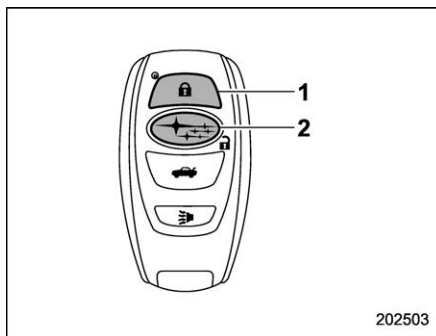

202503

#### Access key fob

- 1) Arm button: Press to arm the system
- 2) Disarm button: Press to disarm the system

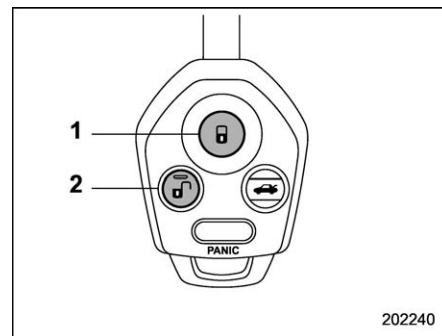

202240

#### Transmitter

- 1) Arm button: Press to arm the system
- 2) Disarm button: Press to disarm the system

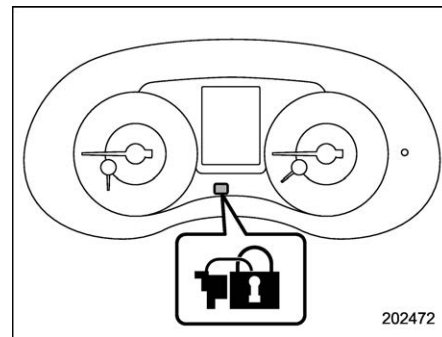

202472

6. Briefly press the arm button (for less than 2 seconds).

All doors will lock, an electronic chirp will sound once, the hazard warning flashers will flash once, and the security indicator light will start flashing rapidly.

After rapid flashing for 30 seconds (stand-by time), the indicator light will then flash slowly (twice approximately every 2 seconds), indicating that the system has been armed for surveillance.

▽ **To arm the system using power door locking switches**

1. Close all windows.
2. Remove the key from the ignition switch (models without “keyless access with push-button start system”)/turn the push-button ignition switch to the “OFF” position (models with “keyless access with push-button start system”).
3. Open the doors and get out of the vehicle.
4. Make sure that the engine hood is locked.
5. Close the doors and the trunk lid but leave only the driver’s door or the front passenger’s door open.

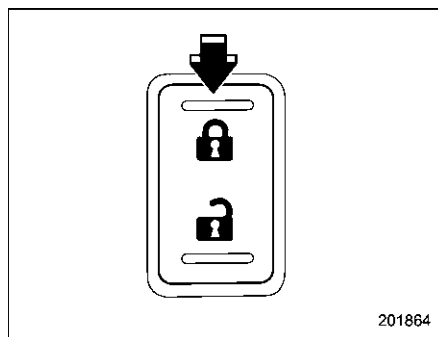

201864

6. Press the front side (“LOCK” side) of the power door locking switch to set the door locks.

7. Close the door.

An electronic chirp will sound once, the hazard warning flashers will flash once and the security indicator light will start flashing rapidly.

After rapid flashing for 30 seconds (stand-by time), the indicator light will then flash slowly (twice approximately every 2 seconds), indicating that the system has been armed for surveillance.

▽ **To arm the system using the keyless access function (if equipped)**

1. Close all windows and the moonroof (if equipped).
2. Turn the push-button ignition switch to the “OFF” position.
3. Open the doors and get out of the vehicle.
4. Make sure that the engine hood is locked.
5. Close all doors and the trunk lid.

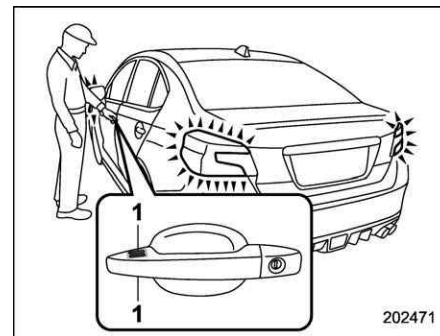

202471

- 1) Door lock sensor

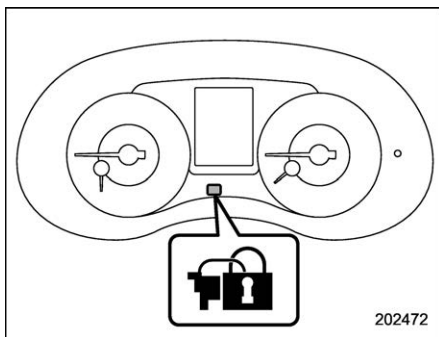

Security indicator light

6. Carry the access key fob and touch the door lock sensor.

All doors will lock, an electronic chirp will sound once, the hazard warning flashers will flash once, and the security indicator light will start flashing rapidly.

After rapid flashing for 30 seconds (stand-by time), the security indicator light will then flash slowly (twice approximately every 2 seconds), indicating that the system has been armed for surveillance.

### ▼ Disarming the system

Perform either of the following procedures.

- Briefly press the disarm button (for less than 2 seconds) on the access key fob/remote transmitter.
- Carry the access key fob and grip the front door handle (models with “keyless access with push-button start system”).

The flashing of the security indicator light will then change slowly (once approximately every 3 seconds from twice approximately every 2 seconds), indicating that the alarm system has been disarmed.

### ▼ Emergency disarming

If you cannot disarm the system using the access key fob/transmitter (i.e. the transmitter is lost, broken or the transmitter battery is too weak), you can disarm the system without using the access key fob/remote transmitter.

You can disarm the system if you turn the ignition switch from the “LOCK”/“OFF” to the “ON” position with a registered key/access key fob.

### NOTE

For models with “keyless access with push-button start system”, if the battery of the access key fob is discharged, perform the procedure de-

scribed in “Switching power status” 9-19. In such a case, replace the battery immediately. Refer to “Replacing battery of access key fob” 11-52.

### ▼ Valet mode

When you choose the valet mode, the alarm system does not operate. In valet mode, the access key fob/transmitter is used only for locking and unlocking the doors and for panic activation.

To enter the valet mode, change the setting of your vehicle’s alarm system for deactivation mode. Refer to “Activating and deactivating the alarm system” 2-24. The security indicator light will continue to flash once every 3 seconds indicating that the system is in the valet mode.

To exit valet mode, change the setting of your vehicle’s alarm system for activation mode. Refer to “Activating and deactivating the alarm system” 2-24.

### ▼ Passive arming (models without “keyless access with push-button start system”)

When passive arming mode has been programmed by the dealer, arming of the system is automatically accomplished without using the remote transmitter. Note that in this mode, **DOORS MUST BE MANUALLY LOCKED**.

#### ▽ To enter the passive mode

If you wish to program the passive arming mode, have it done by your SUBARU dealer.

#### ▽ Arming the system

### **CAUTION**

**In passive mode, the system will automatically activate the alarm but WILL NOT automatically lock the doors. In order to lock the doors you must either lock them as indicated in step 4 below or with the key once they have been closed. Failure to lock the doors manually will result in a higher security risk.**

1. Turn the ignition switch to the “ON” position.

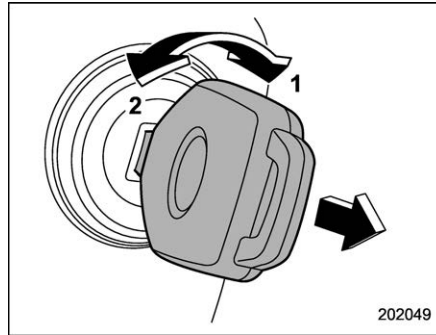

- 1) ON
- 2) LOCK

2. Turn the ignition switch from “ON” to “LOCK” position and remove the key from the ignition switch.
3. Open the doors and get out of the vehicle.

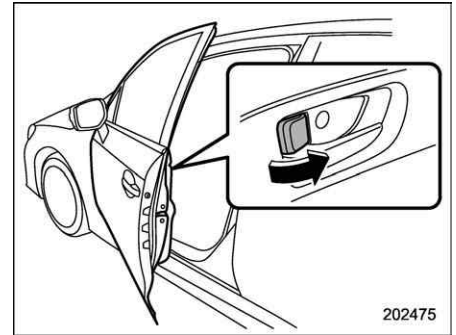

4. Before closing the doors, lock all doors with the inside door lock levers.
5. Close the doors. The system will automatically arm after 1 minute.

In the passive mode, you can also arm the system with the remote transmitter or with the power door locking switches. If you use the remote transmitter or power door locking switch to lock the vehicle, arming will take place immediately regardless of whether or not the passive mode has been selected.

#### ▽ Disarming the system

To disarm the system, briefly press the disarm button on the remote transmitter.

### ▼ Tripped sensor identification

The security indicator light flashes when the alarm system has been triggered. Also, the number of flashes indicates the location of unauthorized intrusion or the severity of impact on the vehicle.

After turning the ignition switch to the "ON" position, the indicator light will light for 1 second and then flash as follows.

- When a door was opened: 5 times
- When the trunk was opened: 4 times
- When the engine hood was opened: 3 times
- When a strong impact or multiple impacts were sensed: twice (only models with shock sensors (dealer option))
- When a light impact was sensed: once (only models with shock sensors (dealer option))

### NOTE

Any of the above indicator light flashings will recur each time the ignition switch is turned to the "ON" position. Rearming the alarm system cancels the flashing.

### ▼ Shock sensors (dealer option)

The shock sensors trigger the alarm system when they sense impacts applied to the vehicle and when any of their electric wires are cut. The alarm system causes the horn to sound and the hazard warning flashers to flash for a short time when the sensed impact is weak, but it warns of a strong impact or multiple impacts by sounding the horn and flashing the hazard warning flashers, both lasting approximately 30 seconds.

If you desire, your SUBARU dealer can connect them and set them for activation or deactivation.

### NOTE

- **The shock sensors are not always able to sense impacts caused by breaking in, and cannot sense an impact that does not cause vibration (such as breaking the glass using a rescue hammer).**
- **The shock sensors may sense vibration as indicated in the following examples and trigger the alarm system. Select the settings of the alarm system and shock sensors appropriately depending on where you usually park your vehicle.**

### Examples:

- Vibration from a construction site
- Vibration in a multistory car park
- Vibration from trains
- **You can have the sensitivity of the shock sensors adjusted to your preference by your SUBARU dealer.**

## Child safety locks

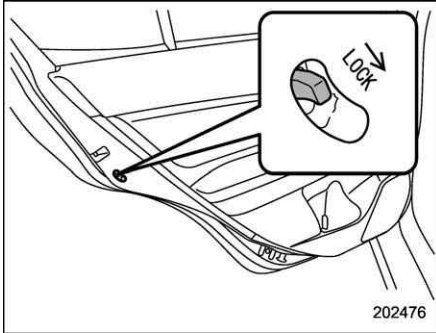

Each rear door has a child safety lock. When the child safety lock lever is in the lock position, the door cannot be opened from inside. The door can only be opened from the outside.

### WARNING

Always turn the child safety locks to the “LOCK” position when children sit in the rear seat. Serious injury could result if a child accidentally opens the door and falls out.

## Windows

### WARNING

To avoid serious personal injury caused by accidental, child’s mischief, or improper operation, the driver is responsible for obeying the following instructions without exception.

- When operating the power windows, be extremely careful to prevent anyone’s body parts or any other objects from being caught in the window.
- Always lock the passengers’ windows using the lock switch when children are riding in the vehicle.
- Always carry the key when you leave the vehicle for safety reasons and never allow an unattended child to remain in the vehicle. Failure to follow this procedure could result in injury to a child operating the power window.

## NOTE

If the vehicle battery is disconnected (e. g., the battery or fuse is replaced), the following functions will be deactivated.

- One-touch auto up/down function
- Anti-entrapment function

Initialize the power window to reactivate such functions. For details, refer to “Initialization of power window” 2-35.

## ■ Power window operation by driver

### ▼ Driver's side power window switches

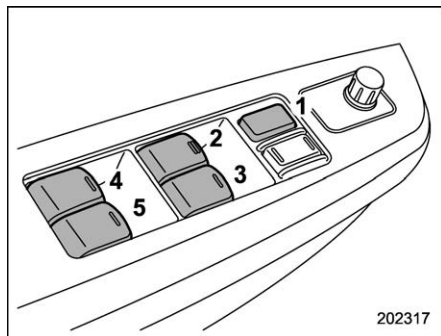

- 1) Lock switch
- 2) For driver's window (with one-touch auto up and down feature)
- 3) For front passenger's window (with one-touch auto up and down feature)
- 4) For rear left window
- 5) For rear right window

You can control all the door windows by the power window switch cluster at the driver side door.

### ▼ Operating the driver's/front passenger's window

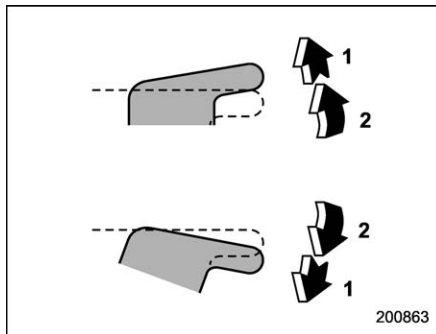

- 1) Automatically open/close
- 2) Open/close

#### To open:

Press the switch down lightly and hold it. The window will open as long as the switch is held.

Press the switch down until it clicks and release it, and the window will fully open. To stop the window halfway, pull the switch up lightly.

#### To close:

Pull the switch up lightly and hold it. The window will close as long as the switch is held.

Pull the switch up until it clicks and release it, and the window will fully close. To stop

the window halfway, press the switch down lightly.

### NOTE

When the following operations are performed, the power window breaker will operate and it may not be possible to open or close the window.

- After the driver's or front passenger's window is fully closed or fully opened, the switch is continuously operated in the same direction for a few seconds.
- After the windows for three or more seats are fully closed or fully opened, each switch is continuously operated in the same direction simultaneously for a few seconds.

**In this case, after the breaker recovers, be sure to initialize the power windows. If they are not initialized, the one-touch auto up/down function will not operate. Refer to "Initialization of power window" 2-35.**



### ▼ Anti-entrapment function



**CAUTION**

- Never attempt to test this function using fingers, hands or other parts of your body.
- The anti-entrapment function may not operate properly if some object gets trapped just before the window fully closes.

### NOTE

- If a window detects an impact similar to that caused by trapping an object (for example, when the vehicle encounters a deep pothole), the anti-entrapment function may operate.
- The window cannot be operated for a few seconds after the anti-entrapment function operates.

While closing the driver's or front passenger's window automatically, if the window senses a substantial enough object trapped between the window and the window frame, it automatically moves down slightly and stops.

### ▼ Operating the rear windows

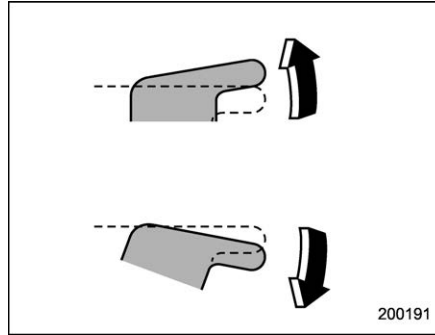

#### To open:

Press the appropriate switch down and hold it until the window reaches the desired position.

#### To close:

Pull the switch up and hold it until the window reaches the desired position.

### ▼ Locking the passengers' windows

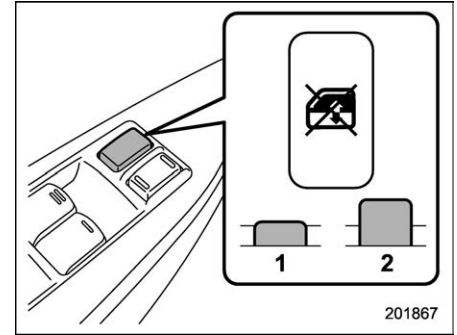

- 1) Lock
- 2) Unlock

#### To lock:

Press the lock switch. When the lock switch is in the lock position, the passengers' windows cannot be opened or closed.

#### To unlock:

Press the lock switch again.

## ■ Power window operation by passengers

### ▼ Passenger's side power window switches

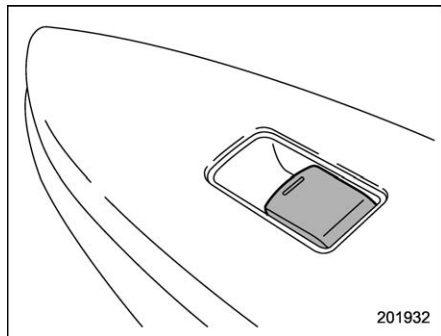

Each passenger window can be controlled by the power window switch located on the door.

### ▼ Operating the front passenger's window

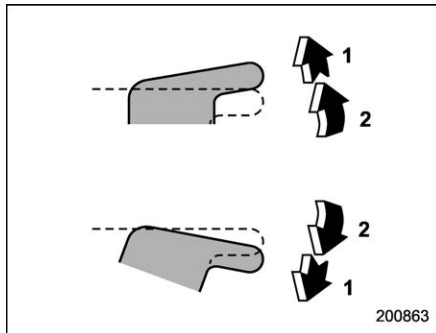

- 1) Automatically open/close
- 2) Open/close

#### To open:

Press the switch down lightly and hold it. The window will open as long as the switch is held.

Press the switch down until it clicks and release it, and the window will fully open. To stop the window halfway, pull the switch up lightly.

#### To close:

Pull the switch up lightly and hold it. The window will close as long as the switch is held.

Pull the switch up until it clicks and release it, and the window will fully close. To stop

the window halfway, press the switch down lightly.

#### ▼ Anti-entrapment function

Refer to "Anti-entrapment function" 2-33.

### ▼ Operating the rear passenger's windows

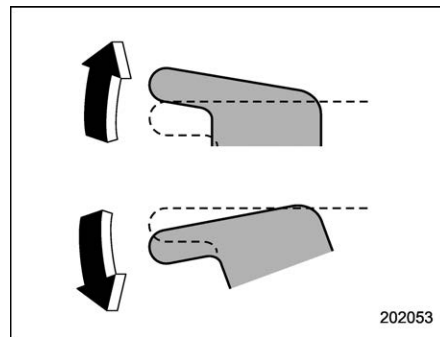

#### To open:

Press the switch down and hold it until the window reaches the desired position.

#### To close:

Pull the switch up and hold it until the window reaches the desired position.

When the lock switch on the power window switch cluster, located on the driver's side door, is in the lock position, the passengers' windows cannot be operated with the

passengers' switches.

### ■ Off delay function

You can operate the front windows for approximately 40 seconds even after turning the ignition switch from the "ON" position to the "ACC" or "OFF" position. If a front door is opened within 40 seconds, the off delay function is canceled.

### ■ Initialization of power window

If the vehicle's battery is disconnected due to situations such as battery or fuse replacement, the following functions will be deactivated.

- One-touch auto up/down function
- Anti-entrapment function

Initialize the driver's and front passenger's power window using the following procedure to reactivate these functions.

1. Close the door.
2. Turn the ignition switch to the "ON" position.
3. Open the window halfway by pressing down the power window switch.
4. Pull up the power window switch and close the window completely. Continue pulling up the switch for approximately 1 second after the window is closed completely.

5. Open the window completely by fully pressing down the power windows switch. It is necessary to repeat the same initialization procedure for both driver's and front passenger's window switches.

## Trunk lid



### WARNING

- To prevent dangerous exhaust gas from entering the vehicle, always keep the trunk lid closed while the engine is running.
- Check that the trunk is completely closed before driving. If it is not, it may suddenly open, which could lead to an accident.
- Help prevent children, adults or animals from locking themselves in the trunk. On hot or sunny days, the temperature in the trunk could quickly become high enough to cause death or serious heat-related injuries including brain damage to anyone locked inside, particularly for small children.
- When leaving the vehicle, close all windows and lock all doors. Also make certain that the trunk is closed.



### CAUTION

- Be extremely careful not to catch

fingers or other objects when closing the trunk lid.

- Check carefully when opening and closing the trunk.
- Pay attention to hot engine exhaust gas when loading and unloading cargo, as it could possibly cause burns.
- Be careful opening the trunk when the wind is strong. The trunk lid could close or open suddenly, possibly causing injuries.
- Make sure that the trunk is completely open when using it. If it is not, the trunk lid may suddenly drop and cause serious injury.
- Be careful opening and closing the trunk suddenly on a slope, as the trunk is more difficult to open and close on a slope than on a flat area.
- Do not install accessories other than genuine SUBARU parts. If the trunk lid becomes too heavy, the stay may not be able to hold it open.
- Remove snow and ice from the trunk lid before opening it. Not doing so could cause the trunk

lid to fall after it is opened.

- Do not push the trunk lid forcibly to close it. It could deform the metal.

### ■ To open and close the trunk lid from outside

To open the trunk lid from outside, use the keyless access function or remote keyless entry system. For details, refer to the following section.

- For models with “keyless access with push-button start system”, refer to “Opening trunk” 2-11.
- For models without “keyless access with push-button start system”, refer to “Opening the trunk” 2-20.

To close the trunk lid, lightly press the trunk lid down until the latch engages.

### NOTE

- Do not leave your valuables in the trunk when you leave your vehicle.
- You can disable the “” button on the access key fob/transmitter. Contact your SUBARU dealer to change the setting.

### ■ To open the trunk lid from inside

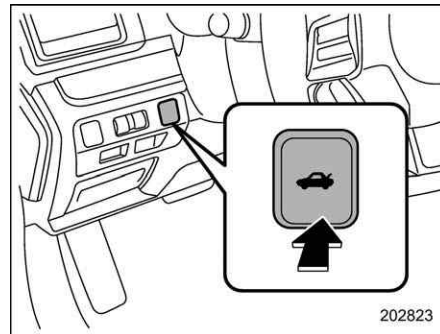

Trunk opener switch

Press the trunk opener switch for more than 1 second.

### NOTE

The trunk lid will not open when the select lever is in a position other than the “P” position (CVT models) or the vehicle is moving.

## ■ Internal trunk lid release handle

The internal trunk lid release handle is a device designed to open the trunk lid from inside the trunk. In the event children or adults become locked inside the trunk, the handle allows them to open the lid. The handle is located on the inside of the trunk lid.

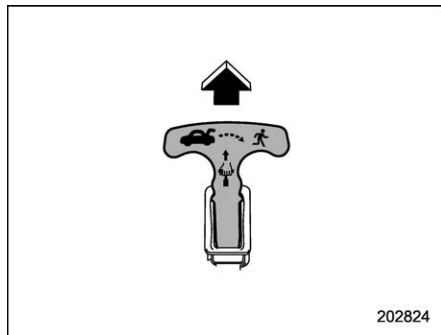

To open the trunk lid from inside the trunk, pull the yellow handle as indicated by the arrow on the handle. This operation unlocks the trunk lid. Then, push up the lid. The handle is made of material that remains luminescent for approximately an hour in the dark trunk space after it is exposed to ambient light even for a short time.

### ⚠ WARNING

**Never allow any child to get in the trunk and play with the release handle. If the driver starts the vehicle without knowing that a child is inside the trunk and the child opens the lid using the release handle, the child could fall out and be killed or seriously injured.**

### ⚠ CAUTION

- Do not close the lid while gripping the release handle. The handle may be damaged.
- Do not use the handle as a hook to fasten straps or ropes to secure your cargo in the trunk. Such use may result in damage of the handle.
- Load the trunk so that cargo cannot strike the release handle. If the cargo hits the handle while the vehicle is being driven, the handle may be pulled and the trunk lid may open. That may cause cargo to fall out of the trunk, which could create a traffic safety hazard.

### ▼ Inspection

Perform the following steps at least twice a year to check the release handle for correct operation.

1. Open the trunk lid.

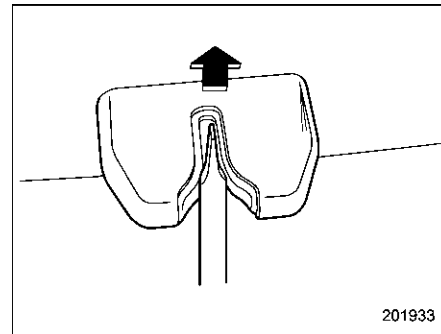

2. Use a flat-head screwdriver with a thin blade. Slide the flat-head screwdriver blade from the slit aperture of the lock assembly fully to the end until you hear a click.

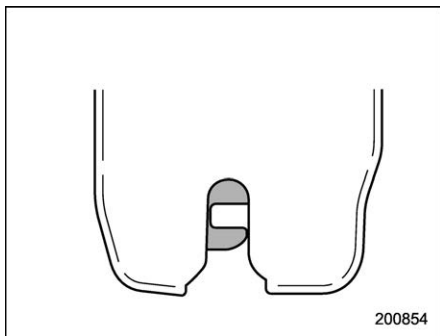

This places the latch in the locked position.

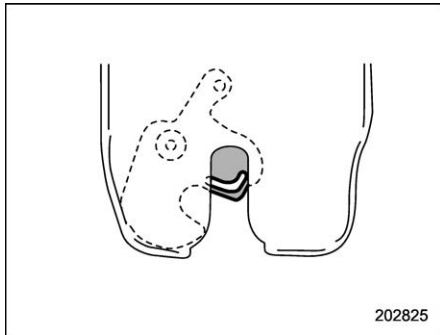

3. Move the release handle, from outside the vehicle, in the direction of the arrow to check if the latch is released.

If the latch is not released, contact your

SUBARU dealer.

In that case, use the key to release the latch, then close the trunk lid.

Also, if the movement of the release handle feels restricted or not entirely smooth during operation, or the handle and/or handle base is cracked, contact your SUBARU dealer.

## Moonroof (if equipped)

### WARNING

Never let anyone's hands, arms, head or any objects protrude from the moonroof. A person could be seriously injured if the vehicle stops suddenly or turns sharply or if the vehicle is involved in an accident.

To avoid serious personal injury caused by accidental, child's mischief, or improper operation, the driver is responsible for obeying the following instructions without exception.

- Before closing the moonroof, make sure that no one's hands, arms, head or other objects will be accidentally caught in the moonroof.
- Always carry the key when you leave the vehicle for safety reasons and never allow an unattended child to remain in the vehicle. Failure to follow this procedure could result in injury to a child operating the moonroof.

- Never try to check the anti-entrapment function by deliberately placing part of your body in the moonroof.

### CAUTION

- Do not sit on the edge of the open moonroof.
- Do not operate the moonroof if falling snow or extremely cold conditions have caused it to freeze shut.
- The anti-entrapment function does not operate when the moonroof is being tilted down. Be sure to confirm that it is safe to do so before tilting the moonroof down.
- If the moonroof does not close, we recommend that you have the system checked by a SUBARU dealer.

The moonroof has both tilting and sliding functions.

The moonroof operates only when the ignition switch is in the "ON" position.

## ■ Moonroof switches

### ▼ Tilting moonroof

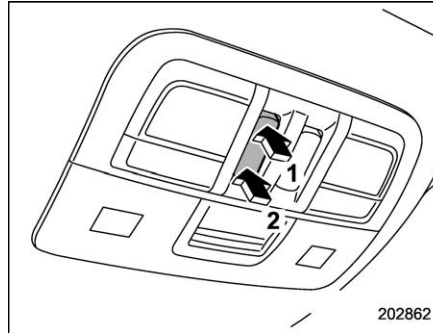

- 1) Raise
- 2) Lower

The tilting function is activated only when the moonroof is fully closed.

#### To raise:

Press and hold the rear side of the "UP/DOWN" switch for a short time. The moonroof raises completely.

#### To lower:

Press and hold the front side of the "UP/DOWN" switch until the preferred position has reached.

Release the switch after the moonroof has been raised or has been lowered comple-

tely. Pressing the switch continuously may cause damage to the moonroof.

### NOTE

One-touch operation does not take place when the moonroof is lowered. Press the switch continuously to lower the moonroof.

### ▼ Sliding moonroof

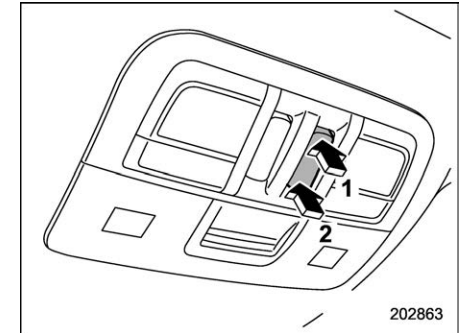

- 1) Open
- 2) Close

Tilt down the moonroof completely before performing the sliding operation.

#### To open:

Press the rear side of the "OPEN/CLOSE" switch. The sunshade will also be opened together with the moonroof. The moonroof will stop once at a midway position. Press

the rear side of the switch again to open the moonroof completely.

**To close:**

Press the front side of the “OPEN/CLOSE” switch.

To stop the moonroof at a selected mid-way position while opening or closing it, momentarily push the switch to the “OPEN” side or “CLOSE” side.

After washing the vehicle or after it rains, wipe away water on the roof prior to opening the moonroof to prevent drops of water from falling into the passenger compartment.

**NOTE**

**Driving with the moonroof fully open can cause an annoying sound to be generated at high speeds. If this occurs, use the moonroof at the midway stop position when the moonroof is opened.**

**▼ Anti-entrapment function**

When the moonroof senses a substantial enough object trapped between its glass and the vehicle’s roof during closure, it automatically moves back to the fully open position and stops there. The anti-entrapment function may also be activated by a strong shock on the moonroof even when there is nothing trapped.



**Never attempt to test this function using fingers, hands or other parts of your body.**

**NOTE**

**For the sake of safety, it is recommended that you avoid driving with the moonroof fully opened.**

**■ Sunshade**

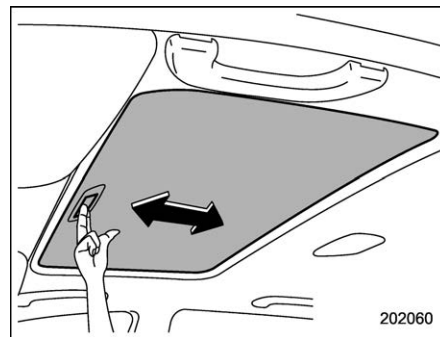

You can slide the sunshade forward or backward by hand while the moonroof is closed.

If the moonroof is opened, the sunshade also moves back.



Ignition switch.....	3-4	Low tire pressure warning light (U.S.-spec. models).....	3-18
Conventional type ignition switch.....	3-5	ABS warning light.....	3-20
Push-button ignition switch.....	3-6	Brake system warning light.....	3-21
Hazard warning flasher .....	3-8	Electronic parking brake indicator light (models with electronic parking brake system).....	3-22
Meters and gauges .....	3-8	Low fuel warning light .....	3-24
Combination meter illumination.....	3-8	Hill start assist warning light/Hill start assist OFF indicator light (models without electronic parking brake system) .....	3-24
Canceling the function for meter/gauge needle movement upon turning on the ignition switch.....	3-9	Auto Vehicle Hold ON indicator light (models with electronic parking brake system).....	3-24
Speedometer .....	3-9	Auto Vehicle Hold operation indicator light (models with electronic parking brake system)...	3-24
Odometer.....	3-9	Door open warning light .....	3-25
Double trip meter .....	3-9	All-Wheel Drive warning light (if equipped).....	3-25
Tachometer.....	3-10	Power steering warning light (except STI) .....	3-25
Fuel gauge.....	3-10	LED headlight warning light (if equipped).....	3-26
Temperature gauge .....	3-11	Vehicle Dynamics Control warning light/Vehicle Dynamics Control operation indicator light .....	3-26
ECO gauge .....	3-12	Vehicle Dynamics Control OFF indicator light/Traction mode indicator light .....	3-27
REV indicator light and buzzer (STI) .....	3-12	Warning chimes and warning indicator of the keyless access with push-button start system (if equipped) .....	3-28
Warning and indicator lights.....	3-13	Security indicator light.....	3-33
Seatbelt warning light and chime .....	3-14	SI-DRIVE indicator (if equipped).....	3-34
SRS airbag system warning light.....	3-15	Gear position indicator (MT models)/Shift-up indicator (STI).....	3-34
Front passenger's frontal airbag ON and OFF indicators .....	3-16	Select lever/gear position indicator (CVT models).....	3-34
CHECK ENGINE warning light/Malfunction indicator light .....	3-16	Turn signal indicator lights .....	3-35
Charge warning light.....	3-17	High beam indicator light.....	3-35
Oil pressure warning light.....	3-17		
Engine low oil level warning indicator (except STI) .....	3-17		
Windshield washer fluid warning indicator .....	3-18		
AT OIL TEMP warning light (CVT models).....	3-18		
Rear differential oil temperature warning light (STI) .....	3-18		

## Instruments and controls

High Beam Assist indicator light (if equipped).....	3-35
Cruise control indicator .....	3-35
Cruise control set indicator.....	3-35
Automatic headlight beam leveler warning light (models with LED headlights).....	3-35
Front fog light indicator light (if equipped) .....	3-35
Headlight indicator light.....	3-35
Driver's control center differential auto indicator (STI) .....	3-36
Driver's control center differential indicator and warning (STI) .....	3-36
REV indicator light (STI).....	3-37
Steering Responsive Headlight warning indicator/ Steering Responsive Headlight OFF indicator (if equipped) .....	3-37
BSD/RCTA warning indicator (if equipped).....	3-37
BSD/RCTA OFF indicator (if equipped) .....	3-37
RAB warning indicator (if equipped).....	3-37
RAB OFF indicator (if equipped).....	3-37
Combination meter display (color LCD) .....	3-37
Basic operation.....	3-38
Welcome screen (opening animation) and Good-bye screen (ending animation) .....	3-39
Warning screen.....	3-39
Basic screens .....	3-39
Warning indication .....	3-40
Menu screens .....	3-41
Multi-function display (color LCD) .....	3-44
Welcome screen .....	3-45
Self-check screen .....	3-45
Interruption screen .....	3-46
Basic operation.....	3-46
Basic screens.....	3-47
Setting screen .....	3-52
How to get the source code using the open source.....	3-63
Clock.....	3-64
Light control switch .....	3-65
Headlights .....	3-65
High/low beam change (dimmer) .....	3-67
Headlight flasher .....	3-70
Daytime running light system .....	3-70
Steering Responsive Headlight (SRH) (if equipped).....	3-71
To turn on/off the SRH.....	3-71
Turn signal lever.....	3-72
One-touch lane changer.....	3-72
Illumination brightness control .....	3-72
Automatic dimming function .....	3-73
Auto dimmer cancel function .....	3-73
Headlight beam leveler (models with LED headlights) .....	3-73
Automatic headlight beam leveler .....	3-73
Fog light switch (if equipped).....	3-73
Wiper and washer.....	3-74
Windshield wiper and washer switches .....	3-75
Mirrors .....	3-77
Inside mirror.....	3-77
Auto-dimming mirror/compass (if equipped).....	3-77
Auto-dimming mirror/compass with HomeLink® (if equipped) .....	3-78
Outside mirrors .....	3-86

**Defogger and deicer ..... 3-86**  
**Tilt/telescopic steering wheel ..... 3-88**

**Horn ..... 3-88**

## Ignition switch

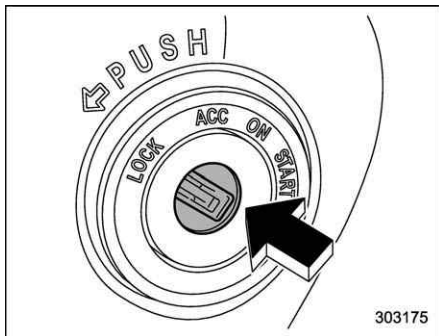

303175

Conventional type ignition switch

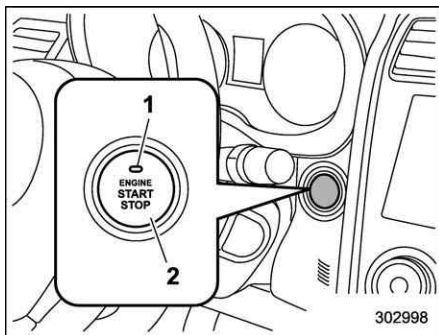

302998

Push-button ignition switch

- 1) Operation indicator
- 2) Push-button ignition switch

The design of the push-button ignition switch may be slightly different depending on the models.

### WARNING

- Before leaving the vehicle, observe the following instructions for safety.
  - Remove the key from the ignition switch (models with conventional type ignition switch).
  - Carry out the access key fob (models with push-button ignition switch).
  - Never allow an unattended child to remain in the vehicle.

Failure to observe these instructions could result in injury to a child or others. Children could operate the power windows, the moonroof or other controls, or even make the vehicle move.

- Never turn the ignition switch to the “LOCK”/“OFF” position while driving or being towed. Doing so will lock the steering wheel, preventing steering control. In addition, when the engine stops, it takes a much greater effort than

usual to steer.

### CAUTION

- To prevent the vehicle battery from discharging, keep the ignition switch in the “LOCK”/“OFF” position when the engine is not running.
- Do not use electrical accessories for a long time with the ignition switch in the “ON” or “ACC” position. Doing so can cause the battery to go dead.

## ■ Conventional type ignition switch

### ⚠ CAUTION

Do not attach a large key holder or key case to either key. If it hits your knees or hands while driving, it could turn the ignition switch to the “ACC” or “LOCK” position, stopping the engine. Also, if the key is attached to a keyholder or to a large bunch of other keys, centrifugal force may act on it as the vehicle moves, resulting in unwanted turning of the ignition switch.

### NOTE

If the key cannot be turned, turn the steering wheel slightly to the left and right as you turn the ignition switch.

## ▼ Switch positions

Position	Description
LOCK	You can insert or remove the key only in this position. The steering wheel will be locked with the key removed.
ACC	You can use the electrical accessories (audio, accessory power outlet, etc.).
ON	Normal operating position after starting the engine
START	The engine is started in this position.

### ⚠ CAUTION

Do not turn the ignition switch to the “START” position while the engine is running.

## NOTE

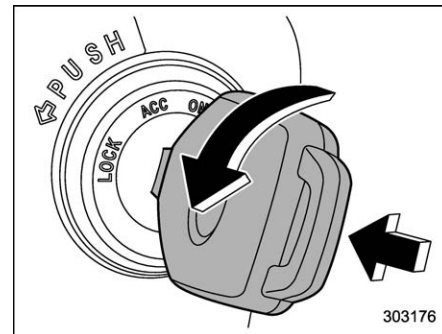

- To turn the key from the “ACC” to “LOCK” position:
  - Place the select lever in the “P” position (CVT models).
  - Push in and turn the key.
- If your registered key fails to start the engine, perform the following procedure to restart the engine.
  - (1) Pull out the key once (the security indicator light will blink).
  - (2) Insert the key again.
  - (3) Return the ignition switch to the “START” position.

- The engine may not start in the following cases:

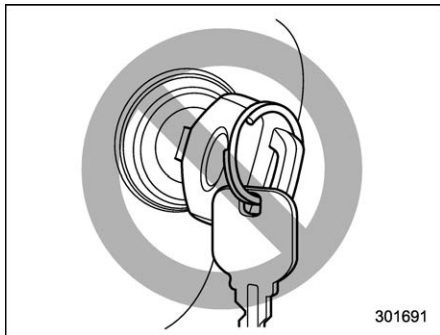

- The key grip is touching another key or a metallic key holder.

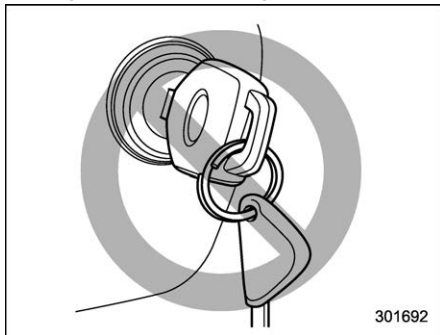

- The key is near another key that contains an immobilizer transpon-

- der.
  - The key is near or touching another transmitter.

#### ▼ Key reminder chime

The reminder chime sounds when opening the driver's door with the ignition switch in the "LOCK" or "ACC" position. The chime stops after the following operation.

- Turning the ignition switch to the "ON" position
- Removing the key from the ignition switch
- Closing the driver's door

#### ▼ Ignition switch light

For easy access to the ignition switch in the dark, the ignition switch light illuminates after the following operation.

- Opening the driver's door
- Unlocking the driver's door using the remote keyless entry transmitter

The light remains illuminated for several tens of seconds and then gradually turns off after the following operation.

- Closing the driver's door
- Unlocking the doors using the remote keyless entry transmitter

The light turns off immediately after the

following operation.

- Turning the ignition switch to the "ON" position
- Locking all doors using the remote keyless entry transmitter

### ■ Push-button ignition switch

#### ▼ Safety precautions

Refer to "Safety precautions" 2-7.

#### ▼ Operating range

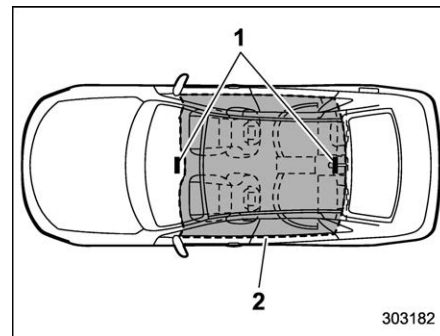

- 1) Antennas
- 2) Operating range

**NOTE**

- If the access key fob is not detected within the operating range, you cannot operate the push-button ignition switch or start the engine.
- Even when the access key fob is outside the vehicle, if it is placed too close to the glass, it may be possible to switch the power or to start the engine.
- Do not leave the access key fob in the following places. It may become impossible to operate the push-button ignition switch or start the engine.
  - On the instrument panel
  - On the floor
  - Inside the glove box
  - Inside the door trim pocket
  - On the rear seat
  - On the rear shelf
  - Inside the trunk
- If the battery of the access key fob is discharged, perform the procedure described in “Access key fob – if access key fob does not operate properly” 9-18 to operate the push-button ignition switch or start the engine. In such a case, replace the battery immediately. Refer to “Replacing battery of access key fob” 11-52.

**▼ Switching power status**

Power status	Indicator color	Operation
OFF	OFF	Power is turned off.
ACC	Orange	You can use the audio and accessory power outlet.
ON	Orange (while the engine is stopped)	You can use all electrical systems.
	OFF (during engine operation)	

The power will be switched every time you press the push-button ignition switch.

1. Carry the access key fob, and sit in the driver's seat.
2. Shift the shift lever in neutral (MT models) or the select lever in the “P” position (CVT models).
3. Press the push-button ignition switch without depressing the clutch pedal (MT models) or the brake pedal (CVT models).

The power will be switched in the sequence of “OFF”, “ACC”, “ON” and “OFF”. When the engine is stopped and the push-button ignition switch is in “ACC” or “ON”, the operation indicator on the push-button ignition switch illuminates in orange.

**CAUTION**

- To avoid a malfunction, observe the following precautions.
  - Do not spill drinks or other liquids on the push-button ignition switch.
  - Do not touch the push-button ignition switch with a hand that is soiled with oil or other contaminants.
- If the push-button ignition switch does not operate smoothly, stop the operation. Contact a SUBARU dealer immediately.
- If the push-button ignition switch does not illuminate even when the instrument panel illumination is on, have the vehicle inspected at a SUBARU dealer.
- If the vehicle was exposed to sunlight for a long time, the surface of the push-button ignition switch may get hot. Be careful not to burn yourself.

**NOTE**

- When operating the push-button ignition switch, firmly press it.
- If you press the push-button ignition switch quickly, the power may not turn on or off.
- If the indicator light on the push-button ignition switch flashes in green when pressing the push-button ignition switch, steering is locked. When this occurs, press the push-button ignition switch while turning the steering wheel left and right.

▽ **Battery drainage prevention function**

When the push-button ignition switch is left in the “ACC” or “ON” position for approximately 1 hour, the push-button ignition switch will be automatically switched to “OFF” to prevent the battery from going dead. (In CVT models, this function is activated when the select lever is in the “P” position.)

▼ **When access key fob does not operate properly**

Refer to “Access key fob – if access key fob does not operate properly” 9-18.

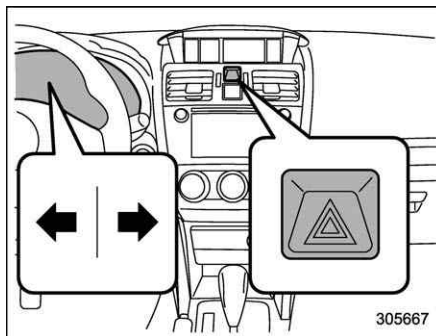
**Hazard warning flasher**

Use the hazard warning flasher to warn other drivers when you have to park your vehicle under emergency conditions. The hazard warning flasher works regardless of the position of the ignition switch.

To turn on the hazard warning flasher, push the hazard warning flasher switch on the instrument panel. All the turn signal lights and the turn signal indicator lights will flash. To turn off the flasher, push the switch again.

**NOTE**

**When the hazard warning flasher is on, the turn signals do not work.**

**Meters and gauges****NOTE**

Liquid-crystal displays are used in some of the meters and gauges on the combination meter. You will find their indications hard to see if you wear polarized glasses.

■ **Combination meter illumination**

When you turn the ignition switch to the “ON” position, the various parts of the combination meter are illuminated in the following sequence.

1. Warning lights, indicator lights, meter needles, gauge needles illuminate.
2. Meter and gauge indications each show MAX position.
3. Meter and gauge indications each show MIN position.
4. Regular illumination (for driving) begins.



**NOTE**

This sequence of operations may not take place if you quickly turn the ignition switch to start the engine. This is not a malfunction.

### ■ Canceling the function for meter/gauge needle movement upon turning on the ignition switch

It is possible to activate or deactivate the movement of the meter needles and gauge needles that takes place when you turn the ignition switch to the "ON" position. To change the setting, perform the procedures described in "Gauge Initial Movement" 3-43.

### ■ Speedometer

The speedometer shows the vehicle speed. The digital speedometer can be also displayed on the combination meter display (color LCD).

### ■ Odometer

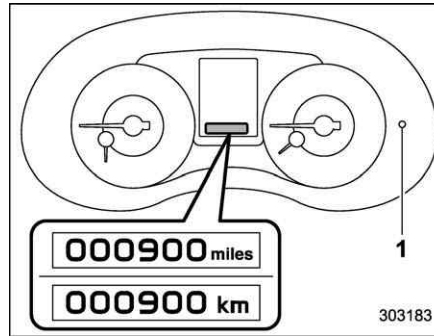

The unit displayed varies depending on the models.

- 1) Trip knob

This meter displays the odometer when the ignition switch is in the "ON" position. The odometer shows the total distance that the vehicle has been driven.

If you press the trip knob when the ignition switch is in the "LOCK"/"OFF" or "ACC" position, the odometer/trip meter will light up. If you do not press the trip knob within 10 seconds of illumination of the odometer/trip meter, the odometer/trip meter will turn off.

Also, if you open and close the driver's door within 10 seconds of illumination of the odometer/trip meter, the odometer/trip

meter will turn off.

### ■ Double trip meter

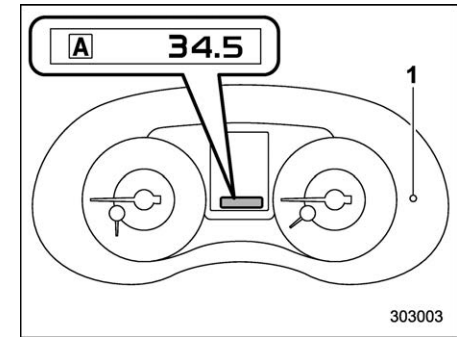

- 1) Trip knob

This meter displays the two trip meters when the ignition switch is in the "ON" position.

The trip meter shows the distance that the vehicle has been driven since you last set it to zero.

If you press the trip knob when the ignition switch is in the "LOCK"/"OFF" or "ACC" position, the odometer/trip meter will light up. It is possible to switch between the A trip meter and B trip meter indications while the odometer/trip meter is lit up. If you do not press the trip knob within 10 seconds of illumination of the odometer/trip

trip meter, the odometer/trip meter will turn off.

Also, if you open and close the driver's door within 10 seconds of illumination of the odometer/trip meter, the odometer/trip meter will turn off.

You can switch the display as shown in the following sequence by pressing the trip knob.

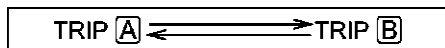

To set the trip meter to zero, select the A trip or B trip meter by pressing the knob and keep the knob pressed for more than 2 seconds.

#### CAUTION

**To ensure safety, do not attempt to change the function of the indicator while driving, as an accident could result.**

#### NOTE

**If the connection between the combination meter and battery is broken for any reason such as vehicle maintenance or fuse replacement, the data recorded on the trip meter will be lost.**

#### ■ Tachometer

The tachometer shows the engine speed in thousands of revolutions per minute.

#### CAUTION

**Do not operate the engine with the pointer of the tachometer in the red zone. In this range, fuel injection will be cut by the engine control module to protect the engine from overrevving. The engine will resume running normally after the engine speed is reduced below the red zone.**

#### ■ Fuel gauge

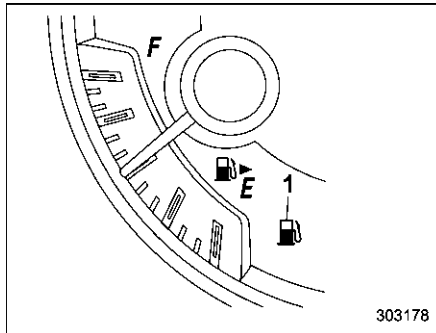

1) Low fuel warning light

The fuel gauge shows the approximate

amount of fuel remaining in the tank.

When the ignition switch is in the "LOCK"/"OFF" or "ACC" position, the fuel gauge shows "E" even if the fuel tank contains fuel.

The gauge may move slightly during braking, turning or acceleration due to fuel level movement in the tank.

If you press the trip knob while the ignition switch is in the "LOCK"/"OFF" or "ACC" position, the fuel gauge's dial will light up and the needle will indicate the amount of fuel remaining in the tank.

If, while the fuel gauge needle is indicating the amount of fuel remaining in the tank, you (a) do not press the trip knob for 10 seconds or (b) open and close the driver's door, the fuel gauge needle will drop to the "E" position and the dial and needle will turn off.

**NOTE**

200253

- You will see the “” sign in the fuel gauge.

This indicates that the fuel filler lid is located on the right side of the vehicle.

- When you have refueled, the fuel gauge indicates the amount in the fuel tank after starting the engine. Also, it may take some time until the fuel gauge indication stabilizes.

- The gauge indicates only an approximate amount of fuel remaining in the tank. Use this indication only as a guide.

- If you refuel while the ignition switch is in the “ON” position, the fuel gauge may not indicate the correct amount of

the fuel in the fuel tank.

- If the refuel amount is less than approximately 4.0 US gal (15 liters, 3.3 Imp gal), it may take some time until the fuel gauge indication stabilizes.

### ■ Temperature gauge

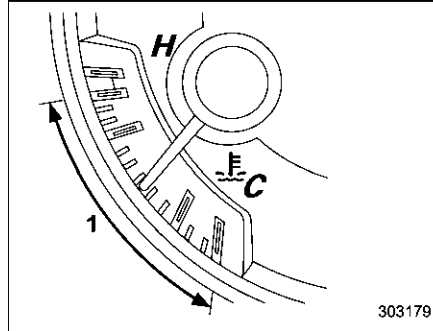

303179

- 1) Normal operating range

The temperature gauge shows engine coolant temperature when the ignition switch is in the “ON” position.

The coolant temperature will vary in accordance with the outside temperature and driving conditions.

We recommend that you drive moderately until the pointer of the temperature gauge reaches near the middle of the range.

Engine operation is optimum with the engine coolant at this temperature range and high revving operation when the engine is not warmed up enough should be avoided.

**CAUTION**

If the pointer exceeds the normal operating range, safely stop the vehicle as soon as possible.

Refer to “Engine overheating”  9-12.

### ■ ECO gauge

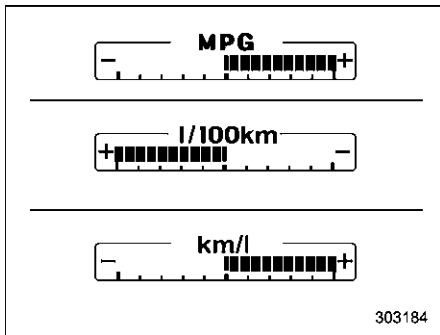

The unit displayed varies depending on the models.

The ECO gauge shows the difference between the average rate of fuel consumption since the trip meter was last reset and the current rate of fuel consumption.

The ECO gauge indicates the current fuel efficiency as shown in the following chart.

Displayed unit	Needle position	
	"+" side	"-" side
MPG	Better	Poorer
l/100km	Poorer	Better
km/l	Better	Poorer

### NOTE

- The ECO gauge shows only an approximate indication.
- After resetting the trip meter, the average rate of fuel consumption is not shown until driving 0.6 mile (1 km). Until that time, the ECO gauge does not operate.

### REV indicator light and buzzer (STI)

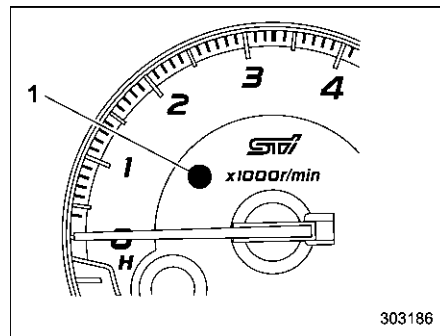

- 1) REV indicator light

The REV alarm system has the following functions.

- When the engine speed reaches the level that was previously set, the REV indicator light illuminates to inform you. At this time, a buzzer also sounds if the buzzer setting is activated.
- Whenever the engine speed enters the red zone of the tachometer, the REV indicator light flashes.

**NOTE**

Even if the REV alarm system is not set, the REV indicator light will flash whenever the engine speed enters the red zone of the tachometer.

To change the REV indicator settings, perform the procedures described in "REV setting (STI)" 3-43.

**Warning and indicator lights**

Several of the warning and indicator lights illuminate when you initially turn the ignition switch to the "ON" position. This permits checking the operation of the bulbs.

Apply the parking brake and turn the ignition switch to the "ON" position. For the system check, the following lights illuminate and then turn off after several seconds or after the engine has started.

: Seatbelt warning light (The seatbelt warning light turns off only when the driver fastens the seatbelt.)

PASSENGER  
: Front passenger's seatbelt warning light (The seatbelt warning light turns off only when the front seat passenger fastens the seatbelt.)

: SRS airbag system warning light

ON / : Front passenger's frontal airbag ON indicator light

OFF / : Front passenger's frontal airbag OFF indicator light

CHECK-ENGINE  
: CHECK ENGINE warning light/Malfunction indicator light

: Charge warning light

: Oil pressure warning light

: REV indicator light (STI)

AT OIL-TEMP  
: AT OIL TEMP warning light (CVT models)

R.DIFF-TEMP  
: Rear differential oil temperature warning light (STI)

: Low tire pressure warning light (U.S.-spec. models)

ABS / : ABS warning light

BRAKE / : Brake system warning light

PARK / : Electronic parking brake indicator light (models with the electronic parking brake system)

: Low fuel warning light

: Hill start assist warning light/Hill start assist OFF indicator light (models without electronic parking brake system)

: Door open warning light

AWD: AWD warning light (if equipped)

: Power steering warning light (except STI)

## 3-14 Instruments and controls/Warning and indicator lights

 Vehicle Dynamics Control warning light/  
Vehicle Dynamics Control operation  
indicator light

 Vehicle Dynamics Control OFF indicator  
light

 LED headlight warning light (if  
equipped)

 Headlight indicator light

 Automatic headlight beam leveler  
warning light (models with LED head-  
lights)

 Traction mode indicator light

If any lights fail to illuminate, it indicates a  
burned-out bulb or a malfunction of the  
corresponding system.

Consult your authorized SUBARU dealer  
for repair.

### ■ Seatbelt warning light and chime



Your vehicle is equipped with a seatbelt  
warning device at the driver's and front  
passenger's seat, as required by current  
safety standards.

With the ignition switch turned to the "ON"  
position, this device reminds the driver and  
front passenger to fasten their seatbelts by  
illuminating the warning lights in the loca-  
tions indicated in the following illustration

and sounding a chime.

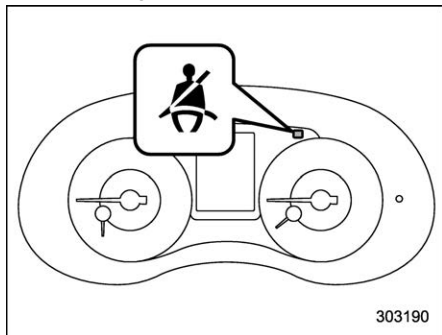

Driver's warning light



Front passenger's warning light

### ▼ Operation

If the driver and/or front passenger have/  
has not yet fastened the seatbelt(s) when  
the ignition switch is turned to the "ON"  
position, the seatbelt warning light(s) will  
illuminate for 6 seconds, to warn that the  
seatbelt(s) is/are unfastened. If the driver's  
seatbelt is not fastened, a chime will also  
sound simultaneously.

### NOTE

- If the driver's and/or front passen-  
ger's seatbelt(s) are/is still not fastened  
6 seconds later, the seatbelt warning  
device operates as follows according  
to the vehicle speed.

- At speeds lower than approxi-  
mately 9 mph (15 km/h)

The warning light(s) for unfastened  
seatbelt(s) will alternate between  
steady illumination and flashing at  
15-second intervals. The chime will  
not sound.

- At speeds higher than approxi-  
mately 9 mph (15 km/h)

The warning light(s) for unfastened  
seatbelt(s) will alternate between  
flashing and steady illumination at  
15-second intervals and the chime  
will sound while the warning light(s)  
is/are flashing.

● It is possible to cancel the warning operation that follows the 6-second warning after turning ON the ignition switch. When the ignition switch is turned ON next time, however, the complete sequence of the warning operation resumes. For further details about canceling the warning operation, please contact your SUBARU dealer.

If there is no passenger on the front passenger's seat, the seatbelt warning device for the front passenger's seat will be deactivated. The front passenger's seatbelt warning system monitors whether or not there is a passenger on the front passenger's seat.

Observe the following precautions. Failure to do so may prevent the device from functioning correctly or cause the device to fail.

- Do not install any accessory such as a table or TV onto the seatback.
- Do not store a heavy load in the seatback pocket.
- Do not allow the rear seat occupant to place his/her hands or legs on the front passenger's seatback, or allow him/her to pull the seatback.
- Do not use front seats with their backward-forward position and seatback not being locked into place securely. If any of

them are not locked securely, adjust them again. For adjusting procedure, refer to "Front seats" 1-2.

If the seatbelt warning device for the front passenger's seat does not function correctly (e.g., it is activated even when the front passenger's seat is empty or it is deactivated even when the front passenger has not fastened his/her seatbelt), take the following actions.

- Ensure that no article is placed on the seat other than a child restraint system and its child occupant, although we strongly recommend that all children sit in the rear seat properly restrained.
- Ensure that there is no article left in the seatback pocket.
- Ensure that the backward-forward position and seatback of front passenger's seat are locked into place securely by moving the seat back and forth.

If still the seatbelt warning device for front passenger's seat does not function correctly after taking relevant corrective actions described above, immediately contact your SUBARU dealer for an inspection.

## ■ SRS airbag system warning light



For details about the SRS airbag system warning light, refer to "SRS airbag system monitors" 1-64.



### WARNING

**If the warning light exhibits any of the following conditions, there may be a malfunction in the seatbelt pretensioners and/or SRS airbag system.**

- **Flashing or flickering of the warning light**
- **No illumination of the warning light when the ignition switch is first turned to the "ON" position**
- **Continuous illumination of the warning light**
- **Illumination of the warning light while driving**

**Immediately take your vehicle to your nearest SUBARU dealer to have the system checked. Unless checked and properly repaired, the seatbelt pretensioners and/or SRS airbag will not operate properly in the event of a collision, which may increase the risk of injury.**

### ■ Front passenger's frontal air-bag ON and OFF indicators



ON / : Front passenger's frontal airbag ON indicator

OFF / : Front passenger's frontal airbag OFF indicator

The front passenger's frontal airbag ON and OFF indicators show you the status of the front passenger's SRS frontal airbag. The indicators are located next to the clock in the center portion of the dashboard.

When the ignition switch is turned to the "ON" position, both the ON and OFF indicators illuminate for 6 seconds during which time the system is checked. Following the system check, both indicators turn off for 2 seconds. After that, one of the indicators illuminates depending on the status of the front passenger's SRS frontal

airbag determined by the SUBARU advanced frontal airbag system monitoring. If the front passenger's SRS frontal airbag is activated, the passenger's frontal airbag ON indicator will illuminate while the OFF indicator will remain off.

If the front passenger's SRS frontal airbag is deactivated, the passenger's frontal airbag ON indicator will remain off while the OFF indicator will illuminate.

With the ignition switch turned to the "ON" position, if both the ON and OFF indicators remain illuminated or off simultaneously even after the system check period, the system is malfunctioning. Contact your SUBARU dealer immediately for an inspection.

### ■ CHECK ENGINE warn- ing light/Malfunction indicator light

CHECK  
ENGINE

#### CAUTION

**If the CHECK ENGINE light illuminates while you are driving, have your vehicle checked/repaired by your SUBARU dealer as soon as possible. Continued vehicle operation without having the emission control system checked and repaired as necessary could cause**

**serious damage, which may not be covered by your vehicle's warranty.**

If this light illuminates steadily or blinks while the engine is running, it may indicate that there is at least one problem or potential problem somewhere in the emission control system.

#### ▼ If the light illuminates steadily

If the light illuminates steadily while driving or does not turn off after the engine starts, an emission control system malfunction has been detected.

You should have your vehicle checked by an authorized SUBARU dealer immediately.

#### NOTE

**This light also illuminates when the fuel filler cap is not tightened until it clicks.**

If you have recently refueled your vehicle, the cause of the CHECK ENGINE warning light/malfunction indicator light illuminating could be a loose or missing fuel filler cap. Remove the cap and retighten it until it clicks. Make sure nothing is interfering with the sealing of the cap. Tightening the cap will not make the CHECK ENGINE warning light/malfunction indicator light turn off immediately. It may take several driving trips. If the light does not turn off, take your



vehicle to your authorized SUBARU dealer immediately.

### ▼ If the light is blinking

If the light is blinking while driving, an engine misfire condition has been detected which may damage the emission control system.

To prevent serious damage to the emission control system, you should do the following.

- Reduce vehicle speed.
- Avoid hard acceleration.
- Avoid steep uphill grades.
- Reduce the amount of cargo, if possible.

The CHECK ENGINE warning light may stop blinking and illuminate steadily after several driving trips. You should have your vehicle checked by an authorized SUBARU dealer immediately.

### ■ Charge warning light



If this light illuminates when the engine is running, it may indicate that the charging system is not working properly.

If the light illuminates while driving or does not turn off after the engine starts, stop the engine at the first safe opportunity and check the alternator belt. If the belt is

loose, broken or if the belt is in good condition but the light remains illuminated, contact your nearest SUBARU dealer immediately.

### ■ Oil pressure warning light



If this light illuminates when the engine is running, it may indicate that the engine oil pressure is low and the lubricating system is not working properly.

If the light illuminates while driving or does not turn off after the engine starts, stop the engine at the first safe opportunity and contact your nearest SUBARU dealer immediately.



### CAUTION

**Do not operate the engine with the oil pressure warning light on. This may cause serious engine damage.**

### ■ Engine low oil level warning indicator (except STI)



This indicator appears when the engine oil level decreases to the lower limit.

If the engine low oil level warning indicator appears while driving, park the vehicle in a

safe and level location, and then check the engine oil level. When the engine oil level is not within the normal range, refill with engine oil. Refer to “Engine oil” 11-13.

If the warning indicator does not disappear after refilling the engine oil, or the warning indicator appears even though the engine oil level is within the normal range, have the vehicle checked by a SUBARU dealer.

### NOTE

- **After replacing or adding the engine oil, if the engine oil level is within the normal range when restarting the engine on a level surface, the warning indicator will be off.**
- **The warning indicator may appear temporarily in the following conditions because a low oil level may be detected as a result of significant oil movement in the engine.**
  - The vehicle is considerably inclined on an uphill or steep slope.
  - The vehicle has continuously accelerated and decelerated.
  - The vehicle is continuously turned.
  - The vehicle is driven on a road that alternates continuously between uphill and downhill.

■ Windshield washer fluid warning indicator



This indicator appears when the fluid level in the windshield washer fluid tank decreases to the lower limit (approximately 1.1 US qt, 1.0 liter, 0.9 Imp qt).

■ AT OIL TEMP warning light (CVT models)



If this light illuminates when the engine is running, it may indicate that the transmission fluid temperature is too hot.

If the light illuminates while driving, immediately stop the vehicle in a safe place and let the engine idle until the warning light turns off.

▼ Transmission control system warning

If the "AT OIL TEMP" warning light flashes after the engine has started, it may indicate that the transmission control system is not working properly. Contact your nearest SUBARU dealer for service immediately.

■ Rear differential oil temperature warning light (STI)



If the R.DIFF TEMP warning light illuminates, reduce vehicle speed and stop the vehicle in a safe location as soon as possible. Continuing to drive with this light illuminated may damage the rear differential and other parts of the powertrain.

If this light illuminates when the engine is running, it may indicate that the rear differential oil temperature is too hot.

At this time, the driver's control center differential will automatically cancel the current torque-distribution ratio setting and adopt its minimum ratio.

If the light illuminates while driving, reduce vehicle speed and stop the vehicle in the nearest safe location. Park the vehicle for several minutes. After the light turns off, you can start driving.

If the light does not turn off, contact the nearest SUBARU dealer for service.

NOTE

- If the tire pressures are not correct and/or the tires are not all the same size and brand, the rear differential will be heavily loaded when the vehicle is driven, resulting in an abnormally high oil temperature.
- The rear differential oil will deteriorate if its temperature increases enough for the rear differential oil temperature warning light to illuminate. It is advisable to have the rear differential oil replaced as soon as possible.

■ Low tire pressure warning light (U.S.-spec. models)



When the ignition switch is turned to the "ON" position, the low tire pressure warning light will illuminate for approximately 2 seconds to check that the tire pressure monitoring system (TPMS) is functioning properly. If there is no problem and all tires are properly inflated, the light will turn off. Each tire, including the spare (if provided), should be checked monthly when cold and inflated to the inflation pressure recommended by the vehicle manufacturer on the vehicle placard or tire inflation pressure label. (If your vehicle has tires of a different size than the size indicated on the

vehicle placard or tire inflation pressure label, you should determine the proper tire inflation pressure for those tires.)

As an added safety feature, your vehicle has been equipped with a tire pressure monitoring system (TPMS) that illuminates a low tire pressure telltale when one or more of your tires is significantly under-inflated. Accordingly, when the low tire pressure telltale illuminates, you should stop and check your tires as soon as possible, and inflate them to the proper pressure. Driving on a significantly under-inflated tire causes the tire to overheat and can lead to tire failure. Under-inflation also reduces fuel efficiency and tire tread life, and may affect the vehicle's handling and stopping ability.

Please note that the TPMS is not a substitute for proper tire maintenance, and it is the driver's responsibility to maintain correct tire pressure, even if under-inflation has not reached the level to trigger illumination of the TPMS low tire pressure telltale.

Your vehicle has also been equipped with a TPMS malfunction indicator to indicate when the system is not operating properly. The TPMS malfunction indicator is combined with the low tire pressure telltale. When the system detects a malfunction, the telltale will flash for approximately one

minute and then remain continuously illuminated. This sequence will continue upon subsequent vehicle start-ups as long as the malfunction exists. When the malfunction indicator is illuminated, the system may not be able to detect or signal low tire pressure as intended. TPMS malfunctions may occur for a variety of reasons, including the installation of replacement or alternate tires or wheels on the vehicle that prevent the TPMS from functioning properly. Always check the TPMS malfunction telltale after replacing one or more tires or wheels on your vehicle to ensure that the replacement or alternate tires and wheels allow the TPMS to continue to function properly.

Should the warning light illuminate steadily after blinking for approximately one minute, have the system inspected by your nearest SUBARU dealer as soon as possible.



### WARNING

**If this light does not illuminate briefly after the ignition switch is turned ON or the light illuminates steadily after blinking for approximately one minute, you should have your Tire Pressure Monitoring System checked at a SUBARU dealer as soon as possible.**

**If this light illuminates while driving, never brake suddenly. Instead, perform the following procedure. Otherwise an accident involving serious vehicle damage and serious personal injury could occur.**

- 1) Keep driving straight ahead while gradually reducing speed.**
- 2) Slowly pull off the road to a safe place.**

**If this light still illuminates while driving after adjusting the tire pressure, a tire may have significant damage and a fast leak that causes the tire to lose air rapidly. If you have a flat tire, refer to "Flat tires" 9-4.**

**When a spare tire is mounted or a wheel rim is replaced without the original pressure sensor/transmitter being transferred, the Low tire pressure warning light will illuminate steadily after blinking for approximately one minute. This indicates the TPMS is unable to monitor all four road wheels. Contact your SUBARU dealer as soon as possible for tire and sensor replacement and/or system resetting.**

**If the light illuminates steadily after blinking for approximately one minute, promptly contact a SUBARU**

dealer to have the system inspected.

 CAUTION

The tire pressure monitoring system is NOT a substitute for manually checking tire pressure. The tire pressure should be checked periodically (at least monthly) using a tire gauge. After any change to tire pressure(s), the tire pressure monitoring system will not re-check tire inflation pressures until the vehicle is first driven to a vehicle speed of at least 20 mph (32 km/h). After adjusting the tire pressures, increase the vehicle speed to at least 20 mph (32 km/h) to start the TPMS re-checking of the tire inflation pressures. If the tire pressures are now above the severe low pressure threshold, the low tire pressure warning light should turn off a few minutes later. Therefore, be sure to install the specified size for the front and rear tires.

■ ABS warning light 

 CAUTION

- If any of the following conditions occur, we recommend that you have the ABS system repaired at the first available opportunity by your SUBARU dealer.
  - The warning light does not illuminate when the ignition switch is turned to the “ON” position.
  - The warning light illuminates when the ignition switch is turned to the “ON” position, but it does not turn off even after starting the vehicle.
  - The warning light illuminates while driving.
- When the warning light is on (and the brake system warning light is off), the ABS function shuts down. However, the conventional brake system continues to operate normally.

The ABS warning light illuminates together with the brake system warning light if the EBD system malfunctions. For further details of the EBD system malfunction warning, refer to “Brake system warning

light” 3-21.

**NOTE**

If the warning light behavior is as described in the following conditions, the ABS system may be considered normal.

- The warning light illuminates when the ignition switch is turned to the “ON” position and turns off approximately 2 seconds after the engine has started.
- The warning light illuminates right after the engine is started but turns off immediately, remaining off.
- The warning light remains illuminated after the engine has been started, but it turns off while driving.
- The warning light illuminates while driving, but it turns off immediately and remains off.

When driving with an insufficient battery voltage such as when the engine is jump started, the ABS warning light may illuminate. This is due to the low battery voltage and does not indicate a malfunction. When the battery becomes fully charged, the light will turn off.

## ■ Brake system warn- BRAKE / (!)

### WARNING

- Driving with the brake system warning light on is dangerous. This indicates your brake system may not be working properly. If the light remains illuminated, have the brakes inspected by a SUBARU dealer immediately.
- If at all in doubt about whether the brakes are operating properly, do not drive the vehicle. Have your vehicle towed to the nearest SUBARU dealer for repair.
- For models with the electronic parking brake: If the brake system warning light illuminates, the electronic parking brake system may be malfunctioning. Immediately stop your vehicle in a safe location, use tire stops under the tires to prevent the vehicle from moving and contact your SUBARU dealer. For details, refer to “Electronic parking brake (models with electronic parking brake system)” 7-42.

## NOTE

For models with the electronic parking brake:

- Even if the brake system warning light illuminates, if the warning light behavior is as described in the following examples, the electronic parking brake system is not malfunctioning.
  - The warning light turns off when the electronic parking brake is applied or released.
  - The warning light turns off when the ignition switch is turned to the “ON” position again.
- The brake system warning light may illuminate immediately after the engine is started. However, it is not malfunctioning if the warning light turns off after the electronic parking brake is released.
- The brake system warning light may illuminate after the electronic parking brake is frequently applied and released. However, the electronic parking brake system is not malfunctioning if the light turns off for a short period of time.
- When the engine is started while the electronic parking brake is applied/released, the system may judge an abnormal situation and the warning

light may illuminate. If the warning light illuminates, turn the ignition switch once to the “LOCK”/“OFF” position and then restart the engine. Then, apply/release the electronic parking brake. If the warning light turns off, the system will be restored.

This light has the following functions.

### ▼ Parking brake indicator (models without electronic parking brake system)

This light illuminates with the parking brake applied while the ignition switch is in the “ON” position. It turns off when the parking brake is fully released.

### ▼ Brake fluid level warning

This light illuminates when the brake fluid level has dropped to near the “MIN” level of the brake fluid reservoir with the ignition switch in the “ON” position and with the parking brake fully released.

If the brake system warning light should illuminate while driving (with the parking brake fully released and with the ignition switch positioned in “ON”), it could be an indication of leaking of brake fluid or worn brake pads. If this occurs, immediately stop the vehicle at the nearest safe place and check the brake fluid level. If the fluid level is below the “MIN” mark in the

reservoir, do not drive the vehicle. Have the vehicle towed to the nearest SUBARU dealer for repair.

### ▼ **Electronic Brake Force Distribution (EBD) system warning**

The brake system warning light also illuminates if a malfunction occurs in the EBD system. In that event, it illuminates together with the ABS warning light.

The EBD system may be malfunctioning if the brake system warning light and ABS warning light illuminate simultaneously while driving.

Even if the EBD system fails, the conventional braking system will still function. However, the rear wheels will be more prone to locking when the brakes are applied harder than usual and the vehicle's motion may therefore become somewhat harder to control.

If the brake system warning light and ABS warning light illuminate simultaneously, take the following steps.

1. Stop the vehicle in the nearest safe, flat place.
2. Shut down the engine, apply the parking brake and then restart it.
3. Release the parking brake. If both warning lights turn off, the EBD system may be malfunctioning. Drive carefully to the nearest SUBARU dealer and have the

system inspected.

4. If both warning lights illuminate again and remain illuminated after the engine has been restarted, shut down the engine again, apply the parking brake, and check the brake fluid level.

5. If the brake fluid level is not below the "MIN" mark, the EBD system may be malfunctioning. Drive carefully to the nearest SUBARU dealer and have the system inspected.

6. If the brake fluid level is below the "MIN" mark, DO NOT drive the vehicle. Instead, have the vehicle towed to the nearest SUBARU dealer for repair.

### ▼ **Electronic parking brake system warning (models with electronic parking brake system)**

The brake system warning light illuminates when the electronic parking brake system is malfunctioning. If the warning light illuminates, promptly park in a safe location as soon as possible and contact your SUBARU dealer.

The brake system warning light remains illuminated when the parking brake cannot be released even if the parking brake switch is pushed. For details, refer to "Electronic parking brake (models with electronic parking brake system)" 7-42.

### ▽ **Frequent operation warning**

The brake system warning light illuminates and a chirp sound will be heard if the parking brake switch is operated too frequently. In this case, the operation of the parking brake switch is restricted to protect the electronic parking brake system.

### ▼ **Vacuum pump system warning (except STI)**

This light illuminates when a malfunction is detected in the vacuum pump system.

### **NOTE**

**The vacuum pump system assists the boost pressure when driving at high altitudes while the engine is cold.**

### ■ **Electronic parking brake indicator light (models with electronic parking brake system)**

#### ▼ **Parking brake indicator**

The light illuminates with the parking brake applied while the ignition switch is in the "ON" position. It turns off when the parking brake is fully released.

▼ **Electronic parking brake system warning**

 **WARNING**

- When you release the electronic parking brake while the engine is running, the electronic parking brake indicator light will turn off. However, if the light still illuminates, stop the vehicle in a safe place immediately and have the system inspected by a SUBARU dealer.
- If at all in doubt about whether the brakes are operating properly, do not drive the vehicle. Have your vehicle towed to the nearest SUBARU dealer for repair.
- If the electronic parking brake indicator light flashes, the electronic parking brake system may be malfunctioning. Immediately stop your vehicle in a safe location, use tire stops under the tires to prevent the vehicle from moving and contact your SUBARU dealer. For details, refer to “Electronic parking brake (models with electronic parking brake system)” 7-42.

**NOTE**

- When the ignition switch is turned to the “LOCK”/“OFF” position with the electronic parking brake applied, the electronic parking brake indicator light remains illuminated for approximately 30 seconds and then turns off.
- When the electronic parking brake switch is pulled to apply the electronic parking brake while the ignition switch is in the “LOCK”/“OFF” position, the electronic parking brake indicator light illuminates, remains illuminated for approximately 30 seconds and then turns off.
- Even if the electronic parking brake indicator light flashes, if the warning light behavior is as described in the following examples, the electronic parking brake system is not malfunctioning.
  - The indicator light turns off when the electronic parking brake is released.
- The electronic parking brake indicator light may flash immediately after the engine is started. However, it is not malfunctioning if the indicator light turns off after the electronic parking brake is released.

- The electronic parking brake indicator light may flash after the electronic parking brake is frequently applied and released. However, the electronic parking brake system is not malfunctioning if the light turns off for a short period of time.

The electronic parking brake indicator light flashes when the electronic parking brake system is malfunctioning. If the indicator light flashes, promptly park in a safe location as soon as possible and contact your SUBARU dealer.

The electronic parking brake indicator light remains illuminated when the parking brake cannot be released even if the parking brake switch is pushed. For details, refer to “Electronic parking brake (models with electronic parking brake system)” 7-42.

▽ **Parking brake apply inhibit warning**

The electronic parking brake indicator light flashes for 10 seconds and a chirp sound will be heard if the parking brake switch is operated when the parking brake cannot be applied.

▽ **Frequent operation warning**

The electronic parking brake indicator light flashes for 10 seconds and a chirp sound will be heard if the parking brake switch is operated too frequently. In this case, the operation of the parking brake switch is restricted to protect the electronic parking brake system.

**NOTE**

Wait until the indicator light turns off.

■ **Low fuel warning light**



The low fuel warning light illuminates when the tank is nearly empty, at approximately 2.6 US gal (10.0 liters, 2.2 Imp gal). It only operates when the ignition switch is in the "ON" position.

 **CAUTION**

**Promptly put fuel in the tank whenever the low fuel warning light illuminates. Engine misfires as a result of an empty tank could cause damage to the engine.**

■ **Hill start assist warning light/Hill start assist OFF indicator light (models without electronic parking brake system)**



▽ **Hill start assist warning light**

While the engine is running, if there are any malfunctions in the Hill start assist system, the warning light will illuminate.

 **WARNING**

**When the Hill start assist warning light illuminates, have the vehicle inspected at an authorized SUBARU dealer.**

▽ **Hill start assist OFF indicator light**

While the Hill start assist system is deactivated, the Hill start assist OFF indicator light illuminates continuously to inform the driver that the Hill start assist system is not operational.

■ **Auto Vehicle Hold ON indicator light (models with electronic parking brake system)** **AVH**

 **CAUTION**

**If the Auto Vehicle Hold ON indicator light does not illuminate even when the Auto Vehicle Hold switch is pressed to activate the Auto Vehicle Hold function, the electronic parking brake system may be malfunctioning. Immediately stop the vehicle in a safe location and contact your SUBARU dealer.**

This indicator light illuminates when the Auto Vehicle Hold is activated. For details, refer to "To turn on/off the Auto Vehicle Hold function" 7-47.

■ **Auto Vehicle Hold operation indicator light (models with electronic parking brake system)** 

This indicator light illuminates while the vehicle is stopped by the Auto Vehicle Hold function. For details, refer to "To operate the Auto Vehicle Hold function" 7-47.



## ■ Door open warning light

The warning light illuminates if any door or the trunk lid is not fully closed. This function is effective even if the ignition switch is in the "LOCK"/"OFF" or "ACC" position, or the key is removed from the ignition switch.

Always make sure this light is not illuminated before you start to drive.

## ■ All-Wheel Drive warning light (if equipped) **AWD**

This light flashes if the vehicle is driven with tires of differing diameters fitted on the wheels or with an excessively low air pressure in any of the tires.

### WARNING

Continued driving with the AWD warning light flashing can lead to powertrain damage. If the AWD warning light flashes, promptly park in a safe location and then check whether all four tires are the same diameter and whether any of the tires has a puncture or has lost air pressure.

## NOTE

If the temporary spare tire is used, the AWD warning light may flash. Use of the temporary spare tire should therefore be restricted to the minimum time necessary. Replace the temporary spare tire with a conventional tire as soon as possible.

## ■ Power steering warning light (except STI)

While the engine is running, this warning light illuminates when a malfunction has been detected in the electric power steering system.

### CAUTION

When the power steering warning light is illuminated, there may be more resistance when the steering wheel is operated. Drive carefully to the nearest SUBARU dealer and have the vehicle inspected immediately.

## NOTE

If the steering wheel is operated in the following ways, the power steering control system may temporarily limit the power assist in order to prevent the system components, such as the control computer and drive motor, from overheating.

- The steering wheel is operated frequently and turned sharply while the vehicle is maneuvered at extremely low speeds, such as while frequently turning the steering wheel during parallel parking.
- The steering wheel remains in the fully turned position for a long period of time.

At this time, there will be more resistance when steering. However, this is not a malfunction. Normal steering force will be restored after the steering wheel is not operated for a while and the power steering control system has an opportunity to cool down. However, if the power steering is operated in a non-standard way which causes power assist limitation to occur too frequently, that may result in a malfunction of the power steering control system.

■ **LED headlight warning light (if equipped)** 

This light illuminates if the LED headlights malfunction. Have your vehicle inspected at a SUBARU dealer as soon as possible.

■ **Vehicle Dynamics Control warning light/Vehicle Dynamics Control operation indicator light** 

▼ **Vehicle Dynamics Control warning light**

 **CAUTION**

The Vehicle Dynamics Control system provides its ABS control through the electrical circuit of the ABS. Accordingly, if the ABS is inoperative, the Vehicle Dynamics Control system becomes unable to provide ABS control. As a result, the Vehicle Dynamics Control system also becomes inoperative, causing the warning light to illuminate. Though both the Vehicle Dynamics Control and ABS are inoperative in this case, the ordinary functions of the brake system are still available. You will be safe while driving with

this condition, but drive carefully and have your vehicle checked at a SUBARU dealer as soon as possible.

**NOTE**

- If the electrical circuit of the Vehicle Dynamics Control system itself malfunctions, the warning light only illuminates. At this time, the ABS (Anti-lock Brake System) remains fully operational.
- The warning light illuminates when the electronic control system of the ABS/Vehicle Dynamics Control system malfunctions.

The Vehicle Dynamics Control system is probably inoperative under any of the following conditions. Have your vehicle checked at a SUBARU dealer immediately.

- The warning light does not illuminate when the ignition switch is turned to the “ON” position.
- The warning light illuminates while the vehicle is running.

**NOTE**

If the warning light behavior is as described in the following examples, the Vehicle Dynamics Control system may be considered normal.

- The warning light illuminates when the ignition switch is turned to the “ON” position and turns off approximately 2 seconds after the engine has started.
- The warning light illuminates right after the engine is started but turns off immediately, remaining off.
- The warning light illuminates after the engine has started and turns off while the vehicle is subsequently being driven.
- The warning light illuminates while driving, but it turns off immediately and remains off.
- The warning light illuminates when the engine has stalled and continues to illuminate after the engine has been restarted. However, it will turn off once the vehicle starts moving.

▼ **Vehicle Dynamics Control operation indicator light**

The indicator light flashes during activation of the skid suppression function and during activation of the traction control function.

**NOTE**



- **The light may remain illuminated for a short period of time after the engine has been started, especially in cold weather. This does not indicate the existence of a problem. The light should turn off as soon as the engine has warmed up.**
- **The indicator light illuminates when the engine has developed a problem and the CHECK ENGINE warning light/malfunction indicator light is on.**

The Vehicle Dynamics Control system is probably malfunctioning under the following condition. Have your vehicle checked at a SUBARU dealer as soon as possible.

- The light does not turn off even after the lapse of several minutes (the engine has warmed up) after the engine has started.

■ **Vehicle Dynamics Control OFF indicator light/Traction mode indicator light**

The indicator light shows the activated/deactivated conditions as follows.

		Activated/deactivated status for each function		
		Traction Control	Vehicle Dynamics Control system	ABS
Indicator light	Turn off	Activated	Activated	Activated
		Deactivated	Activated	Activated
		Deactivated	Deactivated	Activated

For details about the Traction Control and Vehicle Dynamics Control system, refer to “Vehicle Dynamics Control system” 7-37.

### ▼ Vehicle Dynamics Control OFF indicator light

This light illuminates when the Vehicle Dynamics Control OFF switch is operated to select the traction mode or the Vehicle Dynamic Control OFF mode. For details, refer to “Vehicle Dynamics Control system” 7-37.

#### NOTE

- The light may remain illuminated for a while after the engine has been started, especially in cold weather. This does not indicate the existence of a problem. The light should turn off as soon as the engine has warmed up.
- The indicator light illuminates when the engine has developed a problem and the CHECK ENGINE warning light/malfunction indicator light is on.

The Vehicle Dynamics Control system is probably malfunctioning under the following conditions. Have your vehicle checked at a SUBARU dealer as soon as possible.

- The light does not illuminate when the ignition switch is turned to the “ON” position.
- The light does not turn off even after the lapse of several minutes (the engine has warmed up) after the engine has started.

### ▼ Traction mode indicator light

The light illuminates when the Vehicle Dynamics Control OFF switch is pressed briefly to select the traction mode. For details, refer to “Traction mode” 7-39.

### ■ Warning chimes and warning indicator of the keyless access with push-button start system (if equipped)

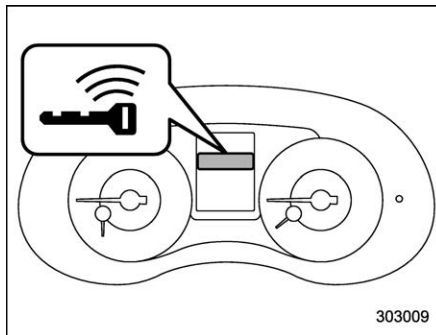

#### Access key warning light

The warning chime and the access key warning light serve the following purposes:

- To minimize improper operation of the keyless access with push-button start system.
- To protect your vehicle from theft.

When the warning chime sounds and/or the warning indicator appears, take the appropriate action.



#### WARNING

Never drive the vehicle if the indicator on the push-button ignition switch is flashing in green when starting the engine. This indicates the status that the steering wheel is not released and could result in an accident involving serious injury or death.



#### CAUTION

- When starting the engine again after the operation indicator on the push-button ignition switch flashes in green, if the operation indicator is still flashing in green, there could be a steering lock malfunction. Contact your SUBARU dealer as soon as possible.

- When the operation indicator on the push-button ignition switch flashes in orange, contact a SUBARU dealer immediately.

## NOTE

- When doors are not locked because the access key fob is left inside the trunk, you cannot open the trunk lid by pushing the trunk opener button on the trunk lid. Press the trunk opener switch for approximately 1 second to open the trunk lid. Refer to “To open the trunk lid from inside” 2-36.
- Do not leave the access key fob inside the trunk. Depending on the status of the access key fob and situation, the trunk lockout protect function may not operate. Make sure that you carry the access key fob, and close the trunk lid.
- Even when the access key fob is within the operating ranges inside the vehicle, the access key warning for engine start may be provided depending on the status of the access key fob and the environmental conditions.

- When the access key fob is taken out of the vehicle through an open window, the access key takeout warning or passenger access key takeout warning will not be provided.

## ▼ List of warnings

### CAUTION

When any of the following warnings occurs even if the access key warning indicator does not appear, take the appropriate action.

### 3-30 Instruments and controls/Warning and indicator lights

Inside warning chime	Outside warning chime	Operation indicator on push-button ignition switch	Status	Action
Ding, ding ... (intermittent)	—	—	The driver's door was opened while the push-button ignition switch is "ACC" (in CVT models, when the select lever is in the "P" position).	Switch the push-button ignition switch to "OFF", or close the driver's door. When exiting the vehicle, be sure to switch the push-button ignition switch to "OFF".
			The push-button ignition switch was switched to "OFF" while the driver's door is open.	Close the driver's door.
Ding	Short beep (2 seconds)	—	<b>Lockout warning:</b> All doors were closed after the locking of all doors was set by using the door lock lever or power door locking switch while the access key fob is inside the vehicle.	Take out the access key fob from the vehicle, and lock the doors. The doors cannot be locked while the access key fob is inside the vehicle. A chirp sound will be heard, and all doors will be unlocked.
—	Short beep (2 seconds)	—	<b>Trunk lockout warning:</b> The trunk was closed with the access key fob in it while all doors are locked (or during the automatic lock time period).	Take out the access key fob from the trunk, and close the trunk. By pressing the trunk opener button after this warning chime sounds, the trunk can be unlocked.
			<b>Access key lock-in warning:</b> The door lock sensor was touched while the push-button ignition switch is "OFF" and the access key fob is inside the vehicle.	Take out the access key fob from the vehicle, and lock the doors. If the access key fob is inside the vehicle, the doors cannot be locked.
—	Beep, beep ... (5 beeps)	—	<b>Door ajar warning:</b> The door lock sensor is touched while the push-button ignition switch is in the "OFF" position and another door or the trunk is opened.	Close the doors securely and lock them. If one of the doors is opened, the doors cannot be locked.

Inside warning chime	Outside warning chime	Operation indicator on push-button ignition switch	Status	Action
Ding	Long beep (60 seconds max.)	—	<b>Power warning:</b> The door lock sensor was touched while carrying the access key fob and the push-button ignition switch is in a position other than "OFF" and the select lever is in the "P" position.	Open the door and return the access key fob inside the vehicle, or switch the push-button ignition switch to "OFF". If the push-button ignition switch is not switched to "OFF", the doors cannot be locked.
Ding, ding ... (7 seconds)	—	—	<b>Access key warning:</b> The vehicle was driven while the access key fob is not inside the vehicle.	Carry the access key fob, and drive the vehicle.
Ding	—	—	<b>Access key warning for engine start:</b> The push-button ignition switch was pressed while the access key fob is not inside the vehicle.	Carry the access key fob, and press the push-button ignition switch.
Ding	Beep, beep, beep (3 beeps)	—	<b>Access key takeout warning:</b> The driver exited the vehicle with the access key fob and closed the driver's door while the push-button ignition switch is in a position other than "OFF" and the select lever is in the "P" position.	Switch the push-button ignition switch to "OFF", and get out of the vehicle.
Ding	Beep, beep, beep (3 beeps)	—	<b>Passenger access key takeout warning:</b> A fellow passenger exited the vehicle with the access key fob and closed a door other than the driver's door while the push-button ignition switch is in a position other than "OFF".	Return the access key fob to inside the vehicle, or switch the push-button ignition switch to "OFF".
Long beep (continuous)	Long beep (continuous)	—	<b>Access key takeout without "P" position warning:</b> The driver exited the vehicle with the access key fob and closed the driver's door while the push-button ignition switch is in a position other than "OFF" and the select lever is in a position other than the "P" position.	Shift the select lever to the "P" position, switch the push-button ignition switch to "OFF" and exit the vehicle.

### 3-32 Instruments and controls/Warning and indicator lights

Inside warning chime	Outside warning chime	Operation indicator on push-button ignition switch	Status	Action
Long beep (continuous)	—	—	<b>Select lever position warning:</b> <ul style="list-style-type: none"> <li>Case 1: The driver's door was opened while the push-button ignition switch is in a position other than "OFF" and the select lever is in a position other than the "P" position.</li> <li>Case 2: The engine is turned off by pressing the push-button ignition switch and the select lever is in a position other than the "P" position.</li> </ul>	<ul style="list-style-type: none"> <li>Case 1: Shift the select lever to the "P" position, switch the push-button ignition switch to "OFF" and exit the vehicle.</li> <li>Case 2: Start the engine, shift the select lever to the "P" position, switch the push-button ignition switch to "OFF" and exit the vehicle.</li> </ul>
Ding	—	—	The battery of the access key fob is low.	Replace the battery of the access key fob.
Ding	—	Flashes in green (15 seconds max.)	<b>Steering lock warning:</b> The engine start procedure was performed, but the steering is still locked.	While turning the steering wheel right and left lightly, depress the brake pedal and press the push-button ignition switch.
Ding	—	Flashes in orange	<b>System malfunction warning:</b> A malfunction was detected in the power system or steering lock.	Contact a SUBARU dealer immediately and have the vehicle inspected.

#### NOTE

An electronic chirp will sound while the select lever is in the "R" position. In this case, the select lever position warning chime will not sound.



## ■ Security indicator light

This indicator light shows the status of the alarm system. It also indicates operation of the immobilizer system.

### ▼ Alarm system

It blinks to show the driver the operational status of the alarm system. For detailed information, refer to “Alarm system” 2-24.

### ▼ Immobilizer system

The security indicator light starts blinking in the following conditions.

#### For models with “keyless access with push-button start system”:

- Immediately after turning the push-button ignition switch to the “OFF” position.
- Immediately after opening or closing the driver’s door when all of the following conditions are met.
  - The push-button ignition switch is in the “ON” or “ACC” position.
  - The engine is not running.
  - In the event that an unauthorized key is used (for example, the key is unregistered or the ID code does not match), the power is not switched to “ON” and the security indicator light continues blinking.

#### For models without “keyless access with push-button start system”:

- Approximately 60 seconds after turning the ignition switch from the “ON” position to the “ACC” or “LOCK” position.
- Immediately after pulling out the key.

If the indicator light does not blink in the above conditions, it may indicate that immobilizer system may be malfunctioning. Contact your nearest SUBARU dealer immediately.

In the event that an unauthorized key (for example, an unauthorized duplicate) is used, the security indicator light illuminates. For details about the immobilizer system, refer to “Immobilizer” 2-22.

### NOTE

- **The security indicator light remains off in the following conditions. It means that the matching of the ID code is completed and the immobilizer system is deactivated, and it does not indicate a malfunction.**

#### Models with “keyless access with push-button start system”:

- The engine is running.
- The push-button ignition switch has been turned to the “ON” or “ACC” position and the driver’s

door has not been opened or closed.

#### Models without “keyless access with push-button start system”:

- The engine is running.
- For approximately 60 seconds after the ignition switch is turned from the “ON” position to the “ACC” or “LOCK” position.
- The ignition switch is in the “ON” position.

- **Even if a malfunction occurs, such as the security indicator light flashes irregularly, it will not affect the functionality of the immobilizer system.**

■ SI-DRIVE indicator (if equipped)

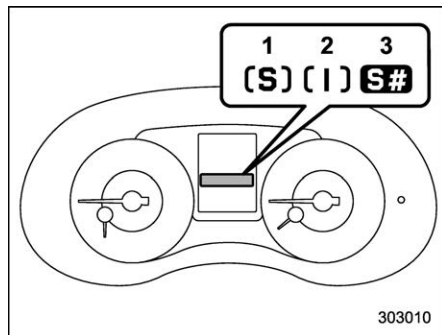

- 1) Sport (S) mode
- 2) Intelligent (I) mode
- 3) Sport Sharp (S#) mode

This indicator shows the current SI-DRIVE mode.

For details of SI-DRIVE mode, refer to “SI-DRIVE” 7-28.

■ Gear position indicator (MT models)/Shift-up indicator (STI)

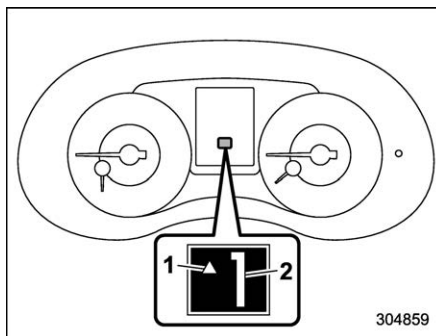

- 1) Shift-up indicator (STI)
- 2) Gear position indicator

The gear position indicator shows the position of the shift lever.

While driving, the shift-up indicator appears and informs the driver about the upshift timing for fuel-efficient driving.

The shift-up indicator can be activated or deactivated.

Refer to “Gear Position Indicator Setting (MT models)” 3-43.

■ Select lever/gear position indicator (CVT models)

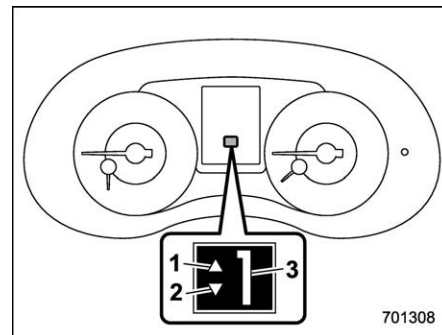

- 1) Upshift indicator
- 2) Downshift indicator
- 3) Select lever/gear position indicator

This indicator shows the position of the select lever.

When the manual mode is selected, the gear position indicator (which shows the current gear selection) and the upshift/downshift indicator light up. Refer to “Continuously variable transmission” 7-23.

While the Sport Sharp (S#) mode is selected, the select lever/gear position indicator remains on and the upshift/downshift indicators is off. However, while

using the manual mode with the Sport Sharp (S#) mode selected, the upshift/downshift indicators will be on.

### ■ Turn signal indicator lights

These lights show the operation of the turn signal or lane change signal.

If the indicator lights do not blink or blink rapidly, the turn signal bulb may be burned out. Replace the bulb as soon as possible. Refer to “Replacing bulbs” 11-44.

### ■ High beam indicator light

This light shows that the headlights are in the high beam mode.

This indicator light also illuminates when the headlight flasher is operated.

### ■ High Beam Assist indicator light (if equipped)

This light illuminates when the High Beam Assist function is activated. For details about the High Beam Assist function, refer to “High beam assist function (models with the EyeSight system)” 3-67.

### ■ Cruise control indicator

This indicator appears when the cruise control main button is pressed to activate the cruise control function. For details, refer to “To set cruise control” 7-53.

If this light blinks, do not use the cruise control. In addition, if it blinks frequently, contact your SUBARU dealer for an inspection.

**⚠ CAUTION**

**If the CHECK ENGINE warning light/malfunction indicator light illuminates, the cruise control indicator flashes at the same time. At this time, avoid driving at high speed and have your vehicle inspected at a SUBARU dealer as soon as possible.**

### ■ Cruise control set indicator

This indicator appears when vehicle speed has been set to use the cruise control function. Refer to “To set cruise control” 7-53.

### ■ Automatic headlight beam leveler warning light (models with LED headlights)

This light illuminates when the automatic headlight beam leveler does not operate normally.



If this light illuminates while driving or does not turn off approximately 3 seconds after turning the ignition switch to the “ON” position, have your vehicle inspected at your SUBARU dealer.

### ■ Front fog light indicator light (if equipped)

This indicator light illuminates while the front fog lights are illuminated.

### ■ Headlight indicator light

This indicator light illuminates under the following conditions.

- The light switch is turned to the “” or “” position.
- The light control switch is in the “AUTO” position and the headlights illuminate automatically.

### ■ Driver's control center differential auto indicator (STI)

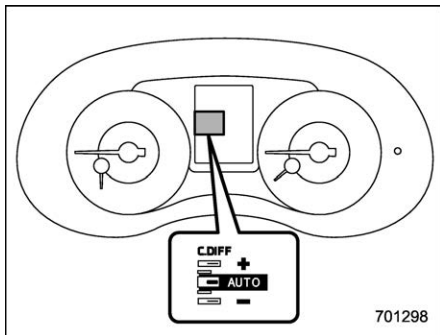

701298

This indicator functions while the ignition switch is "ON". When it appears, it indicates that the driver's control center differential is set to the auto mode. It disappears when the driver's control center differential is set to the manual mode. For details, refer to "Driver's Control Center Differential (C.DIFF/DCCD) (STI)" 7-19.

### ▼ Driver's control center differential auto [+] indicator (STI)



When the AUTO [+] mode is set, the AUTO [+] indicator appears.

For details, refer to "Driver's Control Center Differential (C.DIFF/DCCD) (STI)"

7-19.

### ▼ Driver's control center differential auto [-] indicator (STI)



When the AUTO [-] mode is set, the AUTO [-] indicator appears.

For details, refer to "Driver's Control Center Differential (C.DIFF/DCCD) (STI)"

7-19.

### ■ Driver's control center differential indicator and warning (STI)

#### ▼ Indicator

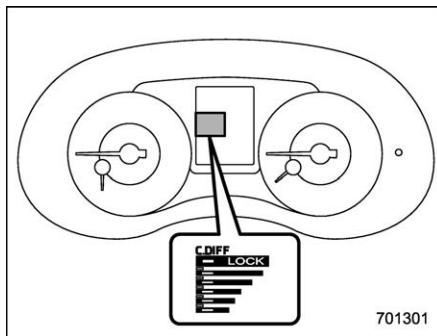

701301

When you select the manual mode of the driver's control center differential, these indicators will appear. They indicate the

initial limited slip differential (LSD) torque that is currently selected for the center differential.

#### ▼ Warning indicator

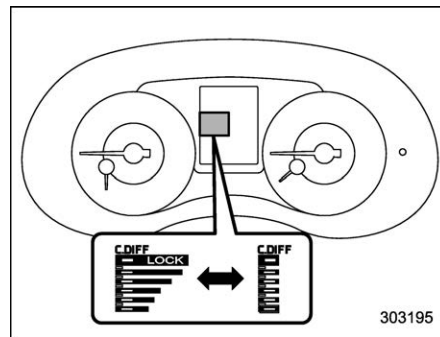

303195

All the indicators will flash when the driver's control center differential has a malfunction. Have the vehicle inspected by your SUBARU dealer. For details, refer to "Driver's Control Center Differential (C.DIFF/DCCD) (STI)" 7-19.

If a malfunction occurs in the vehicle (for example, when the rear differential oil becomes hot), all of the indicators may disappear. In this case, the setting value for the initial limited slip differential (LSD) torque of the driver's control center differential (C.DIFF/DCCD) will be cancelled. However, it does not indicate a malfunction of the C.DIFF/DCCD itself.

### ■ REV indicator light (STI)

This indicator light illuminates when the engine speed reaches the level that was previously set. This indicator light also flashes when the tachometer needle enters the red zone. For details, refer to “REV indicator light and buzzer (STI)” 3-12.

### ■ Steering Responsive Headlight warning indicator/Steering Responsive Headlight OFF indicator (if equipped)

**SRH  
OFF**

This indicator appears when the Steering Responsive Headlight is deactivated. Also, the indicator flashes when a malfunction occurs in the Steering Responsive Headlight. Refer to “Steering Responsive Headlight (SRH)” 3-71.

### ■ BSD/RCTA warning indicator (if equipped)

This warning indicator appears when the BSD/RCTA is malfunctioning. In this case the BSD/RCTA warning indicator will be shown on the combination meter display (color LCD). When this indicator appears, have your vehicle inspected by your SUBARU dealer as soon as possible.

### ■ BSD/RCTA OFF indicator (if equipped)

The indicator appears when the BSD/RCTA is deactivated. In this case the BSD/RCTA OFF indicator will be shown on the combination meter display (color LCD). For details, refer to “BSD/RCTA” 7-56.

### ■ RAB warning indicator (if equipped) **RAB**

This indicator illuminates if the Reverse Automatic Braking (RAB) system malfunctions. Refer to “Reverse Automatic Braking (RAB) system” 7-66.

### ■ RAB OFF indicator (if equipped) **RAB OFF**

This indicator illuminates when the Reverse Automatic Braking (RAB) system is turned OFF, or when the Reverse Automatic Braking (RAB) system is suspended temporarily. Refer to “Reverse Automatic Braking (RAB) system” 7-66.

## Combination meter display (color LCD)

### **WARNING**

**Always pay adequate attention to safe driving when operating the combination meter display (color LCD) while the vehicle is in motion. When operation of the combination meter display (color LCD) interferes with your ability to concentrate on driving, stop the vehicle before performing operations on the screen. Also, do not concentrate on the display while driving. Doing so may cause you to look away from the road and could result in an accident.**

Various information will be shown on the combination meter display (color LCD). Also, a warning message will appear on the display if a malfunction, etc. is detected. In addition, several settings for the displayed content can be performed.

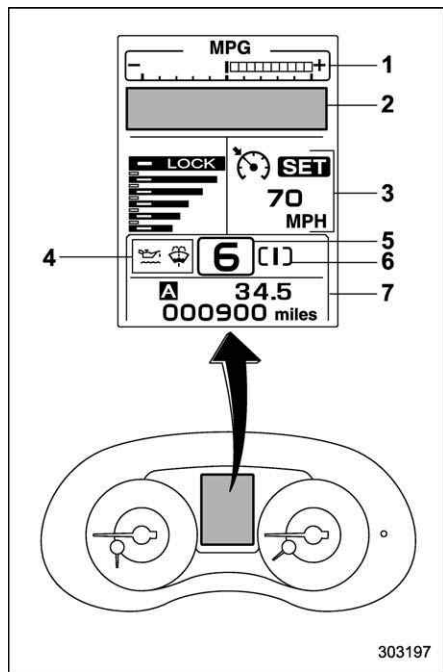

303197

**Combination meter display (color LCD)**

- 1) ECO gauge (Refer to “ECO gauge” ¶3-12.)
- 2) Warning screen (Refer to “Warning screen” ¶3-39.)/Basic screen (Refer to “Basic screens” ¶3-39.)
- 3) Cruise control information display/ C.DIFF/DCCD indicator

- 4) Warning indication (Refer to “Warning indication” ¶3-40.)
- 5) Select lever/gear position indicator (Refer to “Select lever/gear position indicator (CVT models) ¶3-34./Gear position indicator (MT models)/Shift-up indicator (STI) (Refer to “Gear position indicator (MT models)/Shift-up indicator (STI)” ¶3-34.)
- 6) SI-DRIVE indicator (Refer to “SI-DRIVE indicator” ¶3-34.) (if equipped)
- 7) Odometer (Refer to “Odometer” ¶3-9.)/ Double trip meter (Refer to “Double trip meter” ¶3-9.)

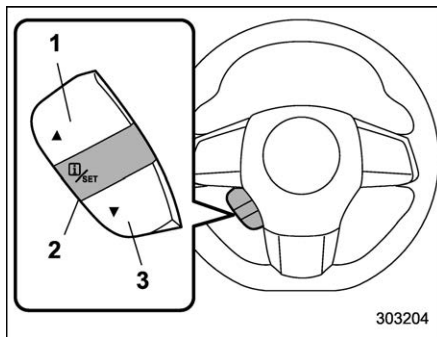

303204

**Control switch**

- 1) Up (select)
- 2) /SET (enter)
- 3) Down (select)

**Basic operation**

Pull “▲” or “▼” of the control switch toward you to switch the screens and selection items. Pull the “/SET” switch toward you to select and set the item.

If there are some useful messages, such as vehicle information, warning information, etc., they will interrupt the current screen, and appear on the display accompanied by a beep. If such a screen is displayed, take proper action according to the message shown on the screen.

The warning screen will return to the original screen after a few seconds. While the “” information reminder is shown on the display, it may be possible to display the warning screen again. To recall the message marked with “” on the display, pull the “/SET” switch toward you.

## ■ Welcome screen (opening animation) and Good-bye screen (ending animation)

When the driver's door is opened and closed after unlocking the door, the Welcome screen (opening animation) will appear on the combination meter display (color LCD) for approximately 20 seconds. When the ignition switch is turned to the "LOCK"/"OFF" position, the combination meter display (color LCD) gradually turns off while showing the Good-bye screen (ending animation).

### NOTE

- The welcome screen and the good-bye screen may differ in the actual words and appearance.
- Once the Welcome screen appears, it takes a certain period of time to display it again.
- The Welcome screen will disappear after turning the ignition switch to the "ON" position while the Welcome screen is displayed.
- If you open any of the doors while the Welcome screen is displayed, the door ajar warning will appear.
- You can set the Welcome screen and Good-bye screen to on or off. For details, refer to "Welcome Good-bye Screen" 3-43.

## ■ Warning screen

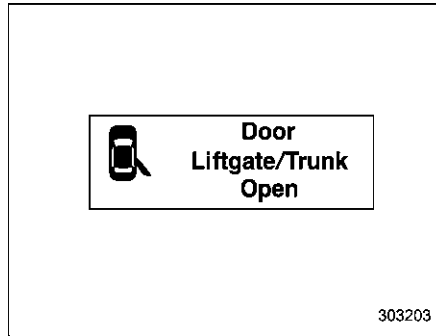

Example of warning

If a warning or a malfunction is detected, a message will appear. Take the appropriate actions based on the messages indicated.

## ■ Basic screens

Pull the "▲" or "▼" switch on the steering wheel to change the screen that is always displayed.

Default screen:

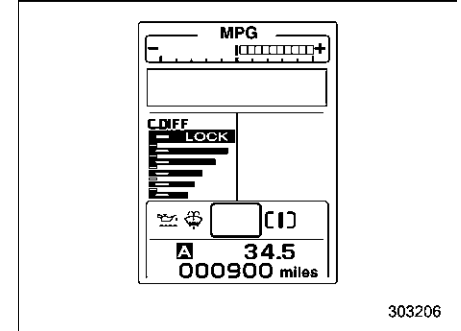

Journey time screen:

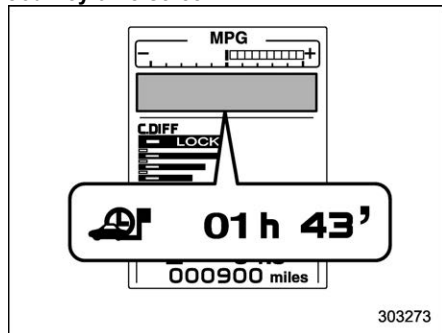

303273

This screen displays the journey time (the time that has elapsed since the ignition switch was turned to the “ON” position).

Digital speedometer:

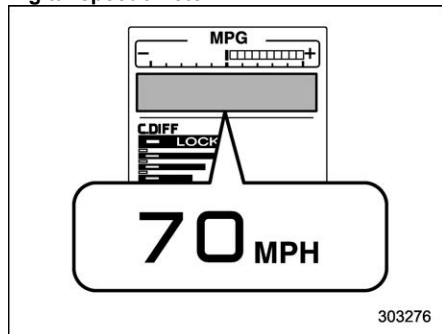

303276

SI-DRIVE mode screen (if equipped):

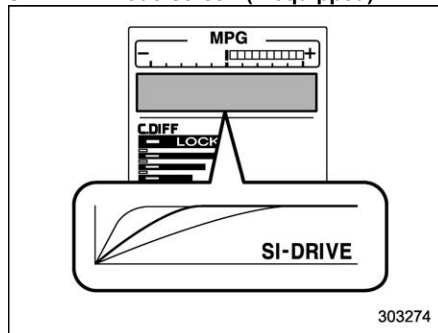

303274

This screen indicates the current SI-DRIVE mode with its throttle angle.

Menu screen entering screen:

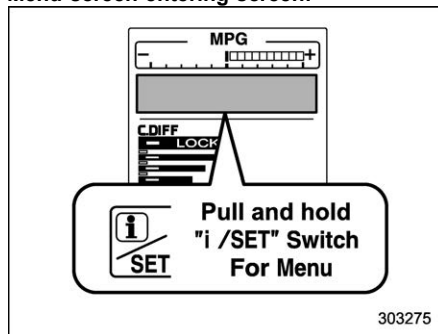

303275

While this screen is selected, pull and hold the “i/SET” switch to enter the menu

screen.

Warning indication

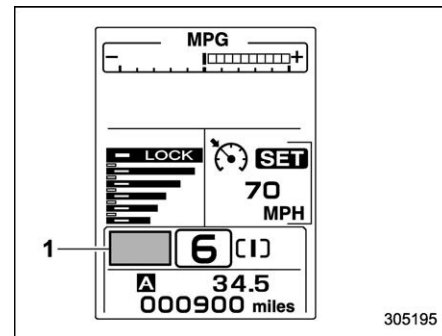





305195

1) Warning indication

When the corresponding situation occurs, the following warning indications will be displayed.



Mark	Name	Page
	Engine low oil level warning indicator (except STI)	3-17
	BSD/RCTA warning indicator (if equipped)	3-37
	BSD/RCTA OFF indicator (if equipped)	3-37
<b>SRH OFF</b>	Steering Responsive Headlight OFF indicator (if equipped)	3-37
	Windshield washer fluid warning indicator	3-18, 3-76, 11-38
	Access key warning indicator (if equipped)	3-28
<b>RAB</b>	RAB warning indicator (if equipped)	3-37
<b>RAB OFF</b>	RAB OFF indicator (if equipped)	3-37

## ■ Menu screens

Pull and hold the “/SET” switch to enter the menu screens when all of the following conditions are satisfied.

- The vehicle has been completely stopped.
- The select lever is in the “P” position (CVT models).
- The shift lever is in the neutral position (MT models).
- The menu screen entering screen is selected.

Pull the “▲” or “▼” switch to select the menu. Pull the “/SET” switch to enter the selected menu.

## NOTE

**If you enter the “Go Back” menu, the system will return to the previous screen.**

### 3-42 Instruments and controls/Combination meter display (color LCD)

The menu list is as follows.

Top menu	Menu option	Possible settings	Initial settings	
Screen Settings	Welcome Good-bye Screen	On/Off	On	
	Gauge Initial Movement	On/Off	On	
	Gear Position Indicator Setting (MT models)	On/Off	On	
	Languages	Select the display language.	The default language settings vary depending on individual countries. (For U.S. models: English)	
SRH (if equipped)	—	On/Off	On	
REV setting (STI)	REV Indicator Light	On/Off	Off	
	REV Alarm Level Engine Speed	2000 rpm - RED ZONE	2000 rpm	
	REV Buzzer	On/Off	Off	
EyeSight (models with the EyeSight system)	Warning Volume	Max/Mid/Min	Mid	
	Lead Vehicle Acquisition Sound	On/Off	On	
	Lead Vehicle Moving Monitor Function	On/Off	On	
	EyeSight Assist Monitor	EyeSight Assist Monitor Red Indicator	On/Off	On
		EyeSight Assist Monitor Yellow Indicator	On/Off	On
EyeSight Assist Monitor Green Indicator		On/Off	On	
BSD/RCTA (if equipped)	Warning Volume	Max/Mid/Min/Off	Mid	
RAB (models with the EyeSight system)	Warning Volume	Max/Mid/Min	Mid	
	Sonar Audible Alarm	On/Off	On	
Default Settings	—	Yes/No	—	

**▼ Screen Settings**

After entering the “Screen Settings” menu, select one of the following menus.

**▽ Welcome Good-bye Screen**

The welcome screen/good-bye screens can be activated or deactivated. Select “On” to activate the screens. Select “Off” to deactivate the screens.

**▽ Gauge Initial Movement**

The movement of the meter needles and gauge needles that occurs when the ignition switch is turned to the “ON” position can be activated or deactivated. Select “On” to activate. Select “Off” to deactivate.

**▽ Gear Position Indicator Setting (MT models)**

Display of the shift position indicator can be activated or deactivated. Select “On” to activate display of the shift position indicator or “Off” to deactivate it.

**▽ Languages**

Operate the “▲” or “▼” switch on the steering wheel to display the preferred language. Then pull the “/SET” switch to select the displayed language.

**▼ SRH (if equipped)**

Select “On” to activate the Steering Responsive Headlight (SRH). Select “Off” to deactivate the SRH.

**▼ REV setting (STI)****NOTE**

**If the setting of the REV Indicator Light is “Off”, the setting menus of the REV Alarm Level Engine Speed and the REV Buzzer are not displayed.**

After entering the “REV setting” menu, select any of the following menus.

**▽ REV Indicator Light**

Display of the REV indicator light can be activated or deactivated. Select “On” to activate display of the REV indicator light or “Off” to deactivate it.

**▽ REV Alarm Level Engine Speed**

The alarm-level engine speed can be set (in 100 rpm steps) within the range from 2,000 rpm to the red zone.

**▽ REV Buzzer**

The REV buzzer can be activated or deactivated. Select “On” to activate the REV buzzer or “Off” to deactivate it.

**▼ EyeSight (models with the EyeSight system)****NOTE**

**Refer to the Owner’s Manual supplement for the EyeSight system.**

**▼ BSD/RCTA (if equipped)**

After entering the “BSD/RCTA” menu, select the “Warning Volume” menu. You can set the volume of the warning buzzer for RCTA (Rear Cross Traffic Alert). You can select “Max”, “Mid”, “Min” or “Off”.

**▼ RAB (models with the EyeSight system)**

After entering the “RAB” menu, select one of the following menus.

**NOTE**

**For details about the Reverse Automatic Braking (RAB) system, refer to “Reverse Automatic Braking (RAB) system”  7-66.**

**▽ Warning Volume**

The volume of the warning sound that is activated when the Reverse Automatic Braking (RAB) system is in operation can be set in 3 stages (“Max”, “Mid” and “Min”).

▽ **Sonar Audible Alarm**

The Reverse Automatic Braking (RAB) system is equipped with a function that emits a warning sound when the system operates. The function can be activated or deactivated. Select “On” to set the warning sound to active. Select “Off” to set the warning sound to inactive.

▼ **Default Settings**

Select “Yes” to use the menu screen to restore customized settings to the factory default settings. Select “No” to return to the previous screen without restoring to the factory default settings.

**Multi-function display (color LCD)**



**Always pay adequate attention to safe driving when operating the multi-function display while the vehicle is in motion. When operation of the multi-function display is disturbing your awareness and ability to concentrate on driving, stop the vehicle in a safe place before performing operations on the screen. Also, do not concentrate on the display while driving. Doing so may cause you to look away from the road and could result in an accident.**

The multi-function display has the following functions.

Description	Page
Displays useful messages, such as warning information, etc.	3-46
Displays basic screens (e.g. fuel consumption screen, etc.)	3-47
Sets and adjusts maintenance notification	3-58
Registers driving history	3-60
Sets and customizes car operation	3-61
Reverse Automatic Braking (RAB) system (if equipped)	7-66

Also, use the multi-function display to set and initialize the multi-function display itself.

**NOTE**

- **Illustrations show the display for U.S.-spec. models as an example. For models other than U.S.-spec. models, elements in the illustrations (such as the display indication and measurement unit) may be different than the ones for U.S.-spec. models.**
- **When the vehicle is in motion, certain functions and selections may not be available.**
- **The images shown in this Owner’s Manual are sample images. The actual images may vary depending on the**

market and vehicle specifications.

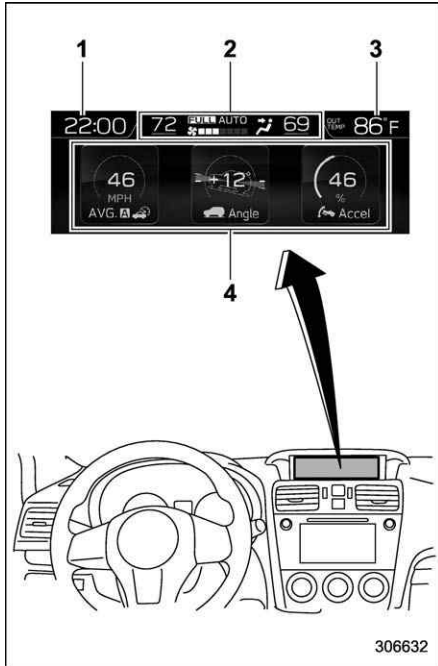

#### Multi-function display

- 1) Clock
- 2) Climate control (displayed only when the ignition switch is in the "ON" position)
- 3) Outside temperature
- 4) Information screen

### NOTE

- The outside temperature indicator shows the temperature around the sensor. However, the temperature may not be indicated correctly or the update may be delayed in the following conditions.

- While parking or driving at low speeds
- When the outside temperature changes suddenly (example: when going in and out of an underground parking area or when passing through a tunnel)
- When starting the engine after being parked for a certain period of time

### ■ Welcome screen

When the driver's door is closed, the welcome screen will appear for a short time.

### NOTE

- The welcome screen will disappear when the ignition switch is turned to the "ON" position while the welcome screen is displayed.
- You can set the welcome screen to on or off. For details, refer to "Bypass screen setting" 3-57.

- For a certain period of time after the welcome screen has once appeared, it may not appear again even when the driver's door is closed again. This does not indicate a malfunction.

### ■ Self-check screen

When the ignition switch is turned to the "ON" position, the vehicle self-check will be performed. The screens corresponding to the following items will appear one after another for several seconds each.

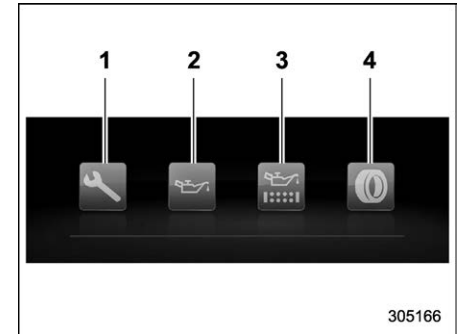

- 1) Inspection and maintenance: Checks the interval of inspection and maintenance.
- 2) Engine oil: Checks the interval of engine oil replacement.
- 3) Oil filter: Checks the interval of oil filter replacement.
- 4) Tires: Checks the interval of tire rotation.

When the checks are performed, the color of the icon corresponding to the checked item will turn as follows:

- If the checked item has no notifications, it turns green.
- If the checked item has any maintenance notifications, it turns yellow.

If there is a notification, the message will be displayed. Take the appropriate actions based on the message indicated.

**NOTE**

- You can set the self-check screen to on or off. The default setting is off. For details, refer to “On/Off setting” 3-59.
- After performing the maintenance, change the setting of the corresponding maintenance item. For details, refer to “Maintenance settings” 3-58.
- The maintenance notification screen will be displayed under either of the following conditions.
  - The period of time remaining until the registered notification date is 15 days or less.
  - The total driving distance remaining until the registered notification distance is approximately 311 miles (500 km) or less.
- The maintenance notification screen will be displayed until either of the following conditions is satisfied.

- The period of time passed after the registered notification date is 15 days or more.
- The total distance driven after the registered notification distance is approximately 311 miles (500 km) or more.

**■ Interruption screen**

Useful messages, such as reminder information, vehicle information, warning information, etc. may interrupt the current screen and appear on the display accompanied by a beep. Take proper action according to the message.



The warning screen will return to the original screen after a few seconds.

**■ Basic operation**

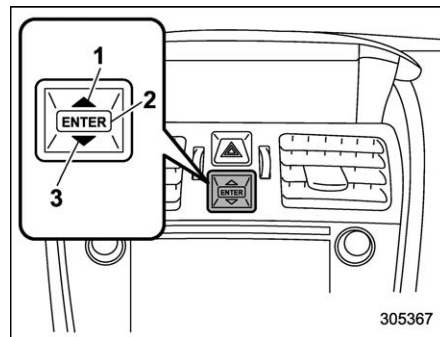

Control switch (type A)

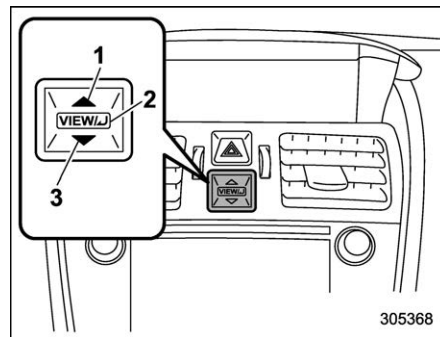

Control switch (type B)

- 1) Up (select)
- 2) ENTER (push)
- 3) Down (select)

By operating “▲” or “▼” of the control switch, the screens and selection items can be switched. When the ENTER button is pushed, the item can be selected and set.

## ■ Basic screens

### ▼ Climate control screen

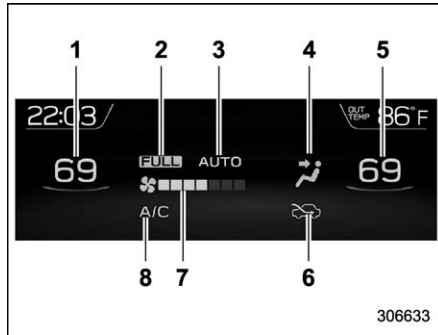

#### Climate control screen

- 1) Set temperature indicator (left-hand side)
- 2) FULL AUTO indicator
- 3) AUTO indicator
- 4) Airflow mode indicator
- 5) Set temperature indicator (right-hand side)
- 6) Air inlet selection indicator
- 7) Fan speed indicator
- 8) Air conditioner ON indicator

When operating the climate control system, the basic screen will change to the climate control screen. For details about the climate control system, refer to “Climate control” 4-1.

### ▼ Information screen

Operate the “▲” or “▼” of the control switch to select the screen that is always displayed on.

Content	Description	Page
Fuel consumption screen	Displays fuel consumption screen.	3-48
Triple meter screen	Displays up to 3 optional items.	3-49
Prevention safety screen	Displays the status of your vehicle.	3-49
Boost pressure screen	Displays the boost pressure, etc.	3-50
Guidance screen	Enters the setting screen	3-50
Clock/calendar screen	Displays the clock/calendar.	3-51

#### ▽ Fuel consumption screen

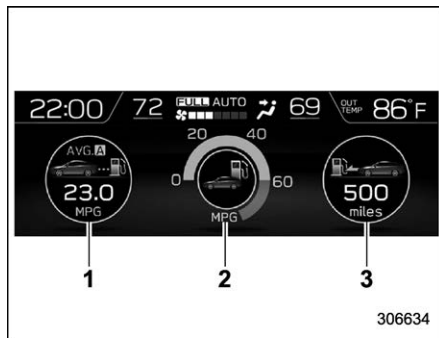

- 1) Average fuel consumption corresponding to the driving distance of each trip meter
- 2) Current fuel consumption
- 3) Driving range on remaining fuel

#### NOTE

The driving range on the remaining fuel is only a guide. The indicated value may differ from the actual driving range on the remaining fuel, so you must immediately fill the tank when the low fuel warning light illuminates.



▽ Triple meter screen



**Triple meter screen (display example)**

From the following pieces of information, you can select up to three items to be displayed.

Item	Details
	Engine oil temperature (except STI)
	Average vehicle speed
	Accelerator opening ratio

Item	Details
	Vehicle posture
	Average fuel consumption for the entire driving distance from when the ignition switch was turned to the "ON" position
	Boost pressure
	Journey distance (the distance that has been driven since the ignition switch was turned to the "ON" position)
	Average fuel consumption corresponding to the driving distance of the odometer
	Nothing is displayed.

▽ Prevention safety screen

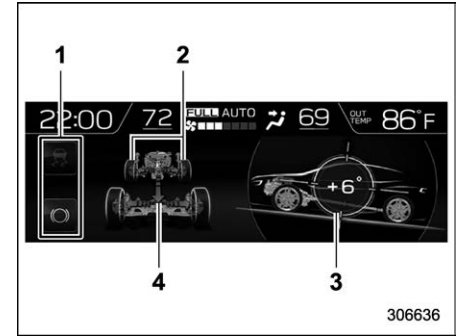

- 1) Telltale screen
- 2) Steering angle
- 3) Vehicle posture
- 4) Running condition

For functions that are operating, the corresponding indicator will illuminate or flash.

**NOTE**

**The vehicle posture indication may differ from the actual vehicle posture.**

▽ Boost pressure screen

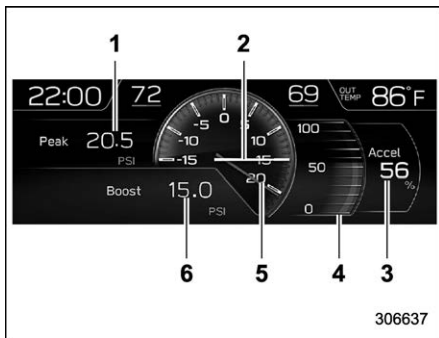

- 1) The peak value of the boost pressure (digital display)
- 2) Boost pressure (analog display)
- 3) Accelerator opening ratio (digital display)
- 4) Accelerator opening ratio (analog display)
- 5) The peak value of the boost pressure (analog display)
- 6) Boost pressure (digital display)

You can reset the peak value of the boost pressure. Press and hold the ENTER button to enter the reset screen.

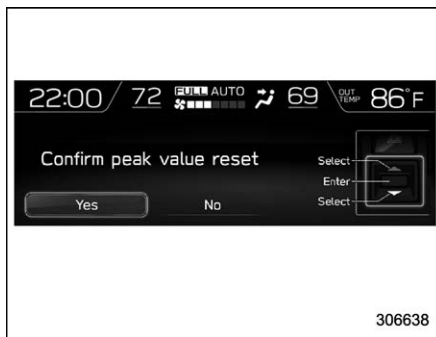

Select "Yes" to reset the peak value. Select "No" to keep the current peak value.

▽ Guidance screen



**Guidance screen (display example)**

Press and hold the ENTER button to enter the setting screen. For details, refer to "Setting screen" 3-52.

▽ **Clock/calendar screen**



**Clock**

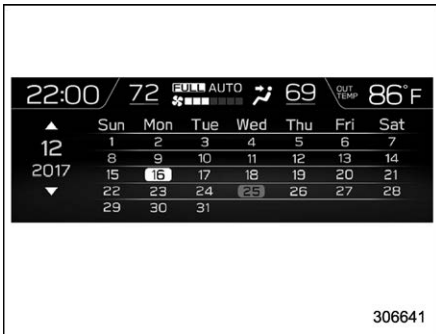

**Calendar**

You can select the clock or calendar to be displayed. You can also turn the screen off. For the setting procedure, refer to “Clock setting” 3-57.

## ■ Setting screen

Push and hold the ENTER button to display the setting screen. Select the preferred menu by operating the “▲” or “▼” switch.

### Items that can be set when stopped:

Top menu	Menu option	Description	Page	
Time/Date	Date	Set and adjust the date. 12h or 24h format can be selected.	3-55	
	Birthday	Set a birthday. (max. 5)	3-55	
	Anniversary	Set an anniversary day. (max. 5)	3-55	
	Daylight Saving Time	Turn the daylight saving time on or off.	3-55	
	Go Back	Return to the top menu.	—	
Display	Contrast	Adjust the contrast.	+5 ↔ -5	3-56
	Screen Off	Turn the screen off.		3-56
	Beep	Adjust the beep sound volume.	High/Low/Off	3-56
	Go Back	Return to the top menu.		—
Screen Setting	Triple Meter	Set and customize the triple meter.		3-57
	Clock	Select the clock format.	Analog Clock/Calendar/Off	3-57
	Bypass Screen	Set the bypass screen for each item.	On/Off	3-57
	Languages	Select the display language.	English or French or Spanish (U.S.-spec. models only)	3-58
	Camera Shift Link <sup>*1</sup>	Set the front view monitor.	On/Off	3-58
	Go Back	Return to the top menu.		—

Top menu	Menu option	Description	Page	
Maintenance	Maintenance Schedule	Set and adjust the vehicle maintenance notification date.	3-59	
	Engine Oil	Set and adjust the oil maintenance notification date.	3-58	
	Oil Filter	Set and adjust the oil filter maintenance notification date.	3-59	
	Tires	Set and adjust the tire maintenance notification date.	3-59	
	On/Off	Turn on or off the self-check screen that is activated when the ignition switch is turned to the "ON" position.	On/Off	3-59
	Clear All Settings	Clear all items to the factory default settings.	Yes/No	3-60
	Go Back	Return to the top menu.		—
Driving History	Set	Register and overwrite the driving record.	3-60	
	Go Back	Return to the top menu.	—	
Car Setting	Keyless Buzzer Volume	Set the audible signal volume.	0 (Off) to 7	3-61
	Hazard Warning Flasher	Set the hazard warning flasher.	On/Off	3-61
	Defogger	Set and customize the operation of the defogger.	15 minutes/Continuous	3-61
	Interior Light	Set and customize the interior light off delay timer.	10, 20, 30 seconds/Off	3-62
	Auto Light Sensor*1	Set and customize the sensitivity of the auto light sensor.	Low/Mid/High/Max	3-62
	Keyless Access Settings*1	Set and customize the keyless access function.	Driver's Door Only/All	3-62
	Welcome Lighting	Set the leaving time and approaching time.	30, 60, 90 seconds/Off	3-62
	Go Back	Return to top menu.		—
Initialize	Reset to Defaults	Reset all settings to the default settings.	Yes/No	3-63
	Lifetime Fuel Cons Reset	Clear logged lifetime fuel consumption data.	Yes/No	3-63
	Go Back	Return to the top menu.		—
Go Back	—	Return to the top menu.	—	

\*1: If equipped

### 3-54 Instruments and controls/Multi-function display (color LCD)

#### Items that can be set while driving:

Menu	Description		Page
Contrast	Adjust the contrast.	+5 ↔ -5	3-56
Screen Off	Turn the screen off.		3-56
Beep	Adjust the beep sound volume.	High/Low/Off	3-56
Time	Set and adjust the time (only hour).		3-55
Daylight Saving Time	Turn the daylight saving time on or off.	On/Off	3-55
Defogger	Set and customize the operation of the defogger.	15 minutes/Continuous	3-61
Go Back	Return to the top menu.		—

For safety reasons, we recommend stopping the vehicle in a safe location while setting.

▼ **Date and time settings**

If a birthday or anniversary is approaching, a message will be displayed when turning the ignition switch to the “ON” position. You can set this function to on or off. For details, refer to “Bypass screen setting” 3-57.

▼ **Current date and time setting**

For details about clock setting, refer to “Clock” 3-64.

▼ **Birthday setting**

1. Select “Birthday” from the 2nd menu in the setting screen. Refer to “Setting screen” 3-52.



2. Select from the list the number that you want to register.



3. Enter the date and the text by using the control switches.  
 4. Select “Set” to exit settings. Select “Go Back” to return to the previous screen without applying the setting changes.

**NOTE**

**You can store a maximum of 5 birthdays.**

▼ **Anniversary setting**

The setting procedure is the same as “Birthday setting” 3-55, but select the “Anniversary” item in step 1.

**NOTE**

**You can store a maximum of 5 anniversaries.**

▼ **Daylight saving time setting**

1. Select “Daylight Saving Time” from the 2nd menu in the setting screen. Refer to “Setting screen” 3-52.



2. Select “On” or “Off” by using the control switches.  
 3. Select “Set” to exit settings. Select “Go Back” to return to the previous screen without applying the setting changes.

### ▼ Display/Beep settings

You can set the display settings and volume settings.

#### ▽ Contrast setting

1. Select “Contrast” from the 2nd menu in the setting screen. Refer to “Setting screen” 3-52.

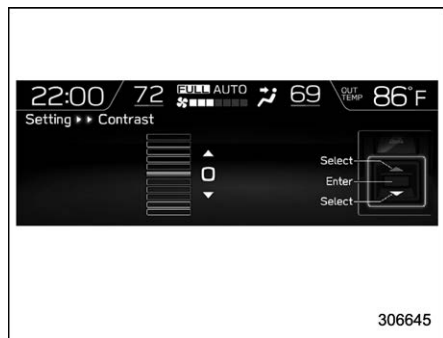

2. Select the contrast level by using the control switches.
3. Press the ENTER button to confirm the setting.

#### ▽ Screen OFF setting

1. Select “Screen Off” from the 2nd menu in setting screen. Refer to “Setting screen” 3-52.

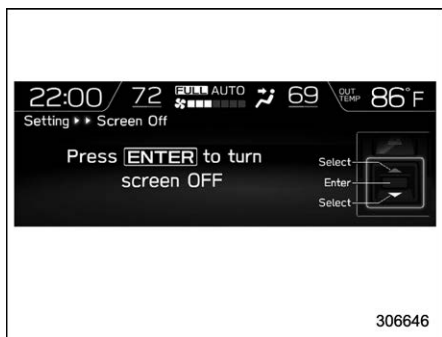

2. Press the ENTER button to turn off the screen.

### Restoring the screen

When operating the control switches with the ignition switch in the “ON” or “ACC” position, the screen will be restored. The screen will be restored with the basic screen that was displayed when the screen was turned off.

### NOTE

**While the screen is off, the screen switches to the climate control screen only when the air conditioner is operating.**

### ▽ Beep setting

1. Select “Beep” from the 2nd menu in the setting screen. Refer to “Setting screen” 3-52.

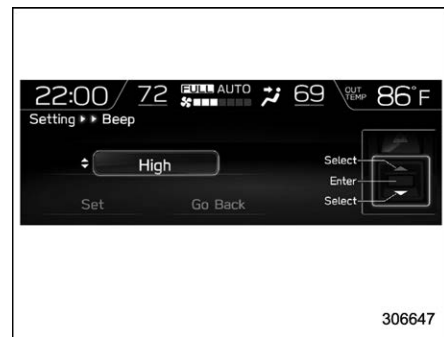

2. Set the beep volume by using the control switches.
3. Select “Set” to exit settings. Select “Go Back” to return to the previous screen without applying the setting changes.



## ▼ Screen settings

### ▽ Triple meter setting

1. Select the “Triple Meter” from the 2nd menu in setting screen. Refer to “Setting screen” 3-52.

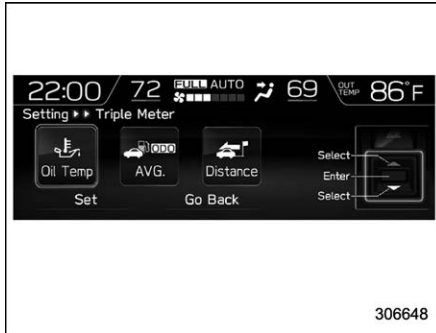

2. Set the desired items by using the control switches. For details about items, refer to “Triple meter screen” 3-49.

3. Select “Set” to exit settings. Select “Go Back” to return to the previous screen without applying the setting changes.

## NOTE

- You can display a maximum of the 3 items.
- The same item cannot be selected for the left, center or right location.

### ▽ Clock setting

1. Select “Clock” from the 2nd menu in the setting screen. Refer to “Setting screen” 3-52.

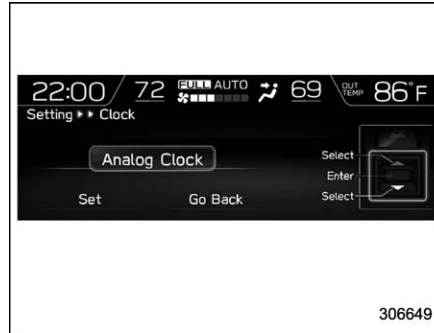

2. Select “Analog Clock”, “Calendar” or “Off” by using the control switches.

3. Select “Set” to exit settings. Select “Go Back” to return to the previous screen without applying the setting changes.

### ▽ Bypass screen setting

1. Select “Bypass Screen” from the 2nd menu in the setting screen. Refer to “Setting screen” 3-52.

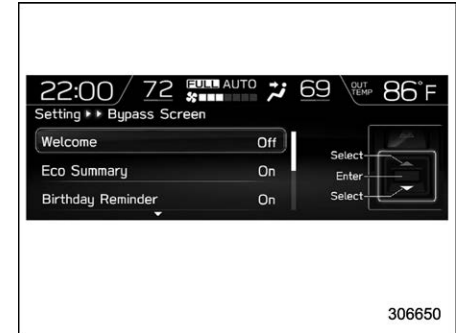

2. Select “On” or “Off” to turn the display of items on or off by using the control switches.

3. Select “Set” to exit settings. Select “Go Back” to return to the previous screen without applying the setting changes.

▽ **Language setting**

1. Select “Languages” from the 2nd menu in the setting screen. Refer to “Setting screen” 3-52.



2. Select the preferred language by using the control switches.
3. Select “Set” to exit settings. Select “Go Back” to return to the previous screen without applying the setting changes.

▽ **Camera shift link setting (if equipped)**

1. Select “Camera Shift Link” from the 2nd menu in the setting screen. Refer to “Setting screen” 3-52.

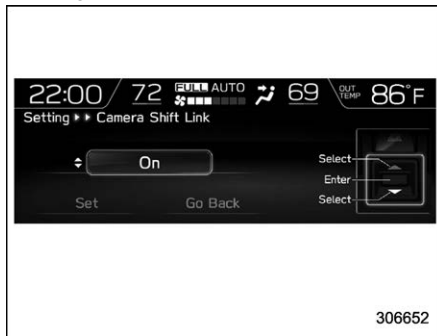

2. Select “On” or “Off” by using the control switches.
3. Select “Set” to exit settings. Select “Go Back” to return to the previous screen without applying the setting changes.

▼ **Maintenance settings**

You can set maintenance reminders.

▽ **Engine oil setting**

1. Select “Engine Oil” from the 2nd menu in the setting screen. Refer to “Setting screen” 3-52.

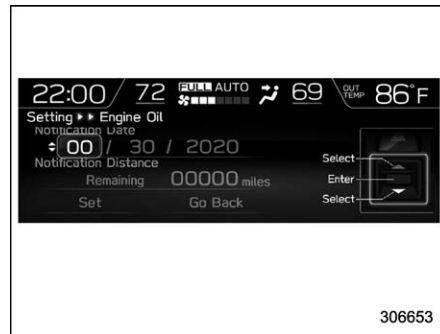

2. Set the date and distance of the reminder by using the control switches.
3. Select “Set” to exit settings. Select “Go Back” to return to the previous screen without applying the setting changes.

**NOTE**

- The reminder will be displayed by either date or distance in accordance with the setting.
- Even when either “Day” or “Distance” are displayed as “\_ \_” a pop-up screen will appear.
- The reminder will be displayed until either of the following conditions is satisfied.
  - The period of time passed after the registered notification date is 15 days or more.
  - The total distance driven after the registered notification distance is approximately 311 miles (500 km) or more.

▽ **Oil filter setting**

The setting procedure is the same as “Engine oil setting” 3-58, but select the “Oil Filter” item in step 1.

▽ **Tires setting**

The setting procedure is the same as “Engine oil setting” 3-58, but select the “Tires” item in step 1.

▽ **Maintenance schedule setting**

The setting procedure is the same as “Engine oil setting” 3-58, but select the “Maintenance Schedule” item in step 1.

▽ **On/Off setting**

1. Select “On/Off” from the 2nd menu on the setting screen. Refer to “Setting screen” 3-52.

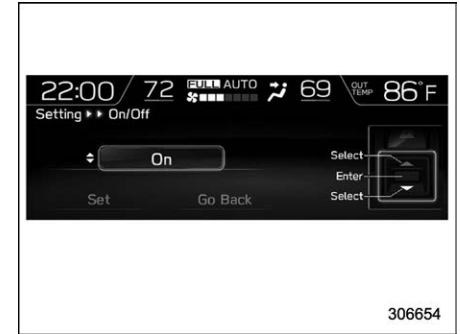

2. Select “On” or “Off” to turn the opening screen on or off by using the control switches.
3. Select “Set” to exit settings. Select “Go Back” to return to the previous screen without applying the setting changes.

#### ▽ Clear setting

1. Select “Clear All Settings” from the 2nd menu on the setting screen. Refer to “Setting screen” 3-52.



2. Select “Set” to clear the settings. Select “Go Back” to return to the previous screen without clearing the settings.

#### ▼ Driving history setting

You can register the items in the driving history.

1. Select “Driving History” from the top menu in the setting screen. Refer to “Setting screen” 3-52.

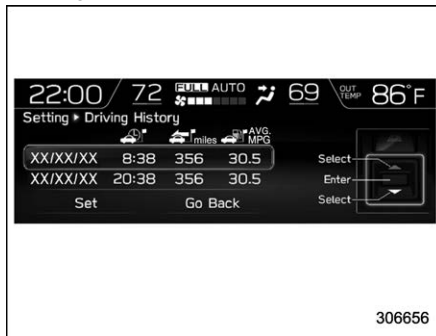

2. Select one of the registration lines by using the control switches.

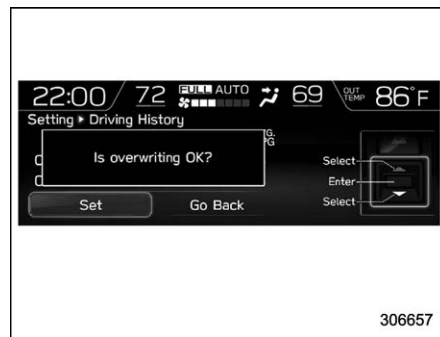

3. Select “Set” to overwrite the previous registration. Select “Go Back” to return to the previous screen without overwriting the previous registration.

**▼ Car setting**

You can set the vehicle setting.

**▼ Keyless buzzer volume setting**

1. Select “Keyless Buzzer Volume” from the 2nd menu in the setting screen. Refer to “Setting screen” 3-52.

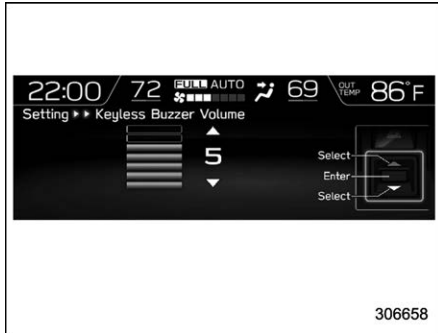

2. Select a volume level by using the control switches.
3. Press the ENTER button to confirm the setting.

**▼ Hazard warning flasher setting**

1. Select “Hazard Warning Flasher” from the 2nd menu in the setting screen. Refer to “Setting screen” 3-52.

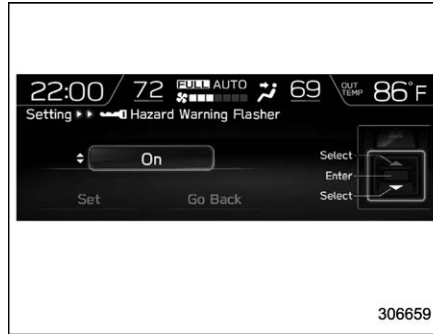

2. Select “On” or “Off” by using the control switches.
3. Select “Set” to exit settings. Select “Go Back” to return to the previous screen without applying the setting changes.

**▼ Defogger setting**

1. Select “Defogger” from the 2nd menu in the setting screen. Refer to “Setting screen” 3-52.

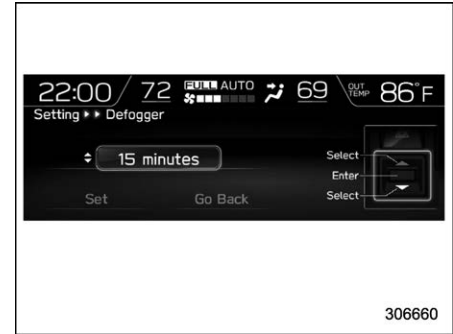

2. Select the preferred setting by using the control switches.
3. Select “Set” to exit settings. Select “Go Back” to return to the previous screen without applying the setting changes.

### ▽ Interior light setting

The setting procedure is the same as “Defogger setting” 3-61, but select the “Interior Light” item in step 1.

### ▽ Auto light sensor setting (if equipped)

The setting procedure is the same as “Defogger setting” 3-61, but select the “Auto Light Sensor” item in step 1.

### ▽ Keyless Access Settings (if equipped)

1. Select “Keyless Access Settings” from the 2nd menu in the setting screen. Refer to “Setting screen” 3-52.
2. Select “Driver’s Door Unlock”.

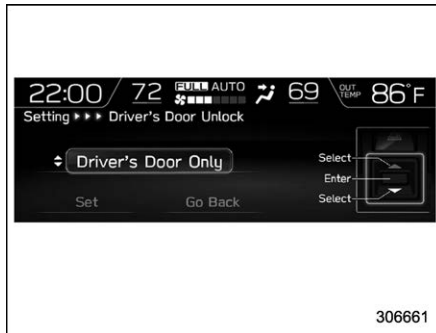

3. Select the preferred setting by using the control switches.
4. Select “Set” to exit settings. Select “Go Back” to return to the previous screen without applying the setting changes.

### ▽ Welcome lighting setting

You can change the setting for the period of time in which the exterior remain on by the welcome lighting function.

1. Select “Welcome Lighting” from the 2nd menu in the setting screen. Refer to “Setting screen” 3-52.
2. Select “Leaving time set” to change the setting when leaving the vehicle. Select “Approaching time set” to change the setting when approaching.

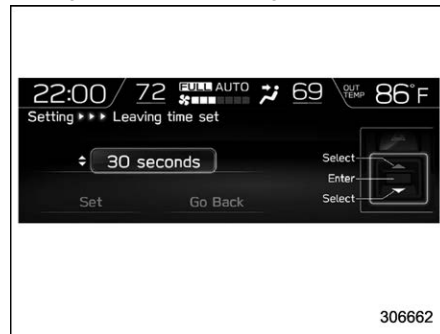

3. Select the preferred setting by using the control switches.
4. Select “Set” to exit settings. Select “Go Back” to return to the previous screen without applying the setting changes.

▼ **Initialize**

You can initialize the items that have been set to your preference.

▼ **Reset to factory default settings**

1. Select “Reset to Defaults” from the 2nd menu in the setting screen. Refer to “Setting screen” 3-52.

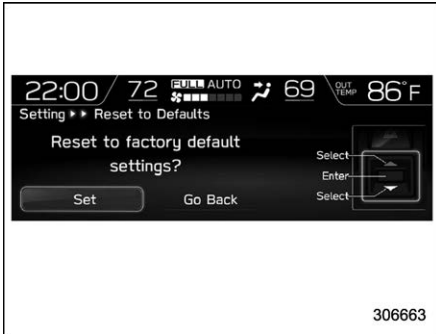

2. Select “Set” to exit settings. Select “Go Back” to return to the previous screen without resetting.

▼ **Lifetime fuel consumption resetting**

1. Select “Lifetime Fuel Cons Reset” from the 2nd menu in the setting screen. Refer to “Setting screen” 3-52.

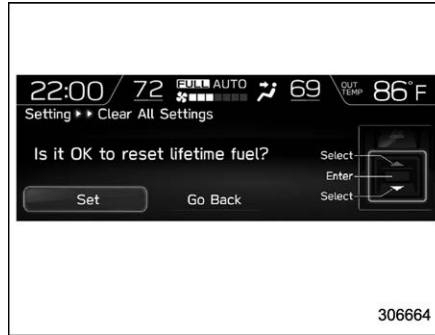

2. Select “Set” to exit settings. Select “Go Back” to return to the previous screen without resetting.

■ **How to get the source code using the open source**

Free/Open Source Software Information

This product contains Free/Open Source Software (FOSS).

The license information and/or the source code of such FOSS can be found at the following URL.

<http://www.globaldenso.com/en/open-source/ivi/subaru/>

## Clock

1. Turn the ignition switch to "ON".

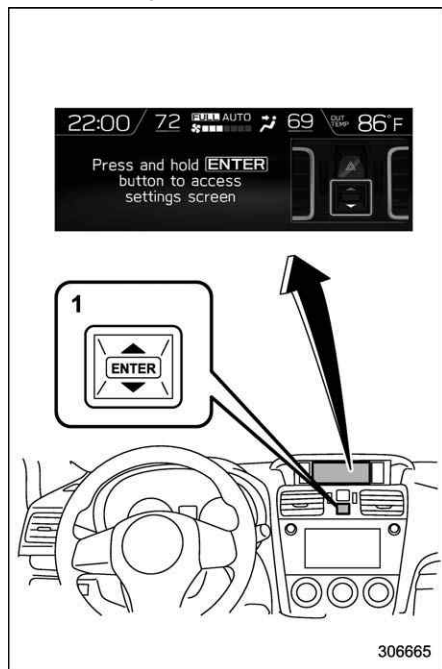

1) Control switch

2. While displaying the guidance screen, push and hold the control switch on the

instrument panel. The screen goes to the settings menu.

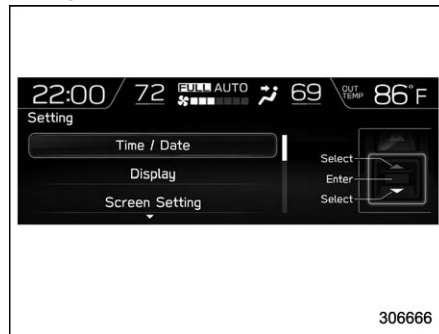

306666

3. Select "Time/Date" and push the control switch.

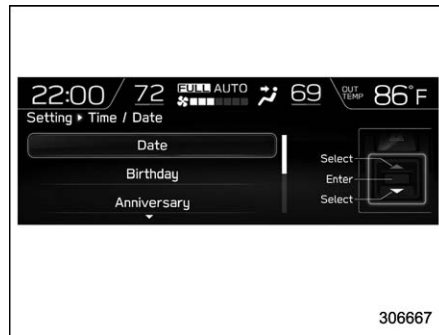

306667

4. Select "Date" and push the control switch.

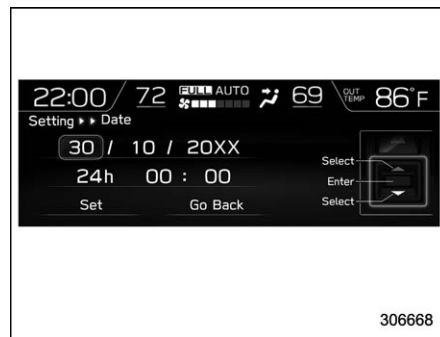

306668

5. Use the control switch to scroll through the items you can set.

(1) Use the control switch to choose the item you would like to change.

(2) Push the control switch to adjust the items.

6. Select "Set" and push the control switch to complete the clock setting.

Select "Go Back" to return to the previous screen without saving settings.

### NOTE

The Birthday/Anniversary and maintenance reminder system function are based on the time and date on the multi-function display (color LCD).



## Light control switch

### CAUTION

- Use of any lights for a long period of time while the engine is not running can cause the battery to discharge.
- Before leaving the vehicle, make sure that the lights are turned off. If the vehicle is left unattended for a long time with the lights illuminated, the battery may be discharged.

### Models with “keyless access with push-button start system”:

The light control switch operates when the push-button ignition switch is in the “ACC” or “ON” position.

Regardless of the position of the light control switch, the illuminated lights are turned off when the push-button ignition switch is turned off.

### Models without “keyless access with push-button start system”:

The light control switch operates when the key is inserted in the ignition switch.

Regardless of the position of the light control switch, the illuminated lights are

turned off when the key is removed from the ignition switch.

### NOTE

The light control switch can be operated (except auto on/off headlights), even under the following conditions.

- The push-button ignition switch is turned off (models with “keyless access with push-button start system”).
- The key is not inserted into the ignition switch (models without “keyless access with push-button start system”).

When opening the driver’s door with the headlights illuminated under such conditions, the chirp sound will inform the driver that the lights are illuminated.

## Headlights

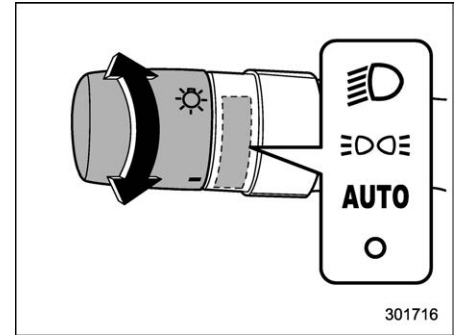

To turn on the headlights, turn the knob on the end of the turn signal lever.

### “D” position

Headlights, parking lights, front side marker lights, rear side marker lights, tail lights and license plate lights are on.

### “P” position

Parking lights, front side marker lights, rear side marker lights, tail lights and license plate lights are on.

### “Auto” position: auto on/off headlights (if equipped)

When the ignition switch is in the “ON” position, headlights, parking lights, front side marker lights, rear side marker lights, tail lights and license plate lights are

automatically on or off depending on the level of the ambient light.

### “O” position

The headlights are all off.

### NOTE

● **The sensitivity of the auto on/off headlights can be changed by a SUBARU dealer. Consult your SUBARU dealer for details. Also, you can change the settings using the multi-function display (color LCD). For details, refer to “Auto light sensor setting” 3-62.**

● **If the light control switch is in the “AUTO” position and the headlights do not turn on when it becomes dark outside, turn the light switch to the “D” position. If this happens, have your vehicle inspected by your SUBARU dealer as soon as possible.**

### ▼ Auto-on/off wiper-linked headlights (models with auto on/off headlights)

While the light control switch is in the “AUTO” position, the headlights will automatically turn on when the windshield wipers operate several times. The headlights will automatically turn off when the wipers stop.

The ON/OFF setting of this function can be changed by a SUBARU dealer. Consult your SUBARU dealer for details.

### ▼ Welcome lighting function (if equipped)

The welcome lighting function turns on some exterior lights for smooth approaching to or exiting from the vehicle at night or in dark places.

The function is activated while all of the following conditions are met.

- The light control switch is in the “AUTO” position.
- It is dark enough to turn on the auto on/off headlights.

### When approaching:

While the welcome lighting function is activated, some exterior lights will automatically illuminate when unlocking the doors by using the remote keyless entry system.

The exterior lights will remain illuminated for 30 seconds<sup>\*1</sup> and then turn off. However, if any of the following operations are performed, the exterior lights will turn off.

- Locking the doors using the keyless access function (if equipped) or the remote keyless entry system
- Turning the light control switch to a

position other than “AUTO”

- Turning the ignition switch to the “ON” position

### When exiting:

While the welcome lighting function is activated, some exterior lights will remain illuminated even when either of the following operations is performed.

- Turning the push-button ignition switch to the “OFF” status (models with “keyless access with push-button start system”)
- Pulling out the key from the ignition switch (models without “keyless access with push-button start system”)

The exterior lights will turn off under any of the following conditions.

- 3 minutes have passed since the exterior lights were illuminated by the welcome lighting function.
- 30 seconds have passed since the door was opened and closed.\*1
- The light control switch is turned to a position other than “AUTO”.
- The locking procedures using the keyless access function (if equipped) or the remote keyless entry system is performed twice. When performing the unlocking procedure after performing the locking procedure, perform the locking procedure twice again.

\*1: The setting for the period of time in which the exterior lights remain on by the welcome lighting function can be changed by a SUBARU dealer. Contact your SUBARU dealer for details. Also, you can change the setting using the multi-function display (color LCD). For details, refer to "Welcome lighting setting" 3-62.

▼ **Sensor for the auto on/off headlights (if equipped)**

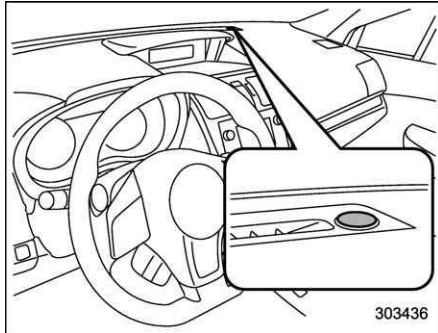

The sensor is on the instrument panel as shown in the illustration.

**CAUTION**

If any object is placed on or near the sensor, the sensor may not detect the level of the ambient light correctly and the auto on/off headlights

may not operate properly.

■ **High/low beam change (dimmer)**

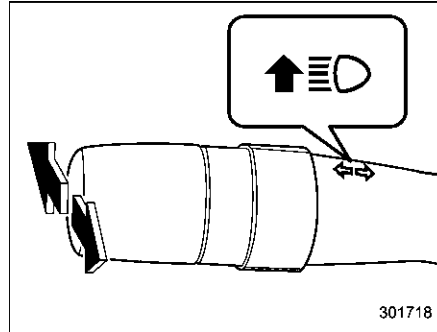

To change from low beam to high beam, push the turn signal lever forward. When the headlights are on high beam, the high beam indicator light "≡●" on the combination meter is also on.

To switch back to low beam, pull the lever back to the center position.

▼ **High beam assist function (models with the EyeSight system)**

**NOTE**

● The high beam assist function utilizes the stereo camera installed at the position of the front map lights.

● For details on how to handle the stereo camera, refer to the Owner's Manual supplement for the EyeSight system.

The high beam assist function automatically changes the headlight from high beam to low beam (or vice versa).

When all of the following conditions are met, the headlight will change to high beam.

- The vehicle speed increases to or above 20 mph (32 km/h).
- There is no preceding or oncoming vehicle.
- The forward area of the vehicle is dark.
- The road does not have a sharp curve.

When any of the following conditions is met, the headlight will change to low beam.

- The vehicle speed decreases to or below 10 mph (16 km/h).
- The forward area of the vehicle is bright.
- There is a preceding or oncoming vehicle.
- The EyeSight system is malfunctioning or is temporarily stopped.

## NOTE

- Do not overestimate the capacity of the high beam assist function. The driver always has the responsibility to understand the surrounding situation, to drive safely, and to change the headlight mode manually if necessary.
- The factory setting (default setting) for this function is set as “operational”. This setting can be changed to OFF (non-operation) at SUBARU dealers. For more details, contact a SUBARU dealer.

### ▽ How to use the high beam assist function

The high beam assist function will be activated when all the following conditions are met.

- The light control switch is in the “AUTO” position and the low beam headlights are on automatically.
- The turn signal lever is pushed forward.

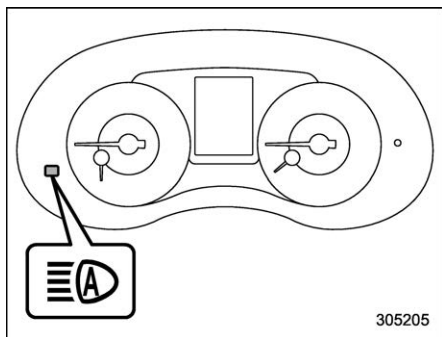

High beam assist indicator

When the high beam assist function is activated, the high beam assist indicator on the combination meter will illuminate.

## NOTE

If the high beam assist function is malfunctioning or is temporarily stopped, the headlight will be fixed at low beam. For details, refer to the Owner's Manual supplement for the EyeSight system.

### ▽ How to temporarily lower the sensitivity of the high beam assist function

You can lower the sensitivity of the high beam assist function by performing the following operations.

1. Before turning the ignition switch to the “ON” position, set the light control switch to the “AUTO” position and push the signal lever forward (high beam position).
2. Turn the ignition switch to the “ON” position and within approximately 15 seconds, press the “” (following distance setting) switch more than 10 times consecutively.

When the sensitivity of the high beam assist function is lowered, the high beam assist indicator light “” on the combination meter will flash.

## NOTE

- You cannot lower the sensitivity of the high beam assist function in the following conditions.
  - The cruise control or Adaptive Cruise Control indicator is illuminated.
  - The EyeSight warning indicator (yellow) is illuminated.
- The sensitivity of the high beam assist function returns to normal level the next time the ignition switch is turned to the “LOCK”/“OFF” position and the engine is restarted.

### ▽ How to change the headlight mode manually

#### Change to the low beam:

Return the turn signal lever to the center position to turn off the high beam assist function. Then the high beam assist indicator light will turn off.

#### Change to the high beam:

Turn the light control switch to the “

At this time, the high beam assist function will turn off, the high beam assist indicator light will turn off and the high beam indicator light will turn on.

### NOTE

**After manually selecting the high beam mode:**

- If you want to turn on the high beam assist function, return the light control switch to the “AUTO” position.
- Turn the light control switch to the “

### ▽ Tips for the high beam assist function

- The high beam assist function recognizes the condition surrounding the vehicle based on the brightness of illumination ahead of your vehicle, etc. Therefore, the headlight mode may switch in some situations that do not match to the driver’s sense.
  - A bicycle or cargo cycle may not be detected.
  - Under the following situations, the high beam assist function may not work properly. As a result, the glare of the high beam may disturb the oncoming vehicle or vehicle ahead. Also, the low beam mode may continue although there are no oncoming vehicles and vehicles ahead. In such cases, change the headlight mode manually.
    - In bad weather (fog, snow, sand storm, heavy rain, etc.)
    - When the windshield glass is dirty, fogged, cracked or damaged
    - When the stereo camera is deformed or the stereo camera lenses are dirty
    - If there are lights similar to the headlights or the tail lights in the surrounding area
    - When an oncoming vehicle or ve-

hicle ahead is driven without its headlights and tail lights on

- If the headlights of an oncoming vehicle or the tail lights of a vehicle ahead are dirty or discolored, or if the light beams are not aimed correctly
- When a rapid change of brightness continues while driving
- When driving on a road with many ups and downs, uneven surfaces or curves
- When there are some objects that reflect light strongly, such as a road sign or a mirror in vehicle ahead
- When the rear part of the vehicle ahead, such as a container, reflects light strongly
- When the headlights of your vehicle are damaged or dirty
- When your vehicle is tilted, such as in case the vehicle has a flat tire or is being towed
- Immediately after the engine has started
- In the following conditions, the headlight mode will not be automatically changed from the high beam to the low beam.
  - When your vehicle passes an oncoming vehicle suddenly in a blind curve
  - When another vehicle passes in front of your vehicle

- When an oncoming vehicle or vehicle ahead comes in and out of view because of continuous curves, median strips, roadside trees, etc.
- If the stereo camera detects the light of the front fog lights of an oncoming vehicle, the headlight mode may change from the high beam to the low beam automatically.
- The headlight mode may change from the high beam to the low beam, or the low beam mode may continue, when affected by a street light, traffic signal, illumination of an advertisement board, or a reflective object such as a road sign and signboard.
- The timing of the change of headlight mode may differ due to the following factors.
  - The vehicle condition (e.g., the number of passengers or the weight of loaded cargo)
  - Surrounding situation (e.g., the movement and direction of an oncoming vehicle or vehicle ahead)
  - Detection limitations of the camera angle

### ■ Headlight flasher

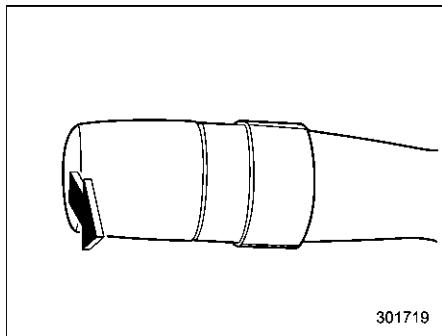

301719

#### ⚠ CAUTION

**Do not hold the lever in the flashing position for more than just a few seconds.**

To flash the headlights, pull the lever toward you and then release it. The high beam will stay on for as long as you hold the lever. The headlight flasher works even though the lighting switch is in the “O” (off) position.

When the headlights are on high beam, the high beam indicator light “” on the combination meter is also on.

### ■ Daytime running light system

#### ⚠ WARNING

**When the daytime running lights are illuminated, the tail lights do not illuminate. When it becomes dark outside, turn the light switch to the “” position to illuminate the headlights and tail lights. This will improve visibility and allow other drivers to see your vehicle more easily.**

The daytime running lights will automatically illuminate when the following conditions are fulfilled.

- The engine is running.
- The parking brake is fully released.
- The light control switch is in the “AUTO” (if equipped), “” or off position.
- For CVT models, the select lever is in a position other than the “P” position.

#### NOTE

**When the light switch is in the “” position, the instrument panel illumination, front side marker lights, tail lights and license plate lights are also illuminated.**

## Steering Responsive Headlight (SRH) (if equipped)

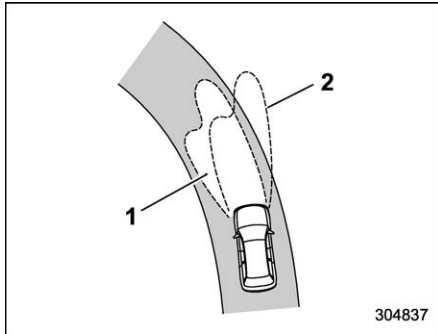

- 1) The target area of illumination when SRH is activated
- 2) The target area of illumination when SRH is not activated

SRH is a function that automatically moves the headlight beam to the left or right in accordance with the steering angle and vehicle speed. This function helps to improve the visibility at night by illuminating the road ahead at corners and intersections.

### NOTE

**SRH only activates when the vehicle is traveling forward at the speed of approximately 5 mph (8 km/h) and over.**

### ■ To turn on/off the SRH

Operate the combination meter display (color LCD) to turn on/off the SRH. For details, refer to "SRH" 3-43.

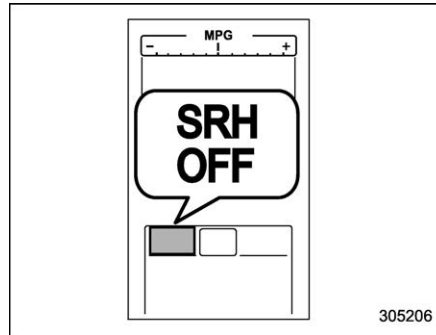

### SRH OFF indicator

The SRH OFF indicator on the combination meter turns off when SRH is turned on. The SRH OFF indicator on the combination meter illuminates when SRH is turned off.

If SRH is malfunctioning, the SRH OFF indicator on the combination meter flashes when the ignition switch is in the "ON" position. It indicates that SRH has been deactivated. Contact a SUBARU dealer for an inspection.

### NOTE

**When you turn the ignition switch to the "ON" position, the SRH OFF indicator will illuminate and turn off after several seconds.**

## Turn signal lever

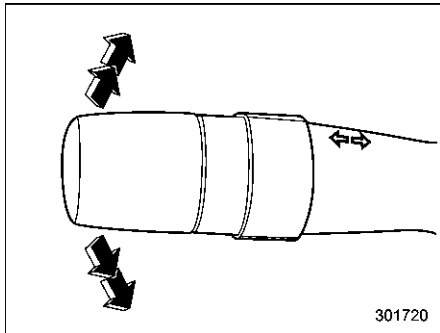

To activate the right turn signal, push the turn signal lever up. To activate the left turn signal, push the turn signal lever down. When the turn is finished, the lever will return automatically. If the lever does not return after cornering, return the lever to the neutral position by hand.

To signal a lane change, push the turn signal lever up or down slightly and hold it during the lane change. The turn signal indicator lights will flash in the direction of the turn or lane change. The lever will return automatically to the neutral position when you release it.

## ■ One-touch lane changer

To flash the turn signal and turn signal indicator light three times, push the turn signal lever up or down slightly and immediately release it.

The operational/non-operational setting of the one-touch lane changer's can be changed by a SUBARU dealer. Contact the nearest SUBARU dealer for details.

## Illumination brightness control

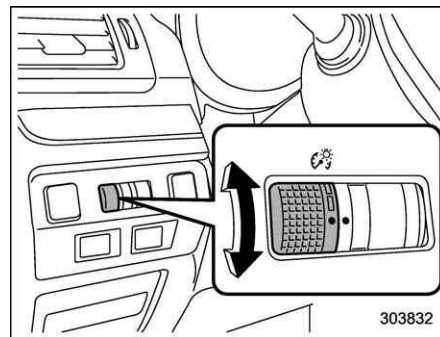

The instrument panel and the ambient lighting illuminate under the following conditions.

- The light switch is in the “ $\text{D}$ ” or “ $\text{D}$ ” position when the ambient light is dark.
- The light control switch is in the “AUTO” position and the headlights illuminate automatically.

You can adjust the illumination brightness for better visibility.

To brighten, turn the control dial upward.  
To darken, turn the control dial downward.

The multi-function display (color LCD) automatically adjusts its brightness to-



gether with the brightness level of the instrument panel. To adjust the display's contrast, refer to "Contrast setting" 3-56.

## NOTE

The brightness setting is not canceled even when the ignition switch is turned to the "LOCK"/"OFF" position.

## Automatic dimming function

If you turn on the parking lights, the illumination brightness of the combination meter, the climate control panel or other functions will automatically darken.

## NOTE

When you turn the control dial fully upward, the illumination brightness becomes the maximum level and the automatic dimming function will not work at all.

## Auto dimmer cancel function

If you turn on the parking lights with the ambient light bright, the illumination brightness of such items will not darken.

The operational/non-operational setting and sensitivity of the auto dimmer cancel function can be changed by your SUBARU dealer. Contact your SUBARU dealer for details.

## Headlight beam leveler (models with LED headlights)

### Automatic headlight beam leveler

The LED headlights generate more light than conventional halogen headlights.

Therefore, a driver of an oncoming vehicle may experience too much glare if your headlight beam height adjustment is high when the vehicle is carrying a heavy load.

The automatic headlight beam leveler adjusts the headlight beam height automatically and optimally according to the load being carried by the vehicle.

## Fog light switch (if equipped)

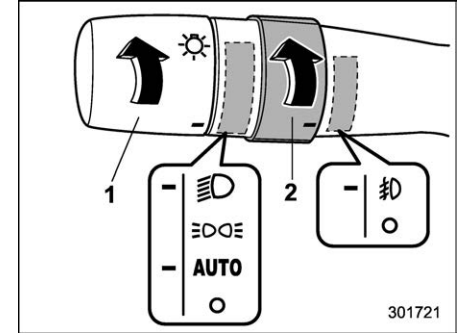

- 1) Headlight switch
- 2) Fog light switch

The front fog lights will turn on when the fog light switch is placed in the "☁" position while the headlights are on (e.g., the headlight switch is in the "☁" position).

To turn off the front fog lights, turn the switch back down to the "○" position.

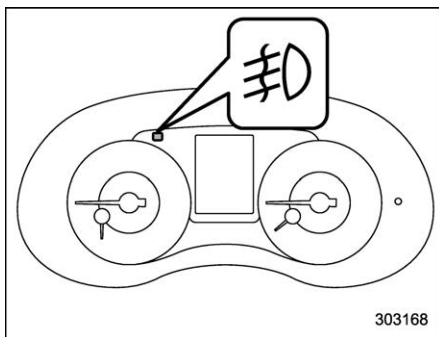

Front fog light indicator light

The indicator light on the combination meter will illuminate when the front fog lights are illuminated.

## Wiper and washer

### WARNING

In freezing weather, do not use the windshield washer until the windshield is sufficiently warmed by the defroster.

Otherwise the washer fluid can freeze on the windshield, blocking your view.

### CAUTION

- Do not operate the washer continuously for more than 10 seconds, or when the washer fluid tank is empty. This may cause overheating of the washer motor. Check the washer fluid level frequently, such as at fuel stops.
- Do not operate the wipers when the windshield is dry. This may scratch the glass, damage the blade rubbers and might cause the wiper motor to fail. Before operating the wiper on a dry windshield, always use the windshield washer.

- In freezing weather, be sure that the blade rubbers are not frozen to the windshield before switching on the wipers. Attempting to operate the wiper with the blade rubbers frozen to the window glass could cause not only the blade rubbers to be damaged but also might cause the wiper motor to fail. If the blade rubbers are frozen to the window glass, be sure to operate the defroster or the windshield wiper deicer (if equipped) before turning on the wiper.
- If the wipers stop during operation because of ice or some other obstruction on the window, this might cause the wiper motor to fail even if the wiper switch is turned off. If this occurs, promptly stop the vehicle in a safe place, turn the ignition switch to the "LOCK"/"OFF" position and clean the window glass to allow proper wiper operation.
- Use clean water if windshield washer fluid is unavailable. In areas where water freezes in winter, use SUBARU Windshield Washer Fluid or the equivalent. Refer to "Windshield washer

fluid" 11-38.

Also, when driving the vehicle when there are freezing temperatures, use non-freezing type wiper blades.

- Do not clean the wiper blades with gasoline or a solvent, such as paint thinner or benzine. This will cause deterioration of the wiper blades.

## NOTE

- The windshield wiper motor is protected against overloads by a circuit breaker. If the motor operates continuously under an unusually heavy load, the circuit breaker may trip to stop the motor temporarily. If this happens, park your vehicle in a safe place, turn off the wiper switch, and wait for approximately 10 minutes. The circuit breaker will reset itself, and the wipers will again operate normally.
- Clean your blade rubbers and window glass periodically with a washer solution to prevent streaking, and to remove accumulations of road salt or road film. Operate the windshield washer for at least 1 second so that washer solution will be sprinkled all over the windshield.

- Grease, wax, insects or other material on the windshield or the blade rubbers results in jerky wiper operation and streaking on the glass. If you cannot remove those streaks after operating the washer or if the wiper operation is jerky, clean the outer surface of the windshield and the blade rubbers using a sponge or soft cloth with a neutral detergent or mild-abrasive cleaner. After cleaning, rinse the window glass and blade rubbers with clean water. The glass is clean if no beads form on the glass when you rinse with water.
- If you cannot eliminate the streaking even after following this procedure, replace the wiper blades (or blade rubbers) with new ones. For replacement instructions, refer to "Replacement of wiper blades" 11-39.

## Windshield wiper and washer switches

The wiper operates only when the ignition switch is in the "ON" position.

### Windshield wipers

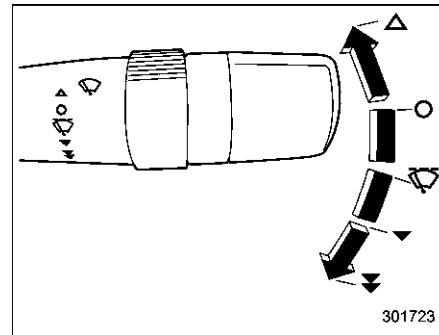

- △ : Mist (for a single wipe)
- : Off
- ☒ : Intermittent
- ▼ : Low speed
- ⚡ : High speed

To turn the wipers on, push the wiper control lever down.

To turn the wipers off, return the lever to the "○" position.

For a single wipe of the wipers, push the lever up. The wipers operate until you release the lever.

▼ **Wiper intermittent time control**

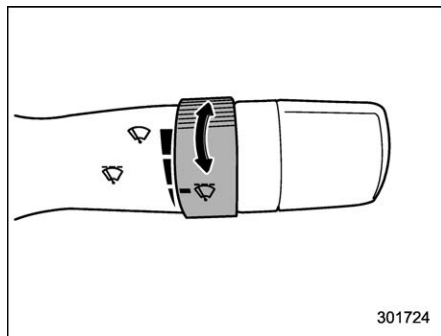

When the wiper switch is in the “” position, turn the dial to adjust the operating interval of the wiper. You can adjust the operating interval in several steps.

▼ **Windshield washer**

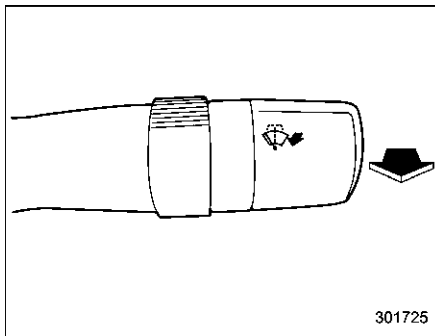

To wash the windshield, pull the wiper control lever toward you. The washer fluid sprays until you release the lever. The wipers operate while you pull the lever.

**NOTE**

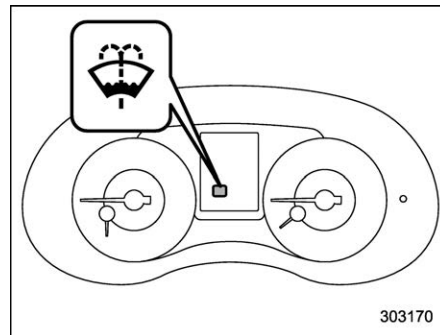

**The windshield washer fluid warning indicator appears when the washer fluid level in the tank has dropped to the lower limit. If the warning indicator appears, refill the tank with fluid. For the refilling procedure, refer to “Windshield washer fluid”  11-38.**

## Mirrors

Always check that the inside and outside mirrors are properly adjusted before you start driving.

### ■ Inside mirror

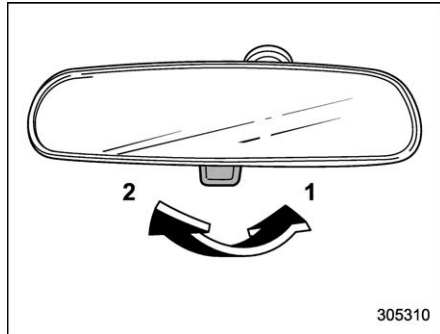

- 1) Normal position
- 2) Anti-glare position

Push the tab on the mirror for normal use. To reduce glare from the headlights of the vehicle behind you, pull the tab to the anti-glare position.

### ■ Auto-dimming mirror/compass (if equipped)

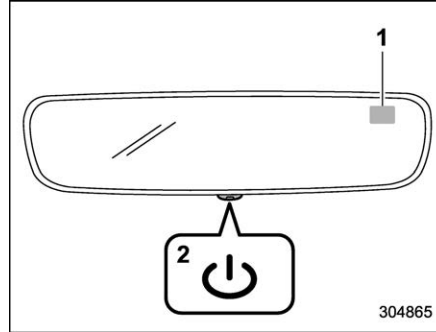

- 1) Display
- 2) Switch

During nighttime driving, the auto-dimming feature senses distracting glare from vehicle headlights behind you and automatically dims to eliminate the glare and preserve your vision.

### ▼ To Operate the Auto-Dimming Feature

Press the “” switch to turn the auto-dimming feature on/off. The auto-dimming feature is enabled when the switch’s green LED indicator is on. The auto-dimming feature will default to on with each ignition cycle.

### ▼ To Operate the Compass Feature

1. To turn the compass feature on/off, press and hold the “” switch for more than 3 seconds or until the display turns on/off. The compass feature will default to on with each ignition cycle.
2. If the display reads “C”, slowly drive the vehicle in circles until compass is calibrated.

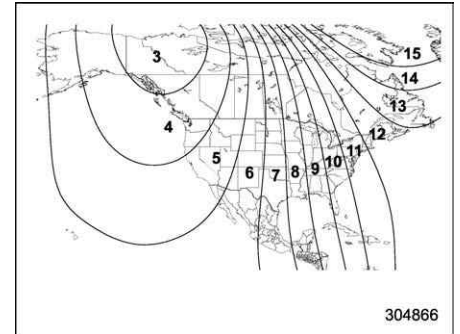

Compass calibration zones

3. To adjust for compass zone variance:
  - (1) Find your current location and zone number on the map.
  - (2) Press and hold the “⏻” switch for more than 6 seconds or until a zone number appears in the display.
  - (3) Once the zone number appears in the display, toggle the “⏻” switch again until your current location zone number appears. After you stop pressing the switch, your new zone number will be saved. Within a few seconds, the display will show a compass direction.
4. If the vehicle’s magnetics have changed or if the compass appears inaccurate, recalibrate the compass. Press and hold the “⏻” switch for more than 9 seconds or until a “C” appears in the display. Once a “C” appears in the display, slowly drive the vehicle in circles until compass is calibrated.

### ■ Auto-dimming mirror/compass with HomeLink® (if equipped)

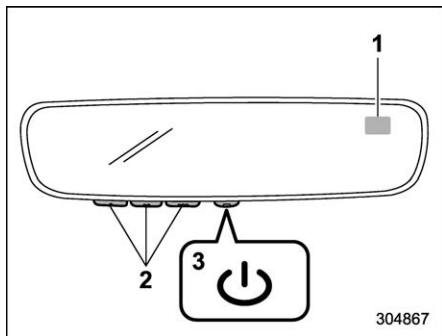

- 1) Display
- 2) HomeLink Buttons
- 3) Switch

During nighttime driving, the auto-dimming feature senses distracting glare from vehicle headlights behind you and automatically dims to eliminate the glare and preserve your vision.

### ▼ To Operate the Auto-Dimming Feature

Press the “⏻” switch to turn the auto-dimming feature on/off. The auto-dimming feature is enabled when the switch’s green LED indicator is on. The auto-dimming feature will default to on with each ignition cycle.

### ▼ To Operate the Compass Feature

1. To turn the compass feature on/off, press and hold the “⏻” switch for more than 3 seconds or until the display turns on/off. The compass feature will default to on with each ignition cycle.
2. If the display reads “C”, slowly drive the vehicle in circles until compass is calibrated.

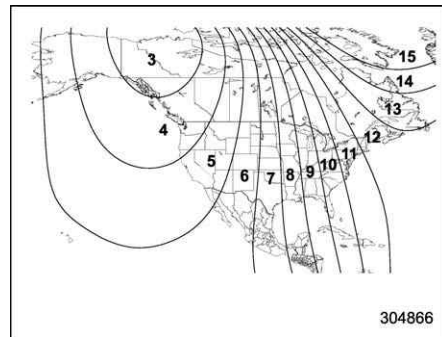

Compass calibration zones

3. To adjust for compass zone variance:
  - (1) Find your current location and zone number on the map.
  - (2) Press and hold the “U” switch for more than 6 seconds or until a zone number appears in the display.
  - (3) Once the zone number appears in the display, toggle the “U” switch again until your current location zone number appears. After you stop pressing the switch, your new zone number will be saved. Within a few seconds, the display will show a compass direction.
4. If the vehicle’s magnetics have changed or if the compass appears inaccurate, recalibrate the compass. Press and hold the “U” switch for more than 9 seconds or until a “C” appears in the display. Once a “C” appears in the display, slowly drive the vehicle in circles until compass is calibrated.

#### ▼ HomeLink® Wireless Control System

The HomeLink® Wireless Control System provides a convenient way to replace up to three hand-held radio-frequency remotes used to activate devices such as gate operators, garage door openers, entry door locks, security systems, even home lighting. The below steps are generic programming instructions; for Genie and Sommer garage door openers please go directly to the HomeLink website. Additional information and programming videos can be found at [www.HomeLink.com](http://www.HomeLink.com) and [www.youtube.com/HomeLinkGentex](http://www.youtube.com/HomeLinkGentex).

#### CAUTION

- **Before programming HomeLink to a garage door opener or gate operator, make sure that people and objects are out of the way of the device to prevent potential harm or damage.**
- **When programming a garage door opener, it is advised to park outside of the garage.**
- **Do not use HomeLink with any garage door opener that lacks safety stop and reverse features as required by U.S. federal safety**

standards (this includes any garage door opener model manufactured before April 1, 1982). A garage door that cannot detect an object signaling the door to stop and reverse does not meet current U.S. federal safety standards.

- **It is also recommended that a new battery be placed in the hand-held remote (garage door opener remote) of the device for quicker and more accurate training.**
- **Some vehicles may require the ignition switch to be turned to the “ON” or “ACC” position for programming and/or operation of HomeLink.**
- **Keep the hand-held remote (garage door opener remote) of the device you are programming for use in other vehicles as well as for future HomeLink programming. It is also suggested that upon the sale of the vehicle, the programmed HomeLink buttons be erased for security purposes. Refer to “Erasing HomeLink Buttons” 3-82.**

▽ Programming a New HomeLink Button

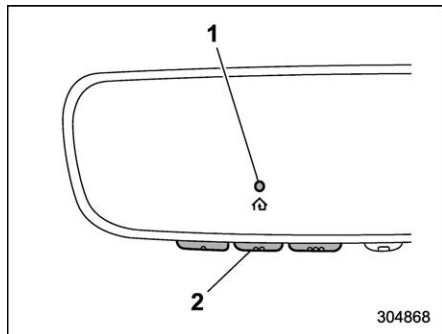

- 1) Indicator Light
- 2) HomeLink Buttons

1. Press and release the HomeLink button that you would like to program. The HomeLink indicator light will flash orange slowly (if not, refer to “Erasing HomeLink Buttons” 3-82).

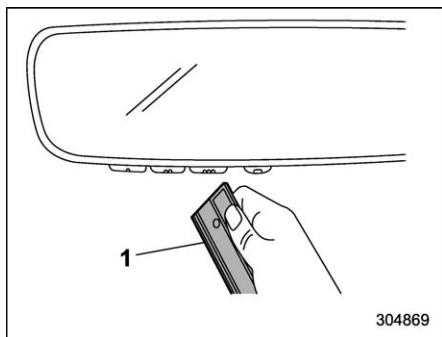

- 1) Garage door opener remote

2. Position the hand-held remote (garage door opener remote) 1 to 3 in (2 to 8 cm) away from the HomeLink button that you would like to program.

**NOTE**

Some hand-held remotes (garage door opener remotes) may actually train better at a distance of 6 to 12 in (15 to 30 cm). Keep this in mind if you have difficulty with the programming process.

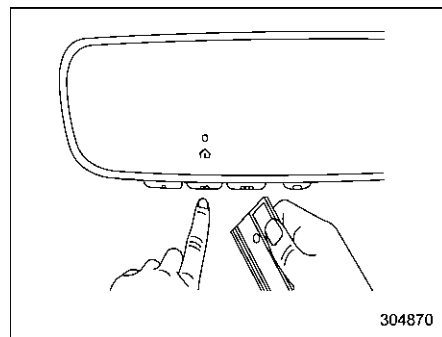

3. While the HomeLink indicator light is flashing orange, press and hold the hand-held remote button. Continue pressing the hand-held remote button until the HomeLink indicator light changes from orange to green. You may now release the hand-held remote button.

**NOTE**

Some devices may require you to replace this “Programming a New HomeLink Button” step 3 with procedures noted in the “Gate Operator / Canadian Programming” section. Refer to “Gate Operator/Canadian Programming” 3-82.



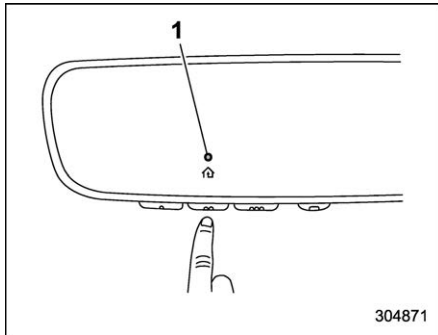

1) Indicator Light

4. Press the HomeLink button that you would like to program and observe the indicator light.

- If the indicator light remains constant green, your device should operate when the HomeLink button is pressed. At this point, if your device operates, programming is complete.
- If the indicator light rapidly flashes green, firmly press, hold for two seconds and release the HomeLink button up to three times to complete the programming process. At this point if your device operates, programming is complete. If the device does not operate, continue with the next step of the programming instructions.

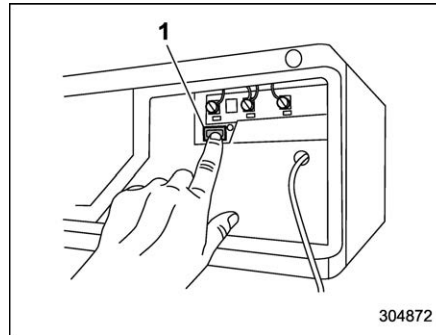

1) "Learn" button

5. At the garage door opener motor, (security gate motor, etc.) locate the "Learn", "Smart", or "Program" button. This can usually be found where the hanging antenna wire is attached to the motor-head unit (see the device's manual to identify this button). The name and color of the button may vary by manufacturer.

### NOTE

**A ladder and/or second person may simplify the following steps.**

6. Firmly press and release the "Learn", "Smart", or "Program" button. You now have 30 seconds in which to complete step 7.

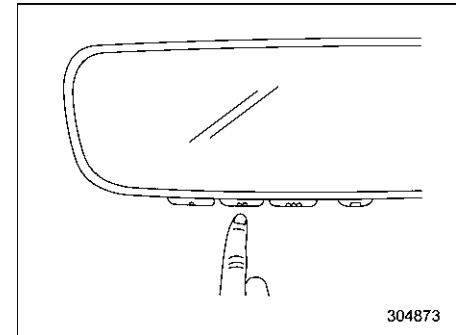

304873

7. Return to the vehicle and firmly press, hold for two seconds and release the HomeLink button up to three times. At this point programming is complete and your device should operate when the HomeLink button is pressed and released.

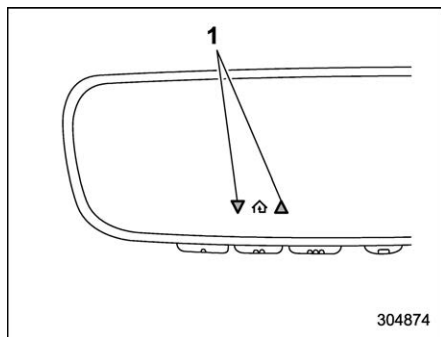

1) Status Indicators

8. If status indicator arrows appear next to the indicator light, please refer to “Garage Door Two-Way Communication” 3-83.

In the event that there are still programming difficulties or questions, additional HomeLink information and programming videos can be found at [www.HomeLink.com](http://www.HomeLink.com) and [www.youtube.com/HomeLinkGentex](http://www.youtube.com/HomeLinkGentex). For Genie and Sommer garage door openers please go directly to the HomeLink website.

### ▽ Gate Operator/Canadian Programming

Canadian radio-frequency laws require transmitter remote signals to “time-out” (or quit) after several seconds of transmission, which may not be long enough for HomeLink to pick up the signal during programming. Similar to this Canadian law, some U.S. gate operators are designed to “time-out” in the same manner. The indicator LED on the hand-held remote will go off when the device times out, indicating that it has finished transmitting.

If you live in Canada or you are having difficulties programming a gate operator or garage door opener by using the programming procedures, replace “Programming a New HomeLink Button” step 3 with the following:

While the HomeLink indicator light is flashing orange, press and release (“cycle”) your device’s hand-held remote every two seconds until the HomeLink indicator light changes from orange to green. You may now release the hand-held remote button.

### NOTE

**If programming a garage door opener or gate operator, it is advised to unplug**

**the device during the “cycling” process to prevent possible overheating.**

Proceed with “Programming a New HomeLink Button” step 4 to complete.

### ▽ Using HomeLink

To operate, simply press and release the programmed HomeLink button. Activation will now occur for the trained device (i.e. garage door opener, gate operator, security system, entry door lock, home/office lighting, etc.). For convenience, the hand-held remote of the device may also be used at any time.

### ▽ Erasing HomeLink Buttons

To erase programming from the three buttons (individual buttons cannot be erased but can be “reprogrammed” as outlined below), follow the step noted:

Press and hold the two outer HomeLink buttons for at least 10 seconds. The LED indicator will change from continuously lit to rapidly flashing. Release both buttons. Do not hold for longer than 20 seconds. HomeLink is now ready to be programmed at any time beginning with “Programming a New HomeLink Button” - step 1.

### ▽ Reprogramming a Single HomeLink Button

To program a previously trained button, follow these steps:

1. Press and hold the desired HomeLink button. DO NOT release the button.
2. The indicator light will begin to slowly flash orange after 20 seconds. The HomeLink button can be released at this point. Proceed with "Programming a New HomeLink Button" - step 3.
3. If you do not complete the programming of a new device to the button, it will revert to the previously stored programming.

### ▽ Garage Door Two-Way Communication

HomeLink has the capability of communicating with your garage door opener. HomeLink can receive and display "closing" or "opening" status messages from compatible garage door opener systems. At any time, HomeLink can also recall and display the last recorded status communicated by the garage door opener to indicate your garage door being "closed" or "opened".

HomeLink has the capability of receiving this communication from the garage door opener at a range up to 820 feet (250 m). Range may be reduced by obstacles such as houses or trees. You may have to slow your vehicle speed to successfully receive the garage door opener communication.

### ▽ Programming Two-Way Communication

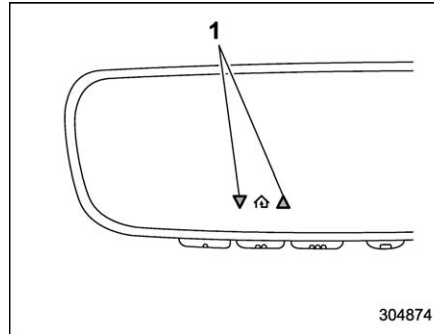

1) Status Indicators

Within five seconds after programming a new HomeLink button, both of HomeLink's garage door status indicators will flash rapidly green indicating that the garage door two-way communication has been enabled. If your garage door status indicators flashed, two-way communication programming is complete.

If the garage door status indicators do not flash, additional HomeLink information and programming videos can be found online at [www.HomeLink.com](http://www.HomeLink.com) and [www.youtube.com/HomeLinkGentex](http://www.youtube.com/HomeLinkGentex).

### ▽ Using Two-Way Communication

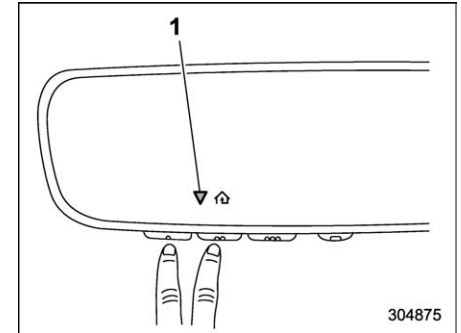

1) Status Indicators

Recall and display (at any time) the last recorded garage door status message communicated to HomeLink by simultaneously pressing HomeLink buttons 1 and 2 for two seconds. HomeLink will display the last recorded status for three seconds.

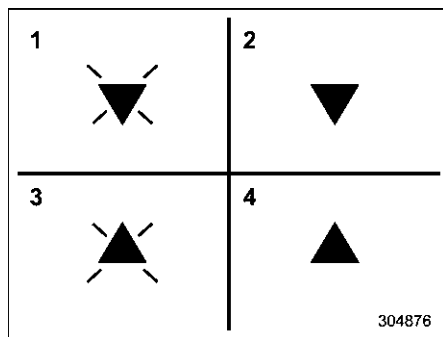

- 1) Garage Door Opener CLOSING (Blinking Orange)
- 2) Garage Door Opener CLOSED (Solid Green)
- 3) Garage Door Opener OPENING (Blinking Orange)
- 4) Garage Door Opener OPENED (Solid Green)

If two-way communication programming is successful, HomeLink will display the status of your garage door opener with arrow indicators.

▽ **Certification**

In the event that there are still programming difficulties or questions, additional HomeLink information and programming videos can be found at [www.HomeLink.com](http://www.HomeLink.com), [www.youtube.com/HomeLinkGentex](http://www.youtube.com/HomeLinkGentex), or by calling the toll-free HomeLink-hotline at 1-800-355-3515.

- **U.S.-spec. models**



**FCC WARNING**

**Changes or modifications not expressly approved by the party responsible for compliance could void the user's authority to operate the equipment.**

This device complies with FCC rules part 15 and Innovation, Science, and Economic Development Canada RSS-210. Operation is subject to the following two conditions: (1) This device may not cause harmful interference, and (2) This device must accept any interference that may be received including interference that may cause undesired operation. **WARNING:** The transmitter has been tested and complies with FCC and ISED rules.

Changes or modifications not expressly approved by the party responsible for compliance could void the user's authority to operate the device.

This equipment complies with FCC and ISED radiation exposure limits set forth for an uncontrolled environment. End Users must follow the specific operating instructions for satisfying RF exposure compliance. This transmitter must be at least 20 cm from the user and must not be co-located or operating in conjunction with any other antenna or transmitter.

### ● Canada-spec. models

This device complies with FCC rules part 15 and Innovation, Science, and Economic Development Canada RSS-210. Operation is subject to the following two conditions: (1) This device may not cause harmful interference, and (2) This device must accept any interference that may be received including interference that may cause undesired operation. **WARNING:** The transmitter has been tested and complies with FCC and ISDE rules.

Changes or modifications not expressly approved by the party responsible for compliance could void the user's authority to operate the device.

This equipment complies with FCC and ISDE radiation exposure limits set forth for an uncontrolled environment. End Users must follow the specific operating instructions for satisfying RF exposure compliance. This transmitter must be at least 20 cm from the user and must not be co-located or operating in conjunction with any other antenna or transmitter.

306210

Cet appareil est conforme aux règlements de la FCC, section 15, et au CNR-210 d'Innovation, Sciences et Développement économique Canada. Le fonctionnement est assujéti aux deux conditions suivantes : (1) cet appareil ne doit pas causer d'interférences nuisibles et (2) cet appareil doit accepter toute interférence reçue, y compris celle qui pourrait entraîner un dysfonctionnement. **MISE EN GARDE :** L'émetteur a subi des tests et est conforme aux règlements de la FCC et d'ISDE. Les changements ou modifications non approuvés explicitement par la partie responsable de la conformité pourraient rendre caduque l'autorisation de l'utilisateur de se servir du dispositif.

Cet appareil est conforme aux limites d'exposition aux radiations de la FCC et d'ISDE établies pour un environnement non contrôlé. Les utilisateurs finaux doivent respecter les instructions d'utilisation spécifiques pour satisfaire aux exigences de conformité aux expositions de RF. L'émetteur doit se trouver à 20 cm au minimum de l'utilisateur et ne doit pas être situé au même endroit que tout autre émetteur ou antenne ni fonctionner avec un autre émetteur ou antenne.

306211

HomeLink® and the HomeLink® house are registered trademarks of Gentex Corporation.



### WARNING

- **When programming the HomeLink® Wireless Control System, you may be operating a garage door opener or other device. Make sure that people and objects are out of the way of the garage door or other device to prevent potential harm or damage.**
- **Do not use the HomeLink® Wireless Control System with a garage door opener that lacks the safety stop and reverse feature as required by applicable safety standards. A garage door opener which cannot detect an object, signaling the door to stop and reverse, does not meet these safety standards. Using a garage door opener without these features increases risk of serious injury or death. For more information, consult the HomeLink® website at [www.homelink.com](http://www.homelink.com) or call 1-800-355-3515.**

## ■ Outside mirrors

### ▼ Convex mirror (passenger side)

#### WARNING

Objects look smaller in a convex mirror and farther away than when viewed in a flat mirror. Do not use the convex mirror to judge the distance of vehicles behind you when changing lanes. Use the inside mirror (or glance backwards) to determine the actual size and distance of objects that you view in convex mirror.

#### CAUTION

Make sure to adjust the mirrors before driving.

### ▼ Remote control mirror switch

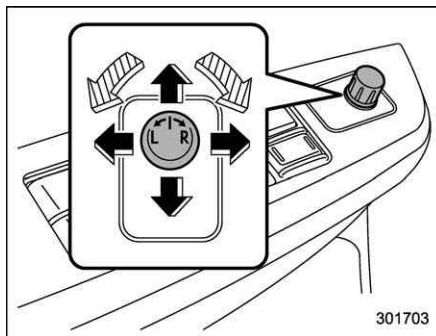

 Select side to adjust

 Direction control

The remote control mirrors operate only when the ignition switch is in the "ON" or "ACC" position.

1. Turn the control switch to the side that you want to adjust. "L" is for the left mirror, "R" is for the right mirror.
2. Move the control switch in the direction you want to move the mirror.
3. Return the control switch to the neutral position to prevent unintentional operation.

You can also adjust the mirrors manually.

## Defogger and deicer

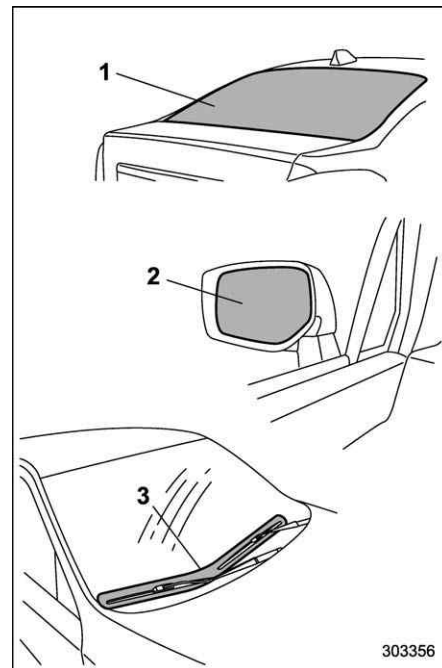

- 1) Rear window defogger
- 2) Outside mirror defogger
- 3) Windshield wiper deicer (if equipped)

The defogger and deicer system is acti-

vated only when the ignition switch is in the “ON” position.

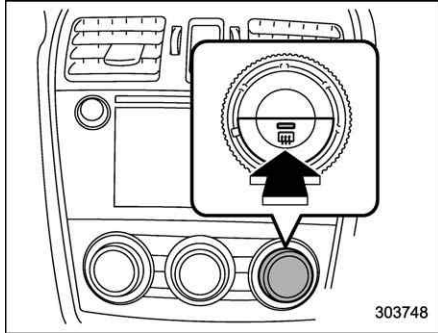

#### Control switch

To activate the defogger and deicer system, press the control switch that is located on the climate control panel. The rear window defogger, outside mirror defogger and windshield wiper deicer are activated simultaneously. The indicator light on the control switch illuminates while the defogger and deicer system is activated.

To turn them off, press the control switch again. They also turn off when the ignition switch is turned to the “ACC” or “LOCK”/“OFF” position.

The defogger and deicer system will automatically shut off after approximately 15 minutes. If the rear window and the

outside mirrors have been cleared and the windshield wiper blade rubbers have been deiced completely before that time, press the control switch to turn them off. If defrosting, defogging or deicing is not complete, you have to press the control switch to turn them on again.

It is possible for the defogger and deicer system to be set to continuous operation mode by a SUBARU dealer. Consult your SUBARU dealer for details. Also, you can change the setting using the multi-function display (color LCD). For details, refer to “Defogger setting” 3-61.

If the battery voltage drops below the permissible level, continuous operation of the defogger and deicer system is canceled and the system stops operating.

#### CAUTION

- To prevent the battery from being discharged, do not operate the defogger and deicer system continuously for any longer than necessary.
- Do not use sharp instruments or window cleaner containing abrasives to clean the inner surface of the rear window. They may damage the conductors printed on

the window.

#### NOTE

- Turn on the defogger and deicer system if the wipers are frozen to the windshield.
- If the windshield is covered with snow, remove the snow so that the windshield wiper deicer works effectively.
- While the defogger and deicer system is in the continuous operation mode:
  - If the vehicle speed remains at 9 mph (15 km/h) or lower for 15 minutes, the windshield wiper deicer system automatically stops operating. However, the rear window defogger system and outside mirror defogger system maintain continuous operation in this condition.
  - If the vehicle battery voltage drops below the permissible level, continuous operation of the defogger system and deicer system is canceled and the system stops operating.

## Tilt/telescopic steering wheel

### WARNING

- Do not adjust the steering wheel tilt/telescopic position while driving. This may cause loss of vehicle control and result in personal injury.
- If the lever cannot be raised to the fixed position, adjust the steering wheel again. It is dangerous to drive without locking the steering wheel. This may cause loss of vehicle control and result in personal injury.

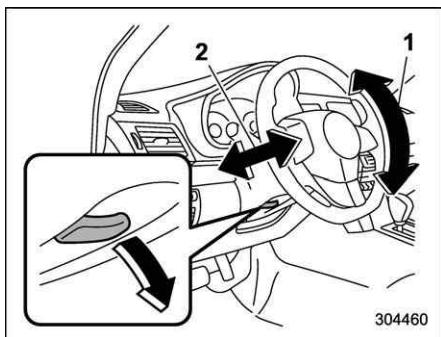

- 1) Tilt adjustment
- 2) Telescopic adjustment

1. Adjust the seat position. Refer to “Front seats” 1-2.
2. Pull the tilt/telescopic lock lever down.
3. Move the steering wheel to the desired level.
4. Pull the lever up to lock the steering wheel in place.
5. Make sure that the steering wheel is securely locked by moving it up and down, and forward and backward.

## Horn

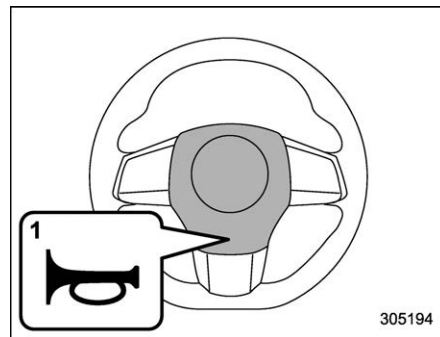

- 1) Horn mark

To sound the horn, push the horn pad.



Ventilator control .....	4-2
Center and side ventilators .....	4-2
Climate control panel .....	4-3
Type A .....	4-3
Type B .....	4-4
Automatic climate control operation.....	4-5
Sensors .....	4-6
Manual climate control operation.....	4-6
Airflow mode selection.....	4-6
Temperature control.....	4-8
Fan speed control.....	4-8
Air conditioner control.....	4-8
Air inlet selection.....	4-9
Defrosting.....	4-9

Operating tips for heater and air conditioner ....	4-10
Cleaning ventilation grille .....	4-10
Efficient cooling after parking in direct sunlight ....	4-10
Lubrication oil circulation in the refrigerant circuit.....	4-10
Checking air conditioning system before summer season.....	4-10
Cooling and dehumidifying in high humidity and low temperature weather conditions.....	4-10
Air conditioner compressor shut-off when engine is heavily loaded .....	4-10
Refrigerant for your climate control system .....	4-10
Air filtration system.....	4-11
Replacing the cabin air filter .....	4-11

## Ventilator control

### ■ Center and side ventilators

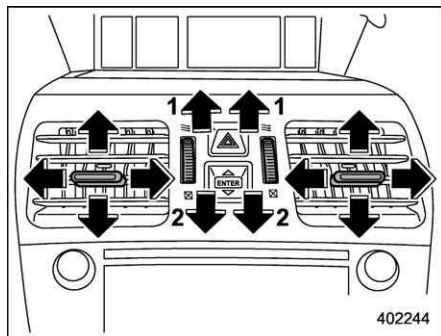

#### Center ventilators

- 1) Open
- 2) Close

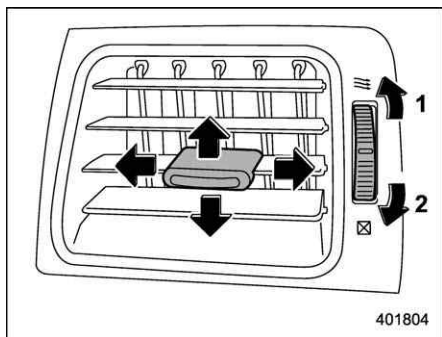

#### Side ventilators

- 1) Open
- 2) Close

To adjust the flow direction, move the tab.  
To open or close the ventilator, turn the thumb-wheel up or down.

## Climate control panel

### ■ Type A

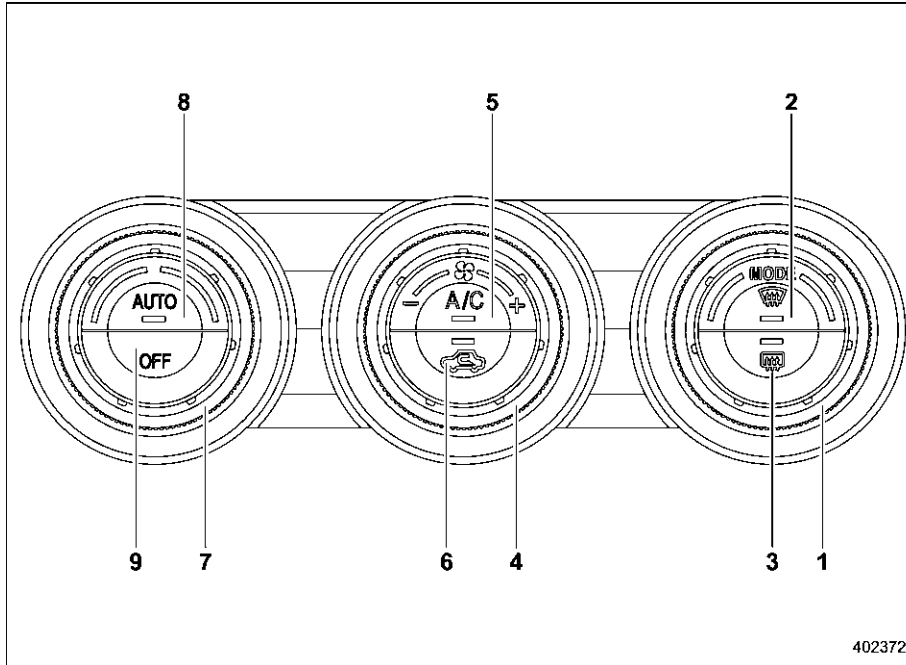

- 1) Airflow mode selection dial (Refer to "Airflow mode selection" ¶4-6.)
- 2) Defroster button (Refer to "Airflow mode selection" ¶4-6.)
- 3) Rear window defogger button (Refer to "Defogger and deicer" ¶3-86.)
- 4) Fan speed control dial (Refer to "Fan speed control" ¶4-8.)
- 5) Air conditioner button (Refer to "Air conditioner control" ¶4-8.)
- 6) Air inlet selection button (Refer to "Air inlet selection" ¶4-9.)
- 7) Temperature control dial (Refer to "Automatic climate control operation" ¶4-5 and/or "Temperature control" ¶4-8.)
- 8) AUTO button (Refer to "Automatic climate control operation" ¶4-5.)
- 9) OFF button (Refer to "Automatic climate control operation" ¶4-5.)

402372

■ Type B

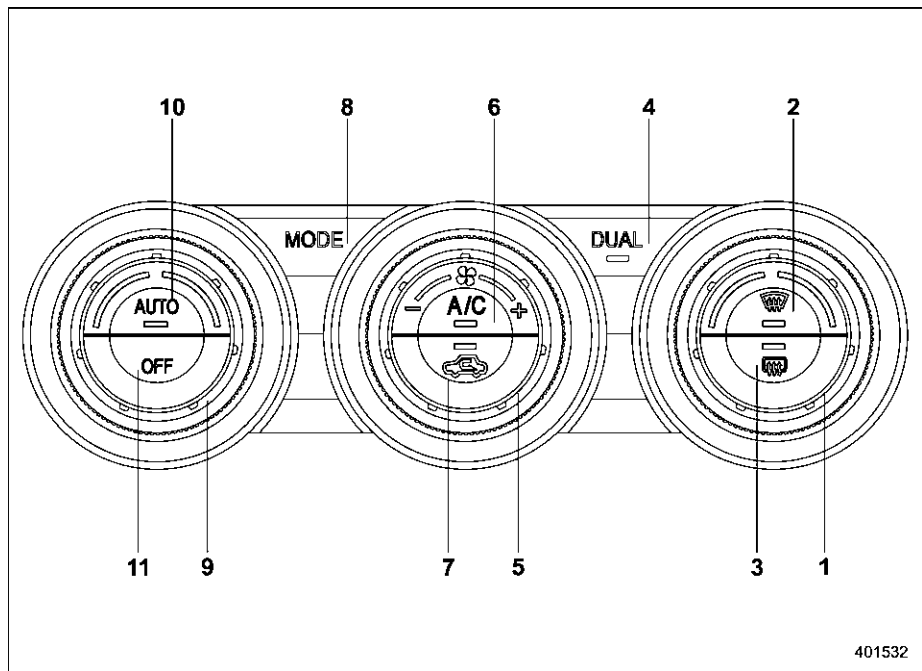

- 1) Temperature control dial (Refer to "Automatic climate control operation" 4-5 and/or "Temperature control" 4-8.)
- 2) Defroster button (Refer to "Airflow mode selection" 4-6.)
- 3) Rear window defogger button (Refer to "Defogger and deicer" 3-86.)
- 4) DUAL mode button (Refer to "DUAL" mode (type B)" 4-8.)
- 5) Fan speed control dial (Refer to "Fan speed control" 4-8.)
- 6) Air conditioner button (Refer to "Air conditioner control" 4-8.)
- 7) Air inlet selection button (Refer to "Air inlet selection" 4-9.)
- 8) Airflow mode selection button (Refer to "Airflow mode selection" 4-6.)
- 9) Temperature control dial (Refer to "Automatic climate control operation" 4-5 and/or "Temperature control" 4-8.)
- 10) AUTO button (Refer to "Automatic climate control operation" 4-5.)
- 11) OFF button (Refer to "Automatic climate control operation" 4-5.)

## Automatic climate control operation

When this mode is selected, the fan speed, airflow distribution, air-inlet control, and air conditioner compressor operation are automatically controlled. To activate this mode, perform the following.

### NOTE

- Operate the automatic climate control system when the engine is running.
- Even when cooling is not necessary, the air conditioner compressor will automatically turn on if the temperature is set much lower than the current outlet air temperature. Even in this case, the “A/C” indicator light on the control panel illuminates.
- The air conditioner may not operate in the following cases:
  - When the cabin temperature is low
  - When the ambient temperature decreases close to 32°F (0°C)

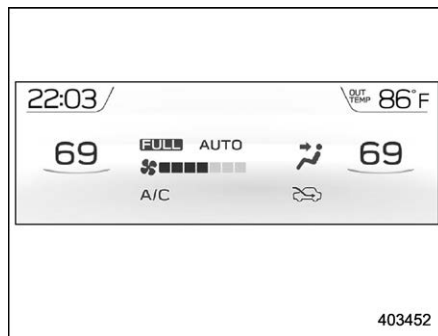

1. Depress the “AUTO” button. The indicator “FULL AUTO” on the display illuminates.
2. Set the preferred temperature using the temperature control dial.

### NOTE

- The controllable temperature range may vary depending on the regional specifications of the vehicle.
- During FULL AUTO mode operation, a small amount of air may flow from the foot outlets when ventilation mode is displayed.
- If you operate any of the buttons on the control panel other than the “OFF” button, rear window defogger button and temperature control dial(s) during FULL AUTO mode operation, the

“FULL” indicator on the control panel will turn off and the “AUTO” indicator will remain illuminated. You can then manually control the system as desired using the button you operated. To change the system back to the FULL AUTO mode, press the “AUTO” button.

- When the climate control system turns off, the air inlet is fixed to the outside air mode.

To turn off the climate control system, press the “OFF” button.

## ■ Sensors

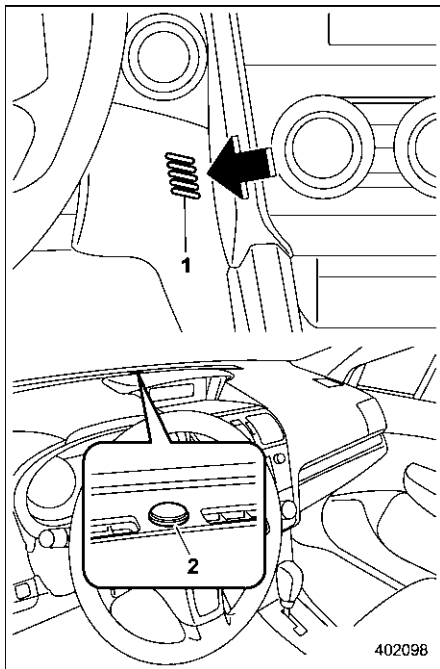

- 1) Interior air temperature sensor
- 2) Solar sensor

The automatic climate control system employs several sensors. The sensors are located as follows.

- Solar sensor: beside the windshield defroster grille
- Interior air temperature sensor: next to the steering column
- Outside temperature sensor: near the front bumper opening

These sensors are delicate. If they are not treated properly and become damaged, the system may not be able to control the interior temperature correctly. To avoid damaging the sensors, observe the following precautions.

- Do not subject the sensors to impact.
- Keep water away from the sensors.
- Do not cover the sensors.

## Manual climate control operation

### ■ Airflow mode selection

To select the airflow mode:

**Type A:** Turn the airflow mode selection dial.

**Type B:** Press the airflow mode selection button.

To select the defrost mode:

Press the defroster button.

Airflow modes are as follows.

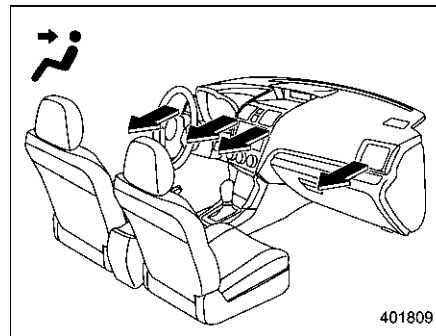

**(Ventilation):** Instrument panel outlets

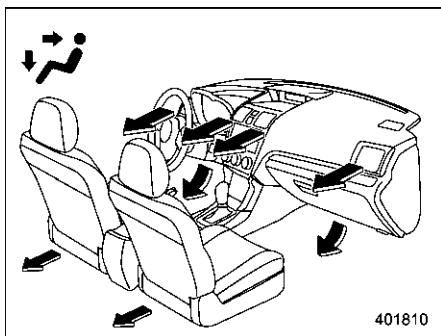

**(Bi-level):** Instrument panel outlets and foot outlets

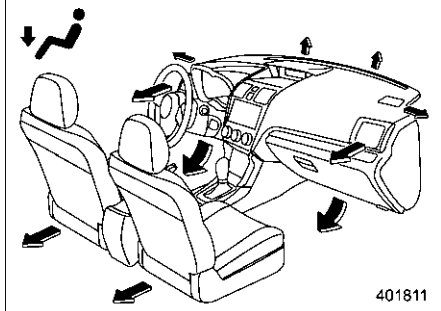

**(Heat):** Foot outlets, both side outlets of the instrument panel and some through windshield defroster outlets (A small amount of air flows to the windshield and

both side windows to prevent fogging.)

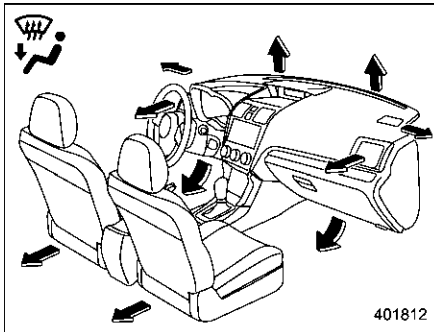

**(Heat-def):** Windshield defroster outlets, foot outlets and both side outlets of the instrument panel (Refer to "Defrosting" ¶4-9.)

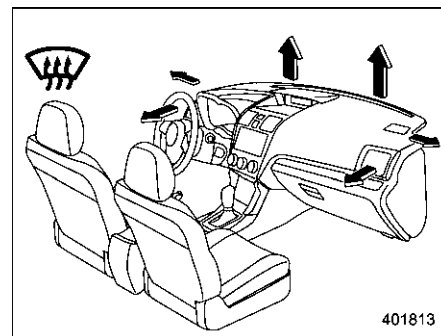

**(Defrost):** Windshield defroster outlets and both side outlets of the instrument panel (Refer to "Defrosting" ¶4-9.)

### NOTE

When the "☀️" or "❄️" mode is selected, the air conditioner compressor operates automatically regardless of the position of the air conditioner button to defrost the windshield more quickly. However, the indicator on the air conditioner button may not illuminate. At the same time, the air inlet selection is automatically set to the outside air mode. After defrosting the windshield by pressing the defroster button "☀️", pressing the button again returns the system to the setting that had been selected before the defroster

was activated.

## ■ Temperature control

Turn the temperature control dial to set the preferred interior temperature. With the dial set to your preferred temperature, the system automatically adjusts the temperature of air supplied from the outlets so that the preferred temperature is achieved and maintained.

If the dial is turned fully counterclockwise, the system provides maximum cooling performance. If the dial is turned fully clockwise, the system provides maximum heating performance.

### NOTE

**The controllable temperature range may vary depending on the regional specifications of the vehicle.**

### ▼ “DUAL” mode (type B)

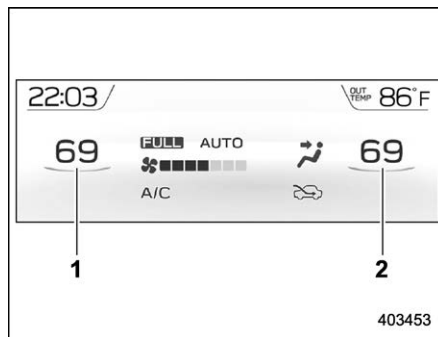

- 1) Driver's side temperature
- 2) Front passenger's side temperature

You can change the setting of the driver's side and front passenger's side temperature independently by selecting the “DUAL” mode.

Perform either of the following procedures to select the “DUAL” mode.

- Press the “DUAL” button.
- Turn the passenger's side temperature control dial.

Press the “DUAL” button to cancel the “DUAL” mode.

#### When the “DUAL” mode is selected:

Turn the driver's side dial to set the driver's

side temperature. Turn the front passenger's side dial to set the front passenger's side temperature.

#### When the “DUAL” mode is canceled:

Turn the driver's side dial to set the desired temperature.

When the “DUAL” mode is canceled, only the driver's side temperature is displayed.

## ■ Fan speed control

The fan operates only when the ignition switch is in the “ON” position. Turn the fan speed control dial to select the preferred fan speed.

## ■ Air conditioner control

The air conditioner operates only when the engine is running.

Press the air conditioner button while the fan is in operation to turn on the air conditioner. When the air conditioner is on, the “A/C” indicator light illuminates.

To turn off the air conditioner, press the button again.

### NOTE

**For efficient defogging or dehumidifying in cold weather, turn on the air conditioner. However, if the ambient temperature decreases to approximately 32°F (0°C), the air conditioner**



compressor may stop operating.

## ■ Air inlet selection

Select the air inlet by pressing the air inlet selection button.

### ● Recirculation:

When the indicator light on the air inlet selection button illuminates, interior air is recirculated inside the vehicle. Press the air inlet selection button to the ON position in the following cases.

- When driving on a dusty road
- When you want cooling performance to increase (for example, in particularly hot weather)

### ● Outside air circulation:

When the indicator light on the air inlet selection button does not illuminate, outside air is drawn into the passenger compartment. Press the air inlet selection button to the OFF position in the following cases.

- When the road is no longer dusty
- When the interior has cooled to a comfortable temperature



## WARNING

Continued operation in the ON position may fog up the windows. Switch to the OFF position as soon as the



outside conditions are no longer dusty.

## NOTE



**When the battery is disconnected or the battery voltage drops, the air inlet selection operation indicator light may blink. This does not indicate a malfunction. However, if the indicator light blinks every time you start the engine, a malfunction may occur in the electrical circuit. Have the vehicle inspected at the nearest SUBARU dealer.**

## Defrosting

Perform either of the following operations to defrost or to dehumidify the windshield and front door windows.

- Select the “” mode by pressing the defroster button (both types A and B).
- Select the “” mode by turning the airflow mode selection dial (type A).
- Select the “” mode by pressing the airflow mode selection button (type B).

## NOTE

**When the “” or “” mode is selected, the air conditioner compressor operates automatically regardless of the position of the air conditioner button to defrost the windshield more quickly. However, the indicator on the air conditioner button may not illuminate. At the same time, the air inlet selection is automatically set to the outside air mode. After defrosting the windshield by pressing the defroster button “”, pressing the button again returns the system to the setting that had been selected before the defroster was activated.**

## Operating tips for heater and air conditioner

### ■ Cleaning ventilation grille

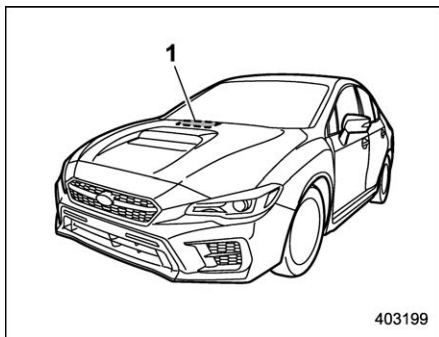

1) Front ventilation inlet grille

Always keep the front ventilation inlet grille free of snow, leaves, or other obstructions to ensure efficient heating and defrosting. Since the condenser is located in front of the radiator, this area should be kept clean because cooling performance is impaired by any accumulation of insects and leaves on the condenser.

### ■ Efficient cooling after parking in direct sunlight

After parking in direct sunlight, drive with the windows open for a few minutes to allow outside air to circulate into the heated interior. This results in quicker cooling by the air conditioner. Keep the windows closed during the operation of the air conditioner for maximum cooling efficiency.

### ■ Lubrication oil circulation in the refrigerant circuit

Operate the air conditioner compressor at a low engine speed (at idle or low driving speeds) a few minutes each month during the off-season to circulate its oil.

### ■ Checking air conditioning system before summer season

Check the air conditioner unit for refrigerant leaks, hose conditions, and proper operation each spring. Have the air conditioning system checked by your SUBARU dealer.

### ■ Cooling and dehumidifying in high humidity and low temperature weather conditions

Under certain weather conditions (high relative humidity, low temperatures, etc.) a small amount of water vapor emission from the air outlets may be noticed. This condition is normal and does not indicate any problem with the air conditioning system.

### ■ Air conditioner compressor shut-off when engine is heavily loaded

To improve acceleration and gas mileage, the air conditioner compressor is designed to temporarily shut off during air conditioner operation whenever the accelerator is fully depressed such as during rapid acceleration or when driving up a steep incline.

### ■ Refrigerant for your climate control system

Your air conditioner uses ozone friendly refrigerant R-1234yf (HFO-1234yf). Consult your SUBARU dealer for service. Repairs needed as a result of using the wrong refrigerant are not covered under warranty.

## Air filtration system

Your vehicle's air conditioning system is equipped with an air filtration system. Replace the cabin air filter element according to the replacement schedule found in the "Warranty and Maintenance Booklet". This schedule should be followed to maintain the filter's dust collection ability. Under extremely dusty conditions, the filter should be replaced more frequently. Have your filter checked or replaced by your SUBARU dealer. For replacement, use only a genuine SUBARU air filter kit.

### CAUTION

Contact your SUBARU dealer if the following occurs, even if it is not yet time to change the filter:

- Reduction of the airflow through the vents.
- Windshield gets easily fogged or misted.

### NOTE

The filter can influence the air conditioning, heating and defroster performance if not properly maintained.

## ■ Replacing the cabin air filter

1. Remove the glove box.

### NOTE

We recommend that you take measures to protect the center console with masking tape first, so that you avoid scratching the center console with the glove box.

- (1) Open the glove box.

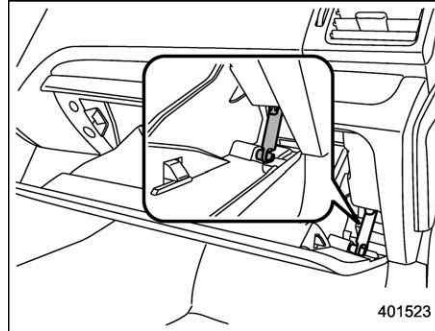

- (2) Remove the damper shaft from the glove box.

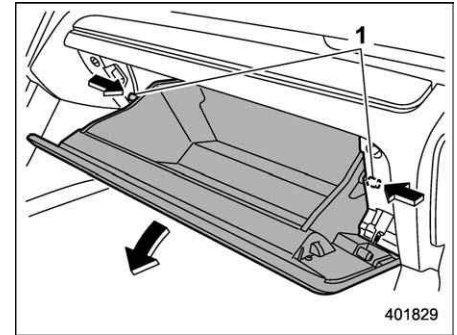

- 1) Stoppers

- (3) Push both sides of the glove box inside to unlock the stoppers and then pull down the glove box as far as it will go.

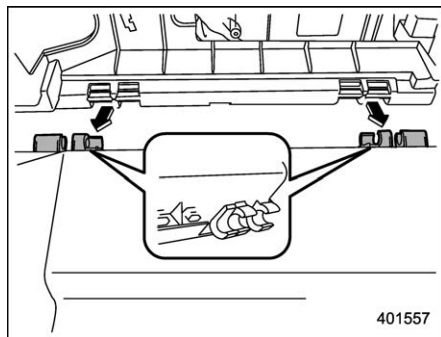

(4) Pull out the glove box horizontally and remove the hinge portion. When doing this, be careful not to damage the hinge.

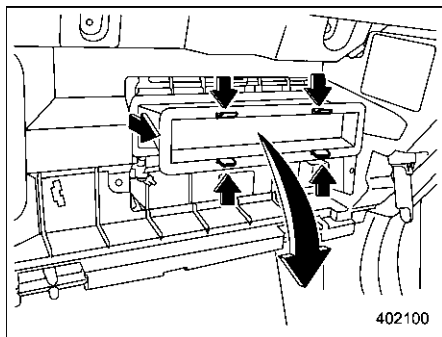

2. Remove the cabin air filter according to the following procedure in order to prevent dust on the air cleaner from falling to the inside of its housing.

(1) Push in the four stoppers to unlock, and then slowly pull out the filter 4 in (10 cm) from the housing.

(2) Completely pull out the filter by gently tilting the front side of the filter downward.

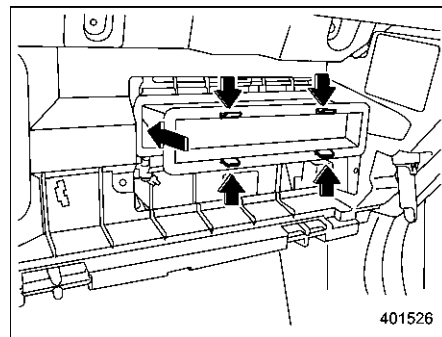

3. Replace the cabin air filter element with a new one.

**CAUTION**

**The arrow mark on the filter must point UP.**

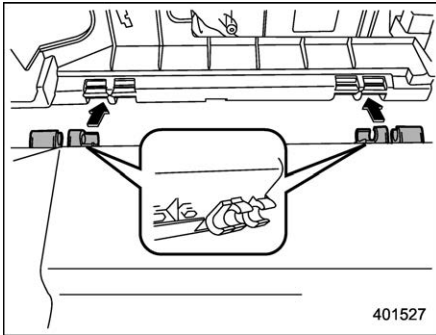

4. Reinstall the glove box, and connect the damper shaft.
5. Close the glove box.

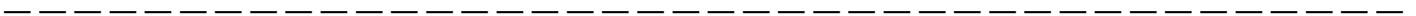
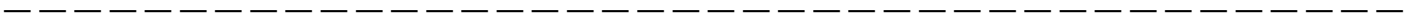
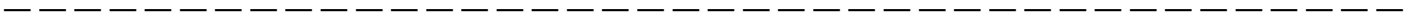
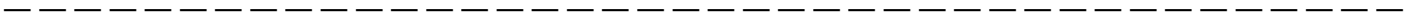
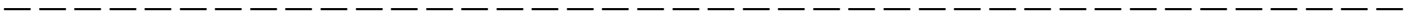
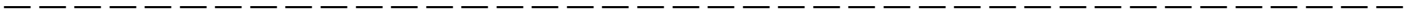
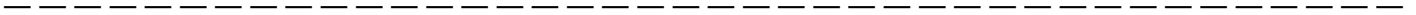
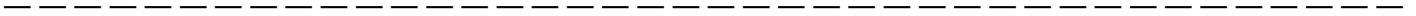
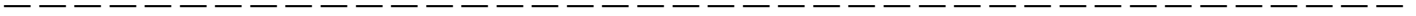

Antenna .....	5-2
Roof antenna .....	5-2

Audio set.....	5-2
----------------	-----

## Antenna

### ■ Roof antenna

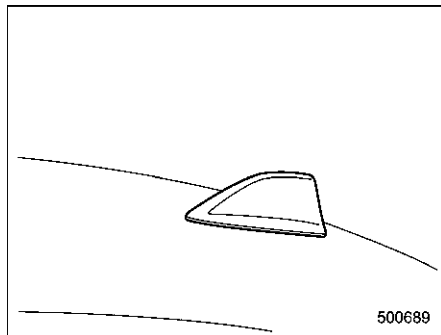

The shark-fin type roof antenna is installed in the center at the rear of the roof.

## Audio set

If your vehicle is equipped with a genuine SUBARU navigation system or audio system, refer to the separate navigation/audio Owner's Manual for details.



<b>Interior lights</b> .....	<b>6-2</b>
Dome light.....	6-2
Map lights.....	6-2
OFF delay timer.....	6-3
<b>Sun visors</b> .....	<b>6-3</b>
Sun visor extension plate (models with the EyeSight system).....	6-4
Vanity mirror with light.....	6-4
<b>Storage compartment</b> .....	<b>6-5</b>
Glove box.....	6-5
Center console.....	6-5
<b>Cup holders</b> .....	<b>6-6</b>
Front passenger's cup holder.....	6-6
Rear passenger's cup holder.....	6-7
<b>Bottle holders</b> .....	<b>6-7</b>

<b>Accessory power outlets</b> .....	<b>6-8</b>
Use with a cigarette lighter (if equipped).....	6-9
<b>USB power supply</b> .....	<b>6-10</b>
How to use the USB power supply.....	6-10
<b>Ashtray (if equipped)</b> .....	<b>6-11</b>
<b>Floor mat (if equipped)</b> .....	<b>6-11</b>
<b>Assist grip</b> .....	<b>6-12</b>
<b>Coat hook</b> .....	<b>6-13</b>
<b>Under-floor storage compartment</b> .....	<b>6-13</b>
<b>Rear view camera</b> .....	<b>6-14</b>
<b>Front View Monitor (if equipped)</b> .....	<b>6-14</b>
How to access the Front View Monitor.....	6-15
How to cancel the Front View Monitor.....	6-15
Range of image on screen.....	6-16
Guiding line.....	6-17
Handling of camera.....	6-17

## Interior lights

### CAUTION

When leaving your vehicle, make sure the lights are turned off to avoid battery discharge.

### ■ Dome light

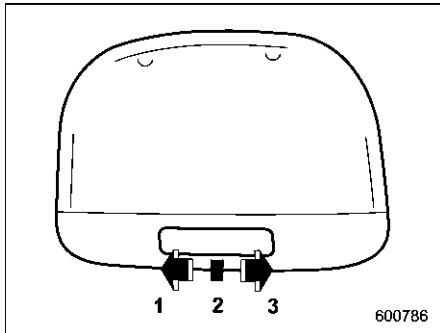

- 1) ON
- 2) DOOR
- 3) OFF

The dome light switch has the following three positions.

**ON:** The light remains on continuously.  
**OFF:** The light remains off.

**DOOR:** The dome light illuminates automatically after any of the following operations.

- Opening any of the doors.
- Unlocking the doors using the keyless access function (if equipped). Refer to “Unlocking” 2-11.
- Unlocking the doors using the remote keyless entry system. Refer to “Remote keyless entry system” 2-18.
- Turning the ignition switch from the “ACC” position to the “LOCK”/“OFF” position.

### ■ Map lights

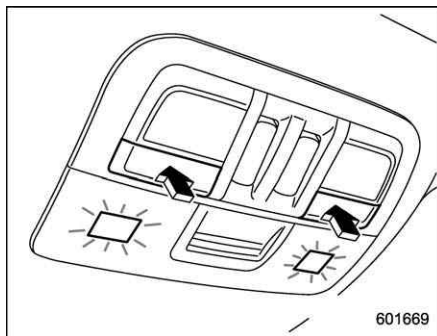

Type A

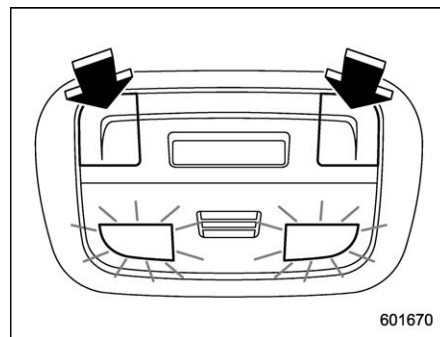

Type B

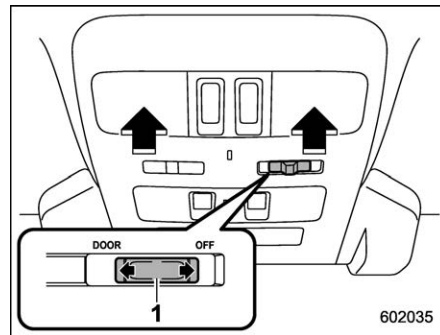

Type C

- 1) Door interlock switch

To turn on the map light, push the switch.  
 To turn it off, push the switch again.

### ▼ Automatic illumination (type A map lights)

The map lights illuminate automatically in the following cases.

- Any of the doors is opened.
- The doors are unlocked using the keyless access function (if equipped). Refer to “Unlocking” 2-11.
- The doors are unlocked using the remote keyless entry transmitter.
- The ignition switch is turned from the “ACC” position to the “LOCK”/“OFF” position.

### ▼ Automatic illumination (type C map lights)

When the door interlock switch is in the “DOOR” position, the map lights illuminate automatically in the following cases.

- Any of the doors other than the trunk is opened.
- The doors are unlocked using the keyless access function (if equipped). Refer to “Locking and unlocking by holding the access key fob” 2-10.
- The doors are unlocked using the remote keyless entry system. Refer to “Remote keyless entry system” 2-18.
- The ignition switch is turned from the “ACC” position to the “LOCK”/“OFF” position.

### ■ OFF delay timer

The following lights have an automatic illumination function.

- Dome light (when the dome light switch is in the “DOOR” position)
- Map light (type A)
- Type C map light (when the map light switch is in the “DOOR” position)

After being illuminated automatically, these lights remain on for several seconds and then gradually turn off after all doors are closed.

While the lights are illuminated, the lights turn off immediately after any of the following operations.

- Turning the ignition switch from the “LOCK”/“OFF” position to the “ACC” or “ON” position.
- Locking all doors using the keyless access function (if equipped).
- Locking all doors using the remote keyless entry system.

The setting for the period of time in which the lights remain on (OFF delay timer) can be changed by a SUBARU dealer. Contact your SUBARU dealer for details. Also, the setting can be changed by operating the multi-function display (color LCD). For details, refer to “Interior light setting” 3-62.

## Sun visors

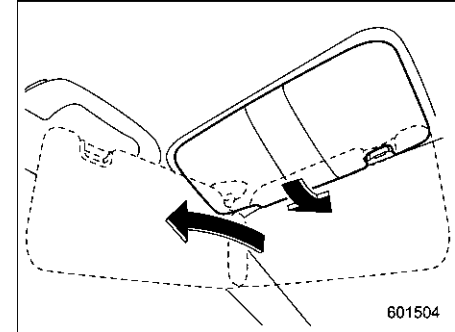

To block out glare, swing down the visors. To use the sun visor at a side window, swing it down and move it sideways.

■ Sun visor extension plate (models with the EyeSight system)

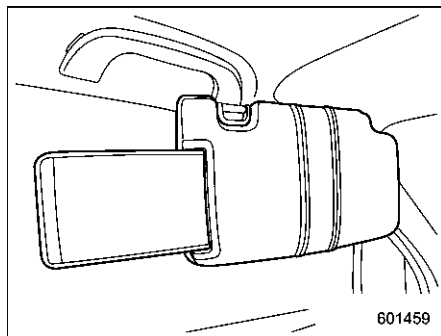

601459

With the sun visor positioned over the side window, you can use the sun visor extension plate to prevent glare through the gap between the sun visor and center pillar. To use the extension plate, pull it toward the rear of the vehicle. When you have finished using it, stow it by pushing it toward the front of the vehicle.

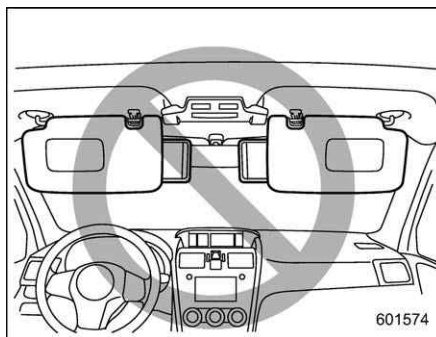

601574

▲ CAUTION

**Do not pull out the extension plate with the sun visor positioned over the windshield. The extension plate would obstruct your view of the rear view mirror.**

■ Vanity mirror with light

▲ CAUTION

**Keep the vanity mirror cover closed while the vehicle is being driven to avoid being temporarily blinded by the glare of bright light.**

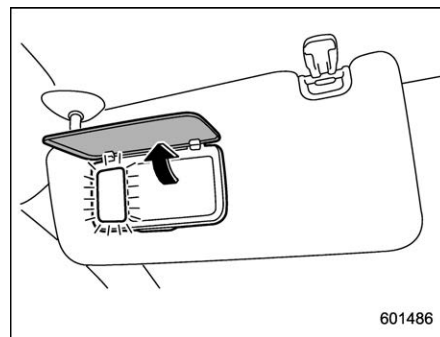

601486

To use the vanity mirror, swing down the sun visor and open the vanity mirror cover. The light beside the vanity mirror illuminates when the mirror cover is opened.

**NOTE**

**Do not use the vanity mirror light for a long period of time while the engine is not running. Doing so can cause battery discharge.**

## Storage compartment

### ⚠ CAUTION

- Always keep the storage compartment closed while driving to reduce the risk of injury in the event of a sudden stop or an accident.
- Do not store spray cans, containers with flammable or corrosive liquids or any other dangerous items in the storage compartment.

## ■ Glove box

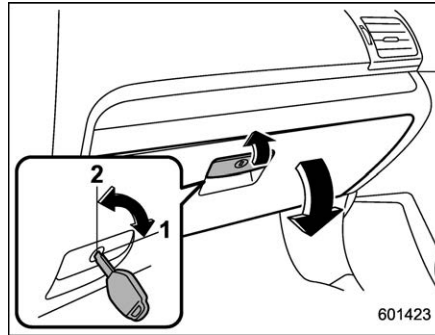

- 1) Rotate the key clockwise to lock.
- 2) Rotate the key counterclockwise to unlock.

To open the glove box, pull the handle.  
To close it, push the lid firmly upward.

### NOTE

- For models with the “keyless access with push-button start system”, use the emergency key to lock or unlock the glove box.
- The emergency key is directional. If the key cannot be inserted, change the direction that the grooved side is facing and insert it again.

## ■ Center console

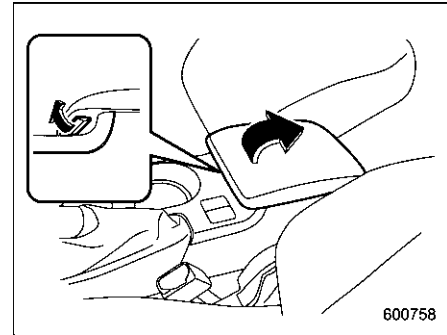

To open the lid, pull up the lock release.

## Cup holders

**CAUTION**

Take care to avoid spills. Beverages, if hot, might burn you and/or your passengers. Spilled beverages may also damage upholstery, carpets or audio equipment.

### ■ Front passenger's cup holder

**CAUTION**

Do not pick up a cup from the cup holder or put a cup in the holder while driving. Doing so can distract you and lead to an accident.

#### ▼ Except STI

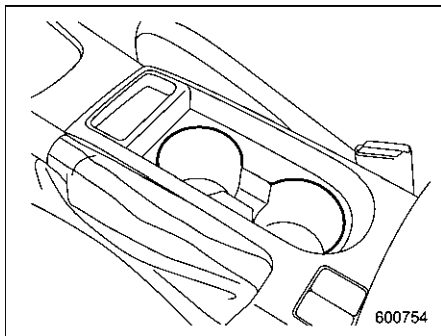

Type A

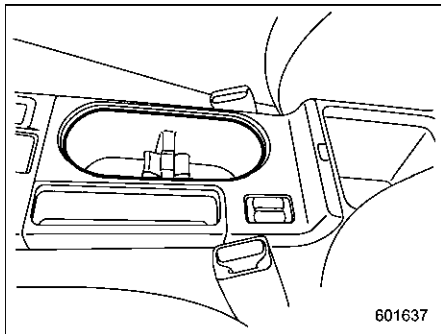

Type B

A dual cup holder is built into the center console.

#### ▼ STI

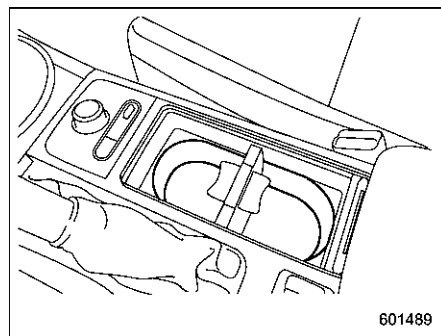

The dual cup holder is built into the center console near the parking brake lever.

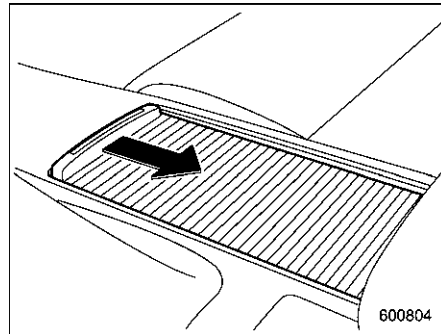

To access the cup holder, pull the lid toward the rear.

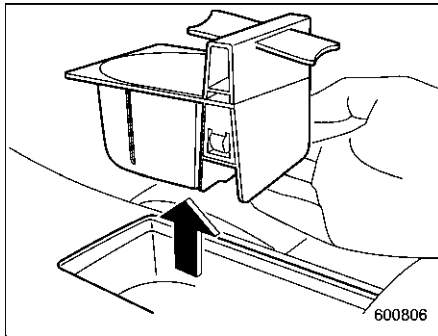

You can pull out the divider in the cup holder and insert it in a different position (further toward the front or rear) to enable cups of different sizes to be held.

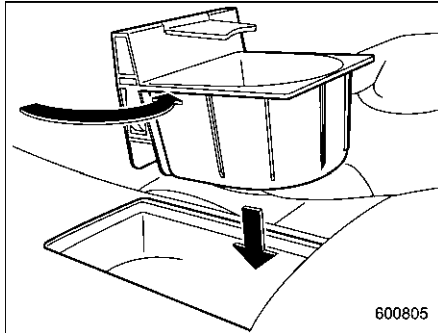

## NOTE

With the divider taken out, you can use the cup holder as a storage box.

### ■ Rear passenger's cup holder

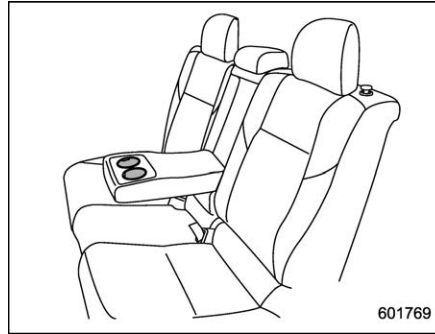

A dual cup holder is built into the armrest.

## CAUTION

When a cup containing a beverage is in the cup holder, do not fold down the rear seats. Otherwise, the beverage could spill while driving, and if the beverage is hot, it could burn you and/or your passengers.

## Bottle holders

### CAUTION

- Do not pick up a bottle from the bottle holder or put a bottle in the holder while driving. Doing so can distract you and lead to an accident.
- When placing a beverage in a bottle holder, make sure it is capped. Otherwise, the beverage could spill when opening/closing the door or while driving and, if the beverage is hot, it could burn you and/or your passengers.

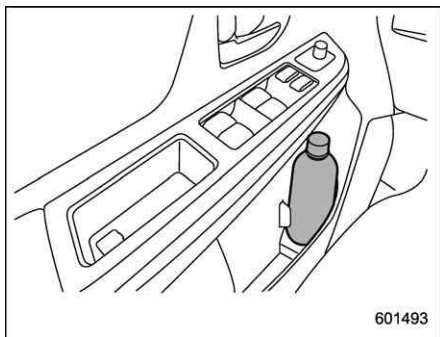

You can use the bottle holder equipped on each door trim to hold a beverage bottle and other items.

## Accessory power outlets

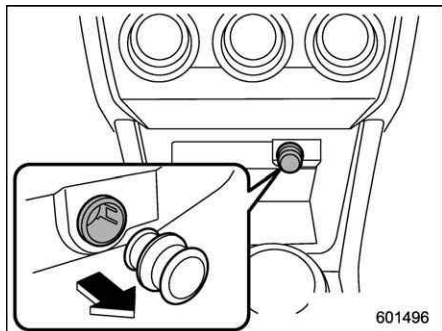

Power outlet below the climate control dials

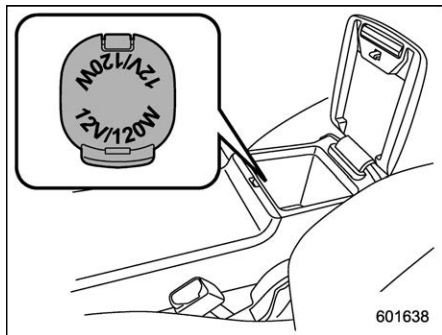

Power outlet in the center console

Accessory power outlets are provided

below the climate control dials and in the center console. Electrical power (12 V DC) from the battery is available at any of the outlets when the ignition switch is in either the "ACC" or "ON" position.

You can use an in-vehicle electrical appliance by connecting it to an outlet.

The maximum power rating of an appliance that can be connected is **120 W**. Do not use an appliance which exceeds the indicated wattage for each outlet.

When using appliances connected to two or more outlets simultaneously, the total power consumed by them must not exceed 120 W.

### CAUTION

- Do not attempt to use a cigarette lighter in the accessory power outlets.
- Do not place any foreign objects, especially metal ones such as coins or aluminum foil, into the accessory power outlet. That could cause a short circuit. Always put the cap on the accessory power outlet when it is not in use.
- Use only electrical appliances which are designed for 12 V DC. The maximum power rating of an



appliance that can be connected is 120 W. Do not use an appliance which exceeds the indicated wattage for each outlet.

When using appliances connected to two or more outlets simultaneously, the total power consumed by them must not exceed 120 W. Overloading the accessory power outlet can cause a short circuit. Do not use double adapters or more than one electrical appliance.

- If the plug on your electric appliance is either too loose or too tight for the accessory power outlet, this can result in a poor contact or cause the plug to get stuck. Only use plugs that fit properly.
- Use of an electric appliance in the accessory power outlet for a long period of time while the engine is not running can cause battery discharge.
- Before driving your vehicle, make sure that the plug and the cord on your electrical appliance will not interfere with your shifting gears and operating the accelerator and brake pedals. If they do, do

not use the electrical appliance while driving.

### ■ Use with a cigarette lighter (if equipped)

To use the accessory power outlet as a cigarette lighter socket, purchase the cigarette lighter plug, which is an optional accessory. A cigarette lighter plug is available from your SUBARU dealer.

The cigarette lighter operates only when the ignition switch is in the "ON" or "ACC" position.

To use the cigarette lighter, push in the knob and wait a few moments. It will automatically spring up when ready for use.

### WARNING

To avoid being burned, never grasp the lighter by the end with the heating element. Doing so could result in injury and could also damage the heating element.

### CAUTION

- Do not hold the lighter pushed in, because it will overheat.
- The electrical power socket is originally designed to use a genuine SUBARU cigarette lighter plug. Do not use a non-genuine cigarette lighter plug in the socket. Doing so may cause a short-circuit and overheating, resulting in a fire.
- If the socket is ever used for a plug-in accessory such as a cell phone, that may damage the portion of the socket's internal mechanism that causes a cigarette lighter plug to "pop out" after its lighter element is heated. Therefore, do not place a cigarette lighter plug in a socket that has been used, even once, to power a plug-in accessory. Doing so may cause the plug to stick and overheat, creating a potential fire hazard.

## USB power supply

### CAUTION

- The specification of a USB terminal that can be used is the A-type. If a different specification of terminal is connected, power supply or charging may not be possible, or the device may malfunction.
- There is a risk that a connected device may malfunction or data may be damaged. The connection of a device shall be performed at your responsibility.
- To avoid an electric shock or a malfunction, observe the following precautions.
  - Do not connect a USB hub.
  - Do not insert any metal or other foreign object into the USB terminal.
  - Do not spill water or other liquid on the USB terminal.
- Be careful not to pull the connected cable. Doing so could break the USB terminal and the connected device.

- If a device is connected for a long time when the engine is not running, the battery may be discharged. Even when the engine is running, we recommend that you do not connect a device for an unnecessarily long time.
- Do not connect a malfunctioning device. Doing so may cause the risk of smoke and fire.

### NOTE

- The rated voltage of each USB terminal is DC 5 V/2.1 A (total 4.2 A). Before connecting a device, be sure to read the instruction manual of the device and check whether or not this specification of the output is supported by the device. If a device that requires power exceeding the maximum rating is connected, power supply or charging may not be possible. Even if charging could be completed, the time required for charging may be longer than when the genuine charger for that device is used.
- Depending on the device, charging may be possible only when a special cable is used. In this case, be sure to connect the device using the special cable.

- When a device that communicates with a PC is connected, power supply or charging may not be possible.
- When connect a device for charging, disconnect the device promptly after charging is completed.

### ■ How to use the USB power supply

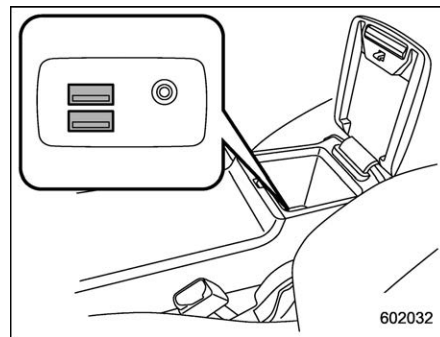

Front seat USB power supply (You can connect and use an audio device)

Use the USB terminal to use or charge an electronic device.

When the ignition switch is in the “ACC” or “ON” position, the power can be supplied to the electronic device. Up to DC 5 V/2.1 A can be supplied from each terminal (total of 4.2 A).

## Ashtray (if equipped)

### ⚠ CAUTION

Observe the following precautions. Not doing so could result in a fire.

- Always extinguish matches and cigarettes before putting them into the ashtray, and then close the ashtray securely.
- Do not put flammable material in the ashtray.
- Do not leave a lighted cigarette in the ashtray.
- Do not leave a lot of cigarette butts in the ashtray.

### NOTE

Particles of ash and tobacco will accumulate around the hinges of the ashtray's inner lid. Clean them off using a toothbrush or a similar narrow-ended implement.

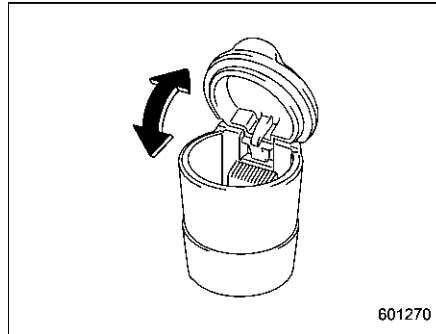

You can install the portable ashtray in each cup holder or bottle holder. For the locations of the cup holders, refer to "Cup holders" ¶6-6. For the locations of the bottle holders, refer to "Bottle holders" ¶6-7.

When using the ashtray, open the lid of the ashtray. Fully close the lid after using the ashtray to help reduce residual smoke.

## Floor mat (if equipped)

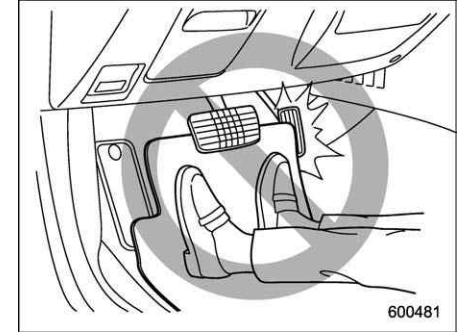

### ⚠ CAUTION

If the floor mat slips forward and interferes with the movement of the pedals while driving, it could cause an accident. Observe the following precautions to prevent the floor mat from slipping forward.

- Be sure to use a genuine SUBARU floor mat or an equivalent designed with grommets in the correct locations.
- Make sure that the driver's floor mat is placed in its proper location and is correctly secured on its retaining pins.

## 6-12 Interior equipment/Assist grip

- Do not use more than one floor mat.

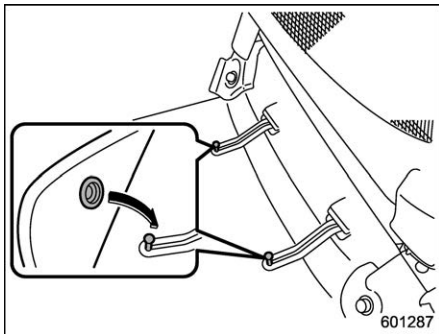

Retaining pins are located on the driver's side floor.

Properly secure the floor mat using the built-in grommets, by placing the grommets over the pins and pushing them downward.

### Assist grip

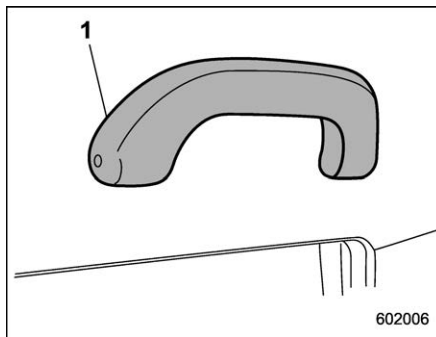

1) Assist grip

The assist grip is to be held to support the body of the passengers when they are in the seat and the vehicle is moving.

### WARNING

**Do not hold the assist grip when getting up from the seat. Holding and pulling the assist grip in the wrong way could break the grip and possibly cause injury.**

### CAUTION

**Do not attach heavy objects to the assist grip. Doing so could break it and damage the object.**

## Coat hook

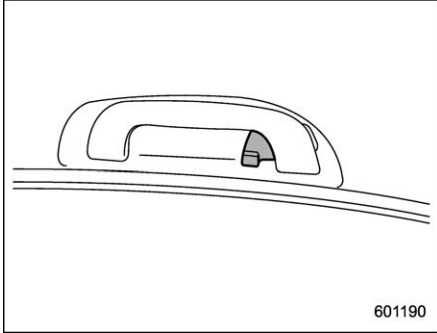

601190

The coat hook is attached to each rear passenger's assist grip.

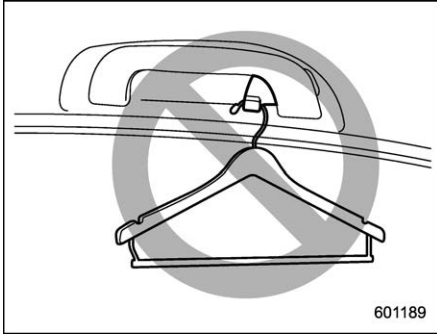

601189

### WARNING

Observe the following instructions.

- Do not hang coat hangers or other hard or pointed objects on the coat hooks. Hang clothing directly on the coat hooks without using hangers.
- Before hanging clothing on the coat hooks, make sure there are no pointed objects in the pockets.

If these instructions are ignored, the following may occur in sudden stops or collisions, causing serious injuries.

- Items may be thrown through the cabin.
- SRS curtain airbags may be prevented from deploying properly.

### CAUTION

Never hang anything on the coat hook that might obstruct the driver's view or that could cause injury in sudden stops or in a collision. And do not hang items on the coat hook that weigh 11 lbs (5 kg) or more.

## Under-floor storage compartment

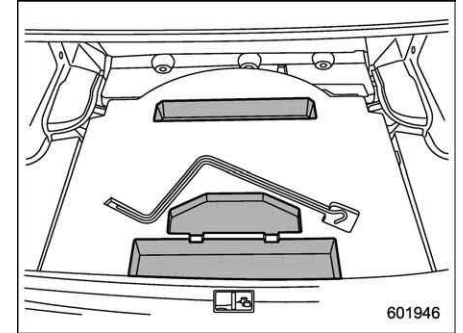

601946

The storage compartment is located under the floor of the trunk and can be used to store small items. Pull the strap to open the trunk floor lid, and then remove the lid.

### NOTE

- The shape of the storage compartment may be different depending on the model.
- When storing a flat tire, put the storage tray in the trunk.

### CAUTION

- Always keep the lids closed while driving to reduce the risk of injury

in the event of a sudden stop or an accident.

- **Do not store spray cans, containers with flammable or corrosive liquids or any other dangerous items in the storage compartment.**

## Rear view camera

Refer to the separate navigation/audio Owner's Manual.

## Front View Monitor (if equipped)

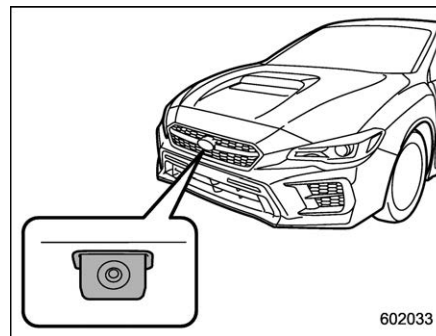

The image from the camera mounted inside the front grille is displayed in the multi-function display (color LCD). This eliminates blind spots and allows the driver to check the forward direction of both sides.

### **WARNING**

- **Never rely on only the Front View Monitor when driving the vehicle. The image on the monitor screen may be different from the actual situation. If you drive the vehicle by viewing only the monitor image, a collision or an unexpected**

accident may occur. When driving the vehicle, always check the traffic around the vehicle directly with your eyes and the mirrors.

- Always operate the vehicle as you would without the Front View Monitor.
- Do not use the Front View Monitor in the following situations.
  - You are driving on a dirt road or a road covered in snow.
  - The camera malfunctions (e.g. the lens or bracket is broken).
- If the outside temperature is low, the monitor screen may become dark or the image may become dim. In particular, the image of a moving object may be distorted or disappear from the screen. You must always check the traffic around the vehicle directly with your eyes when driving it.

## ■ How to access the Front View Monitor

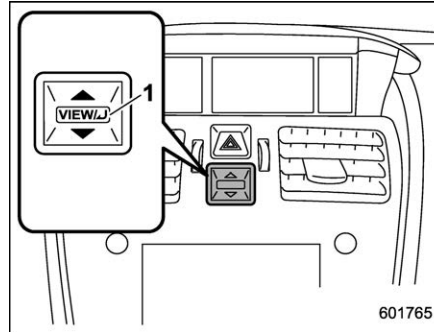

1) VIEW switch

To change over to the camera screen, perform either of the following operations when the ignition switch is in the "ON" position.

- Press the VIEW switch.
- Shift the select lever from "R" to "D" (only when the Camera Shift Link is set to "On") (for details, refer to "Camera shift link setting" 3-58.)

## ■ How to cancel the Front View Monitor

### ▼ Manual cancellation

Press the VIEW switch again.

### ▼ Automatic cancellation

If any of the following conditions are met, the Front View Monitor is canceled automatically.

### After accessing the Front View Monitor by pressing the VIEW switch:

- Approximately 3 minutes have passed since the last operation.
- The vehicle speed becomes 12.5 mph (20 km/h) or more.
- The select lever (CVT models) is shifted to the "P" position.
- The parking brake is applied.

### After accessing the Front View Monitor by using the select lever:

- Shift the select lever into the "P" position.
- The vehicle speed becomes 5 mph (8 km/h) or more.
- Approximately 9 seconds have passed since the last operation.
- The parking brake is applied.

## ■ Range of image on screen

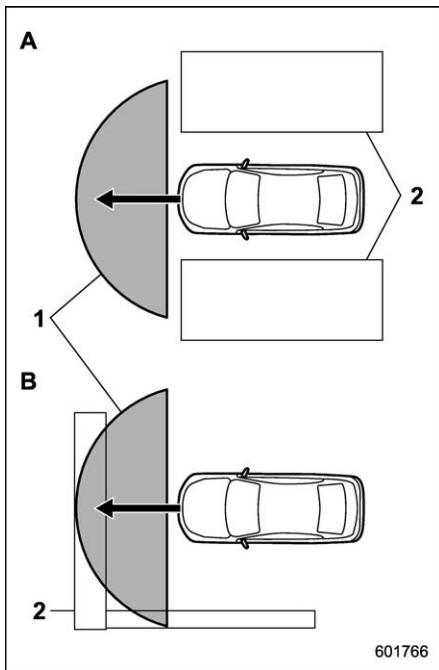

- A) Traffic intersection with a poor visibility view  
 B) Parking facing a wall  
 1) Range of displayed image  
 2) Obstacles (e.g., buildings, fences or other vehicles)



### WARNING

Because the range of the image captured by the camera is limited, always check the traffic around the vehicle directly with your eyes when driving the vehicle.

### NOTE

- The range of the displayed image may differ depending on the vehicle status or the road surface status.
- Because the Front View Monitor system uses a specially designed lens, the sense of distance in the displayed image is different from the actual distance.
- The camera image may be difficult to view in the following situations. This is not a malfunction.
  - Dark place (at night)
  - High or low temperature around the lens
  - Water contacts lens or in high humidity (rainy weather)
  - There are foreign materials (such as mud) around the camera
  - Sunlight or headlight beam directly shines towards the camera lens
- Under an artificial light such as a

fluorescent lamp, sodium-vapor lamp or mercury lamp, the lighted portion may look like it is flickering (flicker phenomenon).

- While the display has cooled down, the image may leave traces or become darker than usual, causing a difficulty in viewing the screen. Always check the traffic around the vehicle directly with your eyes while driving the vehicle.
- The following incidents should not be deemed a malfunction.
  - The camera lens may become foggy when the humidity is high on a rainy day.
  - The light from a vehicle or building located ahead may be reflected towards the camera image while driving at night.
  - In a dark place or while driving at night, the camera image may be adjusted to make noises less visible. Therefore, the image may look like a monochromatic image or the image colors may differ from the actual colors. The camera image may be deteriorated in regard to sharpness at the center and four corners of the screen. This is not a malfunction.



## ■ Guiding line

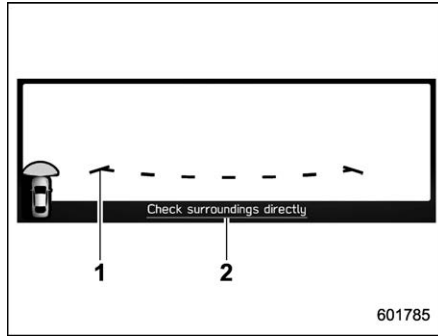

- 1) Guiding line
- 2) Warning message

The guiding line that indicates the width and the front end of your vehicle is displayed on the display.

## ■ Handling of camera

### ⚠ CAUTION

Observe the following instructions. Otherwise, the system may malfunction.

- Do not apply any strong impact to the camera such as banging it or hitting it with an object. The mounting angle may change.
- The camera unit is a waterproof structure. Do not attempt to remove, disassemble or modify the unit.
- Do not rub strongly or polish the camera lens with a hard brush or abrasive compounds. The lens may be scratched resulting in an adverse effect to the camera image.
- The camera lens is made of glass or plastic. Do not allow any organic solvent, body wax, oil film remover or glass coating agent to become attached on the lens surface. If any becomes attached, remove it immediately.
- Do not expose the camera lens to any sudden temperature change, for example, spraying hot water

on it in cold weather.

- Do not apply the water jet of a high pressure washer to the camera or the surrounding area when cleaning the vehicle. The impact by the strong water pressure may cause the camera to come off. Also, water may enter inside the camera and cause a malfunction.
- If the camera is exposed to any impact, it may lead to malfunction of the camera. Have the camera inspected by your SUBARU dealer as soon as possible.
- Do not use a steam cleaner under any circumstances. Some types of steam cleaners inject hot steam.
- The camera surface may be damaged by a flying stone.

## NOTE

If the camera lens is contaminated, no sharp image is available. When the camera is contaminated with water drops, snow or mud, wash it with water and wipe away any moisture with a soft cloth. If it heavily gets dirty, wash it with a neutral detergent.

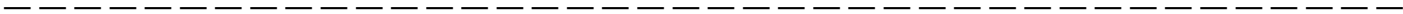
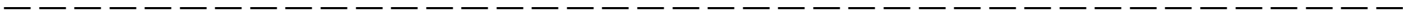
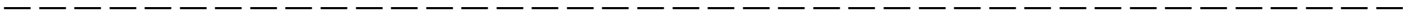
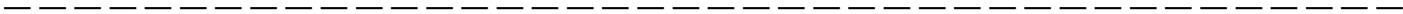
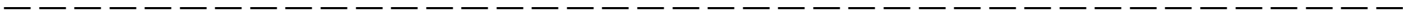
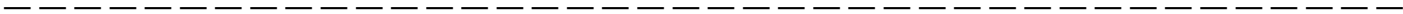
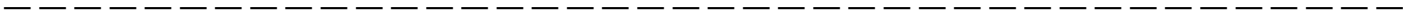
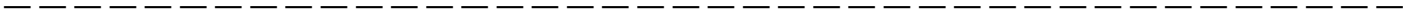
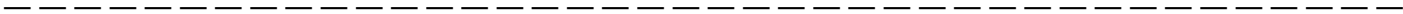
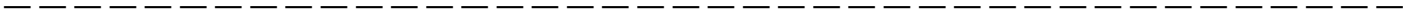
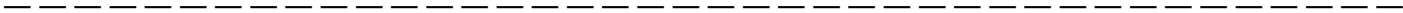
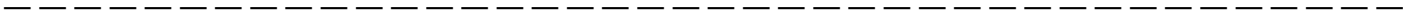
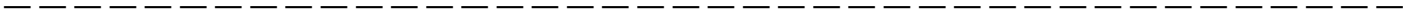

<b>Fuel</b> .....	7-3
Fuel requirements .....	7-3
Fuel filler lid and cap .....	7-5
<b>State emission testing (U.S. only)</b> .....	7-7
<b>Preparing to drive</b> .....	7-8
<b>Starting and stopping the engine</b> .....	7-9
General precautions when starting/stopping engine .....	7-9
Models without push-button start systems .....	7-10
Steering lock .....	7-11
Models with push-button start systems .....	7-11
Steering lock .....	7-14
Remote engine start system (dealer option) .....	7-14
<b>Manual transmission</b> .....	7-16
Shifting speeds .....	7-17
Driving tips .....	7-18
<b>Driver's Control Center Differential (C.DIFF/DCCD) (STI)</b> .....	7-19
To change mode of driver's control center differential .....	7-19
Auto mode .....	7-20
Manual mode .....	7-21
Temporary release .....	7-22
<b>Continuously variable transmission</b> .....	7-23
Select lever .....	7-24
Selection of manual mode .....	7-25
Shift lock function .....	7-26
Driving tips .....	7-28
<b>SI-DRIVE (if equipped)</b> .....	7-28
Intelligent (I) mode .....	7-28
Sport (S) mode .....	7-29
Sport Sharp (S#) mode .....	7-29
SI-DRIVE switch .....	7-30
<b>Limited slip differential (LSD) (STI)</b> .....	7-31
<b>Power steering</b> .....	7-31
STI .....	7-31
Except STI .....	7-31
<b>Braking</b> .....	7-32
Braking tips .....	7-32
Brake system .....	7-33
Disc brake pad wear warning indicators .....	7-33
High performance brake system (Brembo equipped models) .....	7-34
<b>ABS (Anti-lock Brake System)</b> .....	7-34
ABS self-check .....	7-35
ABS warning light .....	7-35
<b>Electronic Brake Force Distribution (EBD) system</b> .....	7-35
Steps to take if EBD system malfunctions .....	7-36
<b>Vehicle Dynamics Control system</b> .....	7-37
Vehicle Dynamics Control system monitor .....	7-38
Vehicle Dynamics Control OFF switch .....	7-38
<b>Tire pressure monitoring system (TPMS) (U.S.-spec. models)</b> .....	7-40
<b>Parking your vehicle</b> .....	7-42
Parking brake (models without electronic parking brake system) .....	7-42
Electronic parking brake (models with electronic parking brake system) .....	7-42
Parking tips .....	7-45

<b>Auto Vehicle Hold function (models with electronic parking brake system)</b> .....	7-46
To turn on/off the Auto Vehicle Hold function .....	7-47
To operate the Auto Vehicle Hold function .....	7-47
To release the Auto Vehicle Hold function .....	7-48
Tips .....	7-48
<b>Hill start assist system</b> .....	7-49
To activate/deactivate the Hill start assist system .....	7-51
Hill start assist warning light/Hill start assist OFF indicator light (models without the electronic parking brake system) .....	7-52
<b>Cruise control</b> .....	7-53
To set cruise control .....	7-53
To temporarily cancel the cruise control .....	7-54
To turn off the cruise control .....	7-55
To change the cruising speed .....	7-55
Cruise control indicator .....	7-56
Cruise control set indicator .....	7-56
<b>BSD/RCTA (if equipped)</b> .....	7-56
System features .....	7-57
System operation .....	7-59
BSD/RCTA approach indicator light/warning buzzer .....	7-60
BSD/RCTA OFF indicator .....	7-62
BSD/RCTA warning indicator .....	7-62
BSD/RCTA OFF switch .....	7-63
Certification for the BSD/RCTA .....	7-63
Handling of radar sensors .....	7-65
<b>Reverse Automatic Braking (RAB) system (if equipped)</b> .....	7-66
Reverse Automatic Braking (RAB) system overview .....	7-66
Operating conditions .....	7-68
Reverse Automatic Braking (RAB) system operation .....	7-70
Canceling the Reverse Automatic Braking (RAB) system operation .....	7-74
Reverse Automatic Braking (RAB) system ON/OFF setting .....	7-74
RAB warning indicator .....	7-75
Handling of the sonar sensors .....	7-75

## Fuel

### CAUTION

**Use of a fuel which is low in quality or use of an inappropriate fuel additive may cause engine damage.**

### ■ Fuel requirements

#### ▼ STI

The engine is designed to operate at maximum performance using **unleaded gasoline** with an octane rating of **93 AKI (98 RON) or higher**. If 93 AKI (98 RON) fuel is not readily available in your area, unleaded gasoline with an octane rating of 91 AKI (95 RON) may be used with no detriment to engine durability or driveability. However, you may notice a slight decrease in maximum engine performance while using 91 AKI (95 RON) fuel. Use of 91 AKI (95 RON) fuel will not affect your warranty coverage.

#### ▼ Except STI

The engine is designed to operate using **unleaded gasoline** with an octane rating of **91 AKI (95 RON) or higher**. If 91 AKI (95 RON) fuel is not readily available, unleaded gasoline with an octane rating of

87 AKI (90 RON) may be used.

Regular unleaded gasoline with an octane rating of 87 AKI (90 RON) or higher may also be used. Using regular unleaded gasoline will not be detrimental to engine durability, nor will it affect your warranty coverage. However, depending on your driving habits and conditions, you may notice a decrease in maximum engine performance, fuel economy or slight engine vibration or knocking. If you experience any of these conditions while using a lower octane rated fuel, you may want to return to using 91 AKI (95 RON) octane rated fuel as soon as possible. Additionally, if your vehicle knocks heavily or persistently, the use of 91 AKI (95 RON) or higher grade unleaded gasoline is required.

#### ▼ Fuel octane rating

Using a gasoline with a lower octane rating can cause persistent and heavy knocking, which can damage the engine. Do not be concerned if your vehicle sometimes knocks lightly when you drive up a hill or when you accelerate. Contact your SUBARU dealer if you use a fuel with the specified octane rating and your vehicle knocks heavily or persistently.

#### ▼ RON

This octane rating is the Research Octane Number.

#### ▼ AKI

This octane rating is the average of the Research Octane and Motor Octane numbers and is commonly referred to as the Anti Knock Index (AKI).

#### ▼ Unleaded gasoline

The neck of the fuel filler pipe is designed to accept only an unleaded gasoline filler nozzle. Under no circumstances should leaded gasoline be used because it will damage the emission control system and may impair driveability and fuel economy.

#### ▼ Reformulated gasoline

SUBARU supports the use of reformulated gasoline when available. Reformulated gasoline has been blended to burn more cleanly and reduce vehicle emissions.

▼ MMT

Some gasoline contains an octane-enhancing additive called MMT (Methylcyclopentadienyl Manganese Tricarbonyl). If you use such fuels, your emission control system performance may deteriorate and the CHECK ENGINE warning light/Malfunction indicator light may turn on. If this happens, return to your authorized SUBARU Dealer for service. If it is determined that the condition is caused by the type of fuel used, repairs may not be covered by your warranty.

▼ Gasoline for cleaner air

Your use of gasoline with detergent additives will help prevent deposits from forming in your engine and fuel system. This helps keep your engine in tune and your emission control system working properly, and is a way of doing your part for cleaner air. If you continuously use a high quality fuel with the proper detergent and other additives, you should never need to add any fuel system cleaning agents to your fuel tank.

Many gasolines are now blended with materials called oxygenates. Use of these fuels can also help keep the air cleaner. Oxygenated blend fuels, such as ethanol (ethyl or grain alcohol) may be used in your vehicle, but should contain no more than

10% ethanol for the proper operation of your SUBARU.

Do not use any gasoline that contains more than 10% ethanol, including from any pump labeled E15, E30, E50 or E85 (which are only some examples of fuel containing more than 10% ethanol).

In addition, some gasoline suppliers are now producing reformulated gasolines, which are designed to reduce vehicle emissions. SUBARU approves the use of reformulated gasoline.

If you are not sure what the fuel contains, you should ask your service station operators if their gasolines contain detergents and oxygenates and if they have been reformulated to reduce vehicle emissions.

As additional guidance, only use fuels suited for your vehicle as explained in the following description.

- Fuel should be unleaded and have an octane rating no lower than that specified in this manual.
- Methanol (methyl or wood alcohol) is sometimes mixed with unleaded gasoline. Methanol can be used in your vehicle **ONLY** if it does not exceed 5% of the fuel mixture **AND** if it is accompanied by sufficient quantities of the proper cosol-

vents and corrosion inhibitors required to prevent damage to the fuel system. Do not use fuel containing methanol **EXCEPT** under these conditions.

- If undesirable driveability problems are experienced and you suspect they may be fuel related, try a different brand of gasoline before seeking service at your SUBARU dealer.
- Fuel system damage or driveability problems which result from the use of improper fuel are not covered under the SUBARU Limited Warranty.



**CAUTION**

**Do not let fuel spill on the exterior surfaces of the vehicle. Fuels containing alcohol may cause paint damage, which is not covered under the SUBARU Limited Warranty.**

## ■ Fuel filler lid and cap

### ▼ Refueling

Only one person should be involved in refueling. Do not allow others to approach the area of the vehicle near the fuel filler pipe while refueling is in progress.

Be sure to observe any other precautions that are posted at the service station.

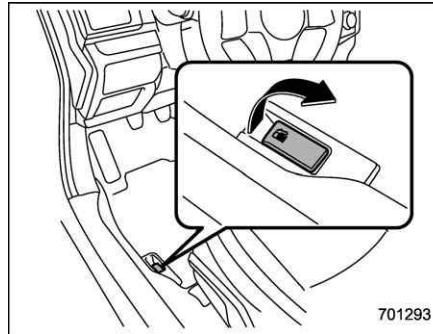
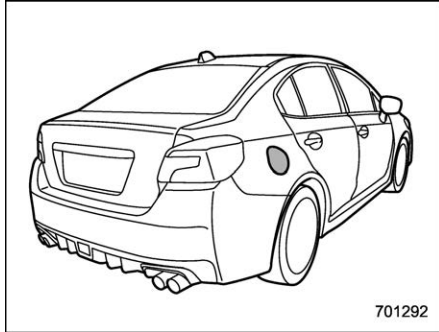

#### Fuel lid release lever

1. To open the fuel filler lid, pull the lid release lever up. The lever is on the floor at the left of the driver's seat.

### ⚠ WARNING

Before opening the fuel filler cap, first touch the vehicle body or a metal portion of the fuel pump or similar object to discharge any static electricity that may be present on your body. If your body is carrying an electrostatic charge, there is a possibility that an electric spark could ignite the fuel, which could burn you. To avoid acquiring a new static electric charge, do not get back into the vehicle while refueling

is in progress.

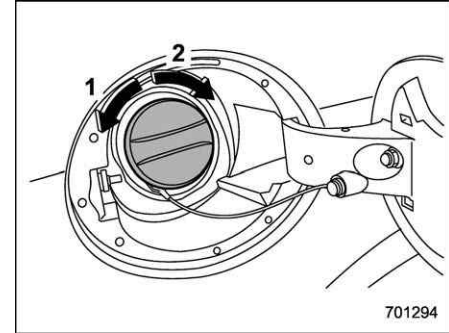

- 1) Open
- 2) Close

2. Remove the fuel filler cap by turning it slowly counterclockwise.

### ⚠ WARNING

- Gasoline vapor is highly flammable. Before refueling, always first stop the engine and close all vehicle doors and windows. Make sure that there are no lighted cigarettes, open flames or electrical sparks in the adjacent area. Only handle fuel outdoors. Quickly wipe up any spilled fuel.

- When opening the cap, grasp it firmly and turn it slowly to the left. Do not remove the cap quickly. Fuel may be under pressure and spray out of the fuel filler neck, especially in hot weather. If you hear a hissing sound while you are removing the cap, wait for the sound to stop and then slowly open the cap to prevent fuel from spraying out and creating a fire hazard.

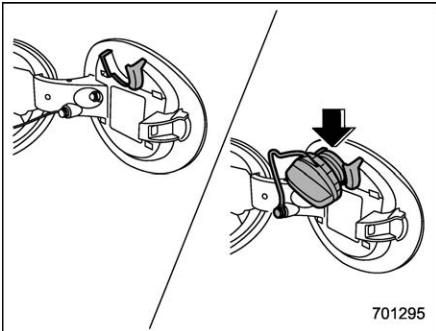

3. Set the fuel filler cap on the cap holder inside the fuel filler lid.

**WARNING**

- When refueling, insert the fuel nozzle securely into the fuel filler pipe. If the nozzle is lifted or not fully inserted, its automatic stopping mechanism may not function, causing fuel to overflow the tank and creating a fire hazard.
- Stop refueling when the automatic stop mechanism on the fuel nozzle activates. If you continue to add fuel, temperature changes or other conditions may cause fuel to overflow from the tank and create a fire hazard.

4. Stop filling the tank after the fuel filler pump automatically stops. Do not add any more fuel.
5. Put the cap back on, turn it clockwise until you hear a clicking noise. Be certain not to catch the tether under the cap while tightening.

**CAUTION**

**Make sure that the cap is tightened until it clicks to prevent fuel spillage in the event of an accident.**

6. Close the fuel filler lid completely.

**CAUTION**

If you spill any fuel on the painted surface, rinse it off immediately. Otherwise, the painted surface could be damaged.

**NOTE**

- You will see the “ ” sign in the fuel gauge. This indicates that the fuel filler lid is located on the right side of the vehicle.
- If the fuel filler cap is not tightened until it clicks or if the tether is caught under the cap, the CHECK ENGINE warning light/malfunction indicator light may illuminate. Refer to “CHECK ENGINE warning light/Malfunction indicator light” 3-16.

**CAUTION**

- Never add any cleaning agents to the fuel tank. The addition of a cleaning agent may cause damage to the fuel system.
- After refueling, turn the cap clockwise until it clicks to ensure that it is fully tightened. If the cap is not securely tightened, fuel may leak out while the vehicle is



being driven or fuel spillage could occur in the event of an accident, creating a fire hazard.

- Do not let fuel spill on the exterior surfaces of the vehicle. Because fuel may damage the paint, be sure to wipe off any spilled fuel quickly. Paint damage caused by spilled fuel is not covered under the SUBARU Limited Warranty.
- Always use a genuine SUBARU fuel filler cap. If you use the wrong cap, it may not fit or have proper venting and your fuel tank and emission control system may be damaged. It could also lead to fuel spillage and a fire.
- Immediately put fuel in the tank whenever the low fuel warning light illuminates. Engine misfires as a result of an empty tank could cause damage to the engine. Continuing to operate your vehicle at an extremely low fuel level may result in a reduction of engine performance.

## State emission testing (U.S. only)

### WARNING

Only use a four-wheel dynamometer when testing an All-Wheel Drive (AWD) model.

Testing of an AWD model must NEVER be performed on a single two-wheel dynamometer. Attempting to do so will result in uncontrolled vehicle movement and may cause an accident or injuries to persons nearby.

### CAUTION

- At state inspection time, remember to tell your inspection or service station in advance not to place your SUBARU AWD vehicle on a two-wheel dynamometer. Otherwise, serious transmission damage will result.
- Resultant vehicle damage due to improper testing is not covered under the SUBARU Limited Warranty and is the responsibility of the state inspection program or

its contractors or licensees.

California and a number of federal states have Inspection/Maintenance programs to inspect your vehicle's emission control system. If your vehicle does not pass this test, some states may deny renewal of your vehicle's registration.

Your vehicle is equipped with a computer that monitors the performance of the engine's emission control system. Certified emission inspectors will inspect the On-Board Diagnostic (OBDII) system as part of the state emission inspection process. The OBDII system is designed to detect engine and transmission problems that might cause the vehicle emissions to exceed allowable limits. OBDII inspections apply to all 1996 model year and newer passenger cars and trucks. Over 30 states plus the District of Columbia have implemented emission inspection of the OBDII system.

- The inspection of the OBDII system consists of a visual operational check of the "CHECK ENGINE" warning light/malfunction indicator light (MIL) and an examination of the OBDII system with an electronic scan tool.
- A vehicle passes the OBDII system inspection if proper operation of the "CHECK ENGINE" warning light is ob-

served, there are no stored diagnostic trouble codes, and the OBDII readiness monitors are all complete.

- A vehicle fails the OBDII inspection if the “**CHECK ENGINE**” warning light is not properly operating (light is illuminated or is not working due to faulty LED [Light Emitting Diode]) or there is one or more diagnostic trouble codes stored in the vehicle’s computer.

- A state emission inspection may reject (not pass or fail) a vehicle if the number of OBDII system readiness monitors “**NOT READY**” is greater than one. If the vehicle’s battery has been recently replaced or disconnected, the OBDII system inspection may indicate that the vehicle is not ready for the emission test. Under this condition, the vehicle driver should be instructed to drive his/her vehicle for a few days to reset the readiness monitors and return for an emission re-inspection.

- Owners of rejected or failing vehicles should contact their SUBARU Dealer for service.

Some states still use dynamometers in their emission inspection program. A dynamometer is a treadmill or roller-like testing device that allows your vehicle’s wheels to turn while the vehicle remains in one place. Prior to your vehicle being put

on a dynamometer, tell your emission inspector not to place your SUBARU AWD vehicle on a two-wheel dynamometer. **Otherwise, serious transmission damage will result.**

The U.S. Environmental Protection Agency (EPA) and states using two-wheel dynamometers in their emission testing program have EXEMPTED SUBARU AWD vehicles from the portion of the testing program that involves a two-wheel dynamometer. There are some states that use four-wheel dynamometers in their testing program. When properly used, this equipment should not damage a SUBARU AWD vehicle.

Under no circumstances should the rear wheels be jacked off the ground, nor should the driveshaft be disconnected in an attempt to bypass AWD for state emission testing. An AWD vehicles must be tested using an AWD dynamometer with all 4 wheels driven and loaded.

## **Preparing to drive**

---

You should perform the following checks and adjustments every day before you start driving.

1. Check that all windows, mirrors, and lights are clean and unobstructed.
2. Check the appearance and condition of the tires. Also check tires for proper inflation.
3. Look under the vehicle for any sign of leaks, and check that no small animal is under the vehicle.
4. Check that no small animal enters the engine compartment.
5. Check that the hood and trunk lid are fully closed.
6. Check the adjustment of the seat.
7. Check the adjustment of the inside and outside mirrors.
8. Fasten your seatbelt. Check that your passengers have fastened their seatbelts.
9. Check the operation of the warning and indicator lights when the ignition switch is turned to the “ON” position.
10. Check the gauges, indicator and warning lights after starting the engine.

**CAUTION**

Trapping small animals in the cooling fan and belts of the engine may result in a malfunction. Check that no small animal enters the engine compartment and under the vehicle before starting the engine.

**NOTE**

Engine oil, engine coolant, brake fluid, washer fluid and other fluid levels should be checked daily, weekly or at fuel stops.

**Starting and stopping the engine****■ General precautions when starting/stopping engine****WARNING**

- Never start the engine from outside the vehicle. It may result in an accident.
- Do not start the engine near dry foliage, paper, or other flammable substances. The exhaust pipe and exhaust emissions can create a fire hazard at high temperatures.
- Do not leave the engine running in locations with poor ventilation, such as a garage and indoors. The exhaust gas may enter the vehicle or indoors, and it may result in carbon monoxide poisoning.

**CAUTION**

- Do not stop the engine while driving. Otherwise, the catalyst may overheat and burn.
- When starting the engine, be sure

to sit in the driver's seat (except when using the remote engine start system).

**NOTE**

- Avoid rapid acceleration immediately after the engine has started. In addition, always avoid rapid racing.
- Until the engine is warmed up sufficiently, the engine speed is maintained high. The engine speed will gradually drop as the engine warms up.
- On rare occasions, it may be difficult to start the engine depending on the fuel used and the driving condition (repeated short trips when the engine is not warmed up sufficiently). In such cases, it is recommended to switch to a different brand of fuel.
- On rare occasions, transient knocking may be heard from the engine when the accelerator is operated rapidly such as a rapid start-up and a rapid acceleration. This is not a malfunction.
- The engine starts more easily when the headlights, air conditioner and rear window defogger are turned off.
- It may be difficult to start the engine when the battery has been disconnected and reconnected (for maintenance or other purposes). This difficulty is caused by the electronically

controlled throttle's self-diagnosis function. To overcome it, keep the ignition switch in the "ON" position for approximately 10 seconds before starting the engine.

### ■ Models without push-button start systems

#### ▼ Starting engine



**CAUTION**

Do not operate the starter motor continuously for more than 10 seconds. If the engine fails to start after operating the starter for 5 to 10 seconds, wait for 10 seconds or more before trying again.

#### NOTE

Do not shift the shift lever/select lever while the starter is cranking.

#### ▼ MT models

1. Apply the parking brake.
2. Turn off unnecessary lights and accessories.
3. Depress the clutch pedal to the floor and shift the shift lever into neutral. Hold the clutch pedal to the floor while starting the engine.

The starter motor will only operate when the clutch pedal is depressed fully to the floor.

4. Turn the ignition switch to the "ON" position and check the operation of the warning and indicator lights. Refer to "Warning and indicator lights" 3-13.

5. Turn the ignition switch to the "START" position **without** depressing the accelerator pedal. Release the key immediately after the engine has started.

If the engine does not start, perform the procedure described in "If the engine does not start" 7-10.

6. Confirm that all warning and indicator lights have turned off after the engine has started.

#### ▼ CVT models

1. Apply the parking brake.
2. Turn off unnecessary lights and accessories.
3. Shift the select lever to the "P" or "N" position (preferably the "P" position).

The starter motor will only operate when the select lever is at the "P" or "N" position.

4. Turn the ignition switch to the "ON" position and check the operation of the warning and indicator lights. Refer to "Warning and indicator lights" 3-13.

5. Turn the ignition switch to the "START"

position **without** depressing the accelerator pedal. Release the key immediately after the engine has started.

If the engine does not start, perform the procedure described in "If the engine does not start" 7-10.

6. Confirm that all warning and indicator lights have turned off after the engine has started.

While the engine is warming up, make sure that the select lever is at the "P" or "N" position and that the parking brake is applied.



**CAUTION**

If you restart the engine while the vehicle is moving, shift the select lever into the "N" position. Do not attempt to place the select lever of a moving vehicle into the "P" position.

#### ▼ If the engine does not start



**CAUTION**

For safety, release the accelerator pedal as soon as the engine starts.

Try the following procedure.

1. Turn the ignition switch to the "LOCK"

position and wait for at least 10 seconds.

2. After checking that the parking brake is firmly set, turn the ignition switch to the "START" position while depressing the accelerator pedal slightly (approximately a quarter of the full stroke).
3. If this fails to start the engine, turn the ignition switch back to the "LOCK" position and wait for at least 10 seconds.
4. Fully depress the accelerator pedal and turn the ignition switch to the "START" position.

If this fails to start the engine, try the following procedure.

1. Turn the ignition switch again to the "LOCK" position.
2. After waiting for 10 seconds or longer, turn the ignition switch to the "START" position without depressing the accelerator pedal.

If the engine still does not start, contact your nearest SUBARU dealer for assistance.

### ▼ Stopping the engine

The ignition switch should be turned off only when the vehicle is stopped and the engine is idling.



### WARNING

**Do not stop the engine when the vehicle is moving. This will cause loss of power to the power steering and the brake booster, making steering and braking more difficult. It could also result in accidental activation of the "LOCK" position on the ignition switch, causing the steering wheel to lock.**

### ■ Steering lock

After stopping the engine and the key is removed from ignition switch, the steering wheel will be locked due to the steering lock function.

When the engine is restarted, the steering lock will be automatically released.

### ▼ When the steering lock cannot be released

When you cannot unlock the steering wheel, perform the following steps.

1. Check that the parking brake is applied.
2. Turn off unnecessary lights and accessories.
3. Check that the select lever is set in the "P" position.
4. Depress the brake pedal and keep it

depressed.

5. Turn the ignition switch to the "ON" position while turning the steering wheel left and right.

If you cannot unlock the steering wheel by doing the steps, contact your nearest SUBARU dealer.

### ■ Models with push-button start systems

#### ▼ Safety precautions

Refer to "Safety precautions" 2-7.

#### ▼ Operating range for push-button start system

Refer to "Operating range" 3-6.

#### ▼ Starting engine



### WARNING

**If the indicator on the push-button ignition switch flashes in green after the engine has started, never drive the vehicle. The steering is still locked, and it may result in an accident. In this case, press the push-button ignition switch with the brake pedal depressed and with the steering wheel turned from the right to the left.**

**CAUTION**

- When the operation indicator on the push-button ignition switch is flashing in orange, there may be a malfunction with the vehicle. Contact a SUBARU dealer immediately.
- Do not continue pressing the push-button ignition switch for more than 10 seconds. Doing so could cause a malfunction. If the engine does not start, stop pressing the push-button ignition switch. Instead, press the push-button ignition switch without depressing the brake pedal to switch the power status to “OFF”. Wait 10 seconds, and then push the push-button ignition switch to start the engine.

**NOTE**

- When pressing the push-button ignition switch with the clutch pedal (MT models) or the brake pedal (CVT models) depressed:
  - The engine starter operates for a maximum of 10 seconds and after starting the engine, the starter stops automatically.

- You can start the engine regardless of the power status.
- If the engine does not start, check the security indicator light. Then press the push-button ignition switch without depressing the clutch pedal (MT models) or the brake pedal (CVT models) to switch the power to “OFF”.
  - If the light had illuminated, try to start the engine again.
  - If the light had been off, press the push-button ignition switch while depressing the clutch pedal (MT models) or the brake pedal (CVT models) more forcefully.
- The engine may not start depending on the radio wave conditions around the vehicle. In such a case, refer to “Starting engine” 9-19.
- If the vehicle battery is discharged, the steering cannot be unlocked. Charge the battery.
- Do not shift the shift lever/select lever while the starter is cranking.

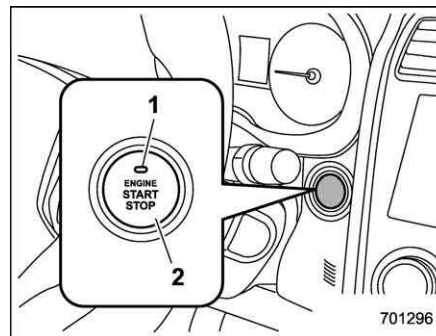

- 1) Operation indicator
- 2) Push-button ignition switch

The design of the push-button ignition switch may be slightly different depending on the models.

When you press the push-button ignition switch with the clutch pedal (MT models)/brake pedal (CVT models) depressed, the engine will start. The start procedure of the engine is as follows.

▽ **MT models**

1. Carry the access key fob, and sit in the driver's seat.
2. Apply the parking brake.
3. Shift the shift lever in neutral.
4. Depress the brake pedal.
5. Depress the clutch pedal until the indicator on the push-button ignition switch

turns green.

6. While depressing the clutch pedal, press the push-button ignition switch.

#### ▽ CVT models

1. Carry the access key fob, and sit in the driver's seat.
2. Apply the parking brake.
3. Shift the select lever in the "P" position. The engine can also start when the select lever is in the "N" position, however, for safety reasons, start in the "P" position.
4. Depress the brake pedal until the operation indicator on the push-button ignition switch turns green. When starting with the select lever in the "N" position, the indicator does not turn green.
5. While depressing the brake pedal, press the push-button ignition switch.

#### NOTE

- While pressing the select lever button in, the indicator on the push-button ignition switch will not turn green even when the select lever is in the "P" position.
- When the engine is not started, the brake pedal may feel stiff. In such a case, depress the brake pedal more forcefully than usual. Check that the operation indicator on the push-button

**ignition switch turns green, and press the push-button ignition switch to start the engine.**

#### ▽ In case of the engine does not start by the normal engine start procedure

1. Move the shift lever to the neutral position (MT models), or move the select lever to the "P" position (CVT models).
2. Switch the power status to "ACC".
3. Press and hold the push-button ignition switch for at least 15 seconds with the clutch pedal (MT models)/brake pedal (CVT models) depressed.

Although the engine may start, only use this procedure in the case of an emergency. If the engine still does not start, refer to "Starting engine" 9-19.

#### ▼ Stopping engine

1. Stop the vehicle completely.
2. Move the select lever to the "P" position (CVT models).
3. Press the push-button ignition switch. The engine will stop, and the power will be switched to "OFF".



#### WARNING

- Do not touch the push-button ignition switch while driving. When you operate the push-button ignition switch as follows, the engine will stop.
  - Pressing and holding the switch for 3 seconds or longer.
  - Pressing the switch briefly 3 times or more in succession.

When the engine stops, the brake booster will not function. A greater foot pressure will be required on the brake pedal.

The power steering system will not operate either. A greater force will be required to steer, and it may result in an accident.
- If the engine stops while driving, do not operate the push-button ignition switch or open any of the doors until the vehicle is stopped in a safe location. It is dangerous because the steering may be locked. Stop the vehicle in a safe location, and contact a SUBARU dealer immediately.

**CAUTION**

For CVT models:

- Do not stop the engine while the select lever is in a position other than the “P” position.
- If the engine is stopped while the select lever is in a position other than the “P” position, the power will be in “ACC”. If the vehicle is left in this condition, the battery may be discharged.

**NOTE**

Although you can stop the engine by operating the push-button ignition switch, do not stop the engine while driving except in an emergency.

▼ When access key fob does not operate properly

Refer to “Access key fob – if access key fob does not operate properly” 9-18.

■ **Steering lock**

After stopping the engine and the driver’s door is open, the steering wheel will be locked due to the steering lock function.

When the engine is restarted, the steering lock will be automatically released.

▼ When the steering lock cannot be released

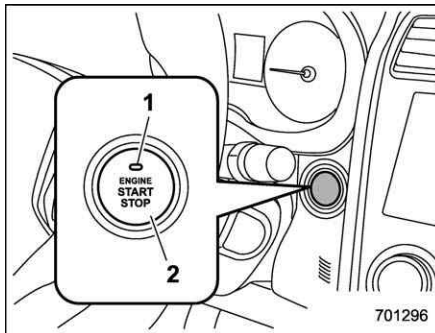

- 1) Operation indicator
- 2) Push-button ignition switch

When you cannot restart the engine due to the steering lock, check the status of operation indicator and perform the following steps.

▽ **Operation indicator flashing in green**

1. Check that the select lever is set in the “P” position.
2. Depress the brake pedal and keep it.
3. Press the push-button ignition switch while turning the steering wheel left and right.

▽ **Operation indicator flashing in orange**

There may be a malfunction in the steering lock function. Immediately contact your nearest SUBARU dealer.

■ **Remote engine start system (dealer option)**

**WARNING**

- Do not remote start a vehicle in an enclosed environment (e.g. closed garage). Prolonged operation of a motor vehicle in an enclosed environment can cause a harmful build-up of Carbon Monoxide. Carbon Monoxide is harmful to your health. Exposure to high levels of Carbon Monoxide can cause headaches, dizziness or in extreme cases unconsciousness and/or death.
- Before performing any servicing of the vehicle, temporarily place the remote engine start system in service mode to prevent the system from unexpectedly starting the engine.

The remote engine start system allows you to start the engine from outside the vehicle.



In addition, the remote engine start system can activate the heater or air conditioner, providing you with a comfortable cabin upon entry.

## NOTE

The length of time for which it is acceptable to allow the engine to remain idling may be governed by local laws and regulations. Check the local rules when using the remote engine start system.

### ▼ Models with “keyless access with push-button start system”

## NOTE

For more details, refer to the Owner’s Manual supplement for the remote engine start system.

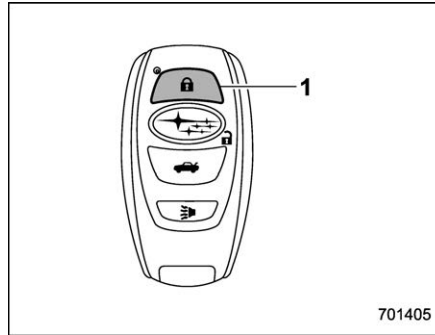

**Access key fob**

- 1) Lock button

An access key fob serves as the remote engine start transmitter. Operate the lock button to start or stop the engine as follows.

### ▽ Before starting the engine

Before using the remote engine start system to start the engine, confirm the following conditions.

- The select lever is in the “P” position.
- All doors are closed.
- The engine hood is closed.
- The push-button ignition switch is in the “OFF” position.

### ▽ Starting the engine

1. Press the lock button briefly. The hazard warning flashers then flash once.
2. Within 2 seconds, press the lock button briefly again. The hazard warning flashers then flash once again.
3. After step 2, immediately press and hold the lock button. The hazard warning flashers then flash once.
4. Approximately 3 seconds after step 3, release the lock button. The engine will then start successfully.

### ▽ Stopping the engine

Press and hold the lock button to stop the engine with remote engine start system.

### ▽ Automatic engine shutdown

The remote engine start system will automatically shut down or will not start the engine under the following conditions.

- The total run-time has exceeded 20 minutes.
- Any door is opened.
- The select lever is moved to any position other than “P”.
- The engine hood is opened.
- The push-button ignition switch is pressed.
- The brake pedal is depressed.

- The engine speed is 3,000 rpm or more.

The time setting until the engine automatically stops can be changed. To change it, please contact your SUBARU dealer. Note that some settings may violate state, provincial, or local laws and regulations. Check the laws in your area to determine which setting is permitted.

### ▼ Entering the vehicle while it is running via remote start

1. Unlock the vehicle doors using the keyless access function. If you unlock the vehicle's doors manually using the key, the vehicle's alarm system will trigger (if the alarm system is armed prior to activating the remote engine start system) and the engine will turn off. Perform either of the following procedures to disarm the alarm system. Refer to "Alarm system" 2-24.

- Switch the ignition to the "ACC" or "ON" state by pressing the push-button ignition switch once or twice, respectively.
  - Press any button on the access key fob/transmitter.
2. Enter the vehicle.
3. The engine will shut down when any door is opened.
4. Press the push-button ignition switch while depressing the brake pedal to restart

the engine.

### ▼ Entering the vehicle following remote engine start shutdown

An alarm trigger may occur if the vehicle is opened by the remote keyless entry transmitter within a few seconds immediately following remote engine start shutdown.

### ▼ Pre-heating or pre-cooling the interior of the vehicle

Before exiting the vehicle, set the temperature controls to the desired setting and operation. After the system starts the engine, the heater or air conditioning will activate and heat or cool the interior to your setting.

### ▼ System maintenance

Perform the procedure described in "Replacing battery of access key fob" 11-52.

## Manual transmission

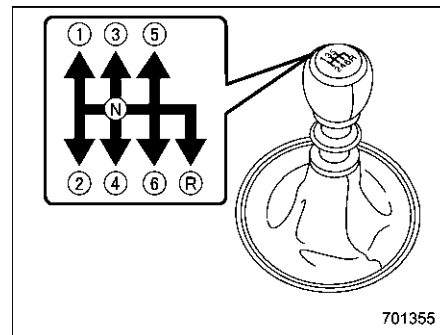

This manual transmission is a completely synchromesh, 6-forward-speed and 1-reverse-speed transmission.

The shift pattern is shown on the shift lever knob.

To change the shift lever position:

1. Depress the clutch pedal.
2. To shift into all positions other than "R", move the shift lever accordingly.

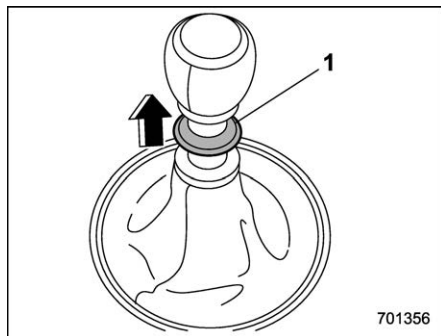

1) Slider

3. To shift into the “R” position, hold up the slider, move the lever to the “R” position, then release the slider.

4. Gradually release the clutch pedal.

If it is difficult to shift into gear, put the transmission in neutral, release the clutch pedal momentarily, and then try again.

### ⚠ WARNING

- Do not drive the vehicle with the clutch disengaged (i.e., when the clutch pedal is depressed) or with the shift lever in the neutral position. Engine braking has no effect in either of these conditions and the risk of an accident is consequently increased.
- Do not engage the clutch (i.e., release the clutch pedal) suddenly when starting the vehicle. By doing so the vehicle might unexpectedly accelerate or the transmission could malfunction.

### ⚠ CAUTION

Shift into reverse **ONLY** when the vehicle has completely stopped. It may cause damage to the transmission to try shifting into reverse when the vehicle is moving.

## ■ Shifting speeds

### ▼ Recommended shifting speeds

The best compromise between fuel economy and vehicle performance during normal driving is ensured by shifting up at the speeds listed in the following table.

Shift up	mph (km/h)
1st to 2nd	15 (24)
2nd to 3rd	25 (40)
3rd to 4th	40 (64)
4th to 5th	45 (72)
5th to 6th	50 (80)

### ▼ Shift-up indicator (STI)

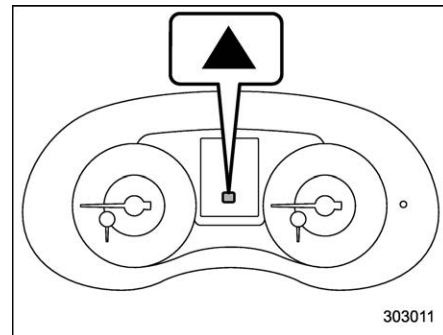

The shift-up indicator appears to inform

the driver about the upshift timing.

The shift-up indicator can be activated or deactivated. For details, refer to “Gear position indicator (MT models)/Shift-up indicator (STI)” 3-34.

**▼ Maximum allowable speeds**

The following table shows the maximum speeds that are possible with each different gear. The tachometer’s needle will enter the red area if these speeds are exceeded.

With the exception of cases where sudden acceleration is required, do not drive the vehicle with the tachometer’s needle inside the red area. Failure to observe this precaution can lead to excessive engine wear and poor fuel economy.

Gear	STI mph (km/h)	Except STI mph (km/h)
1st	31 (50)	30 (49)
2nd	51 (82)	55 (88)



**WARNING**

**When shifting down a gear, ensure that the vehicle is not travelling at a speed exceeding the Maximum Allowable Speed for the gear which is about to be selected. Failure to observe this precaution can lead to**

**engine over-revving and this in turn can result in engine damage.**  
**In addition, sudden application of engine brakes when the vehicle is travelling on a slippery surface can lead to wheel locking; as a consequence, control of the vehicle may be lost and the risk of an accident increased.**

**NOTE**

**Never exceed the posted speed limit.**

**■ Driving tips**

**NOTE**

**If the accelerator and brake pedals are depressed at the same time, driving torque may be restrained. This is not a malfunction.**

Do not drive with your foot resting on the clutch pedal and do not use the clutch to hold your vehicle at a standstill on an upgrade. Either of those actions may cause clutch damage.

Do not drive with your hand resting on the shift lever. This may cause wear on the transmission components.

When it is necessary to reduce vehicle speed due to slow traffic, turning corners, or driving up steep hills, downshift to a

lower gear before the engine starts to labor.

On steep downgrades, downshift the transmission to 5th, 4th, 3rd or 2nd gear as necessary; this helps to maintain a safe speed and to extend brake pad life.

In this way, the engine provides a braking effect. Remember, if you “ride” (over use) the brakes while descending a hill, they may overheat and not work properly.

The engine may, on rare occasions, knock when the vehicle rapidly accelerates or rapidly pulls away from a standstill. This phenomenon is not an indication of a problem in your vehicle.

## Driver's Control Center Differential (C.DIFF/DCCD) (STI)

### WARNING

Always use the utmost care when driving. Being overconfident because you are driving a vehicle with a driver's control center differential could easily lead to a serious accident.

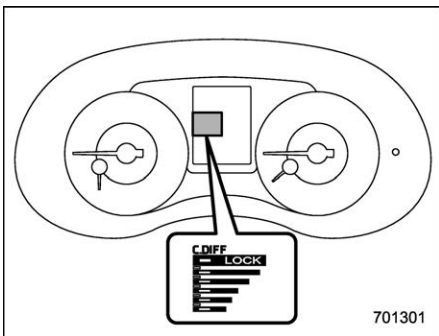

### CAUTION

- All the indicators will flash in the event that the driver's control center differential has a malfunction.

tion. Have the vehicle inspected by your SUBARU dealer.

- If a malfunction occurs in the vehicle (for example, when the rear differential oil temperature warning light illuminates), all of the indicators may disappear and the setting value for the initial limited slip differential (LSD) torque of the driver's control center differential (C.DIFF/DCCD) may be cancelled. However, it does not indicate a malfunction of the C.DIFF/DCCD itself.

The driver's control center differential allows you to freely change the degree of limitation of the differential action (limited slip differential (LSD) torque) of your vehicle's center differential.

By using the center differential control switch, you can set an initial LSD torque to match the road surface conditions, driving conditions and your driving style.

The driver's control center differential has the following modes.

- Auto mode: the system automatically adjusts the initial LSD torque.
- Manual mode: you can change to the desired mode manually by using the center differential control switch.

## NOTE

If you rapidly depress and release the accelerator pedal while driving at low speed, you may hear a knocking sound from the vicinity of the center differential and rear differential. This sound occurs because of the structure of the center differential. It does not indicate a problem.

### ■ To change mode of driver's control center differential

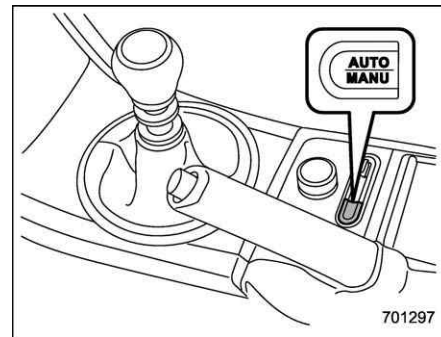

Press the "AUTO-MANU" switch on the center console to switch from auto mode to manual mode or vice versa. When you select the auto mode, the "AUTO" indicator appears. When you select the manual mode, the "AUTO" indicator disappears.

## ■ Auto mode

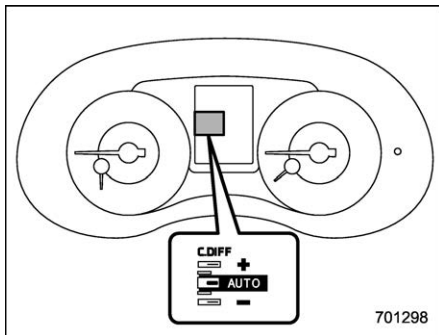

In the auto mode, the system estimates the driving and road conditions using signals from the wheel speed sensor, throttle position sensor, steering angle sensor and brake switch, etc. According to the result, it electronically and automatically controls the degree of limitation of the differential action (LSD torque) to optimize the differential action of the center differential. When you turn the ignition switch ON, the "AUTO" indicator on the combination meter appears.

The auto mode has 3 modes as follows.

Mode	Operation
AUTO [+]	This mode emphasizes traction control and strengthens the limitation of differential action that is suitable for driving on slippery roads for vehicle stability.
AUTO	This mode is suitable for most driving situations.
AUTO [-]	This mode is suitable when you seek quick response from the steering wheel and smooth driving.

## ▼ Mode setting method

In most situations, it is recommended that the "AUTO" mode is selected.

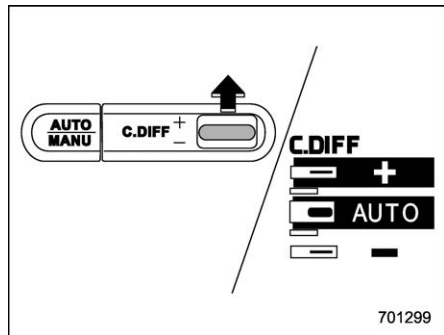

Push the control switch forward to select the "AUTO [+]" mode. After setting the

mode, "AUTO [+]" appears.

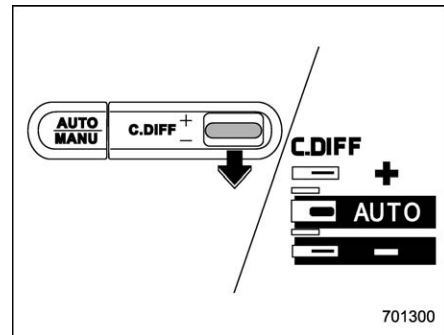

Pull the control switch rearward to select the "AUTO [-]" mode. After setting the mode, "AUTO [-]" appears.

When the "AUTO [+]" mode is selected, pull the control switch rearward to change to the "AUTO" mode. When the "AUTO [-]" mode is set, push the control switch forward to change to the "AUTO" mode.

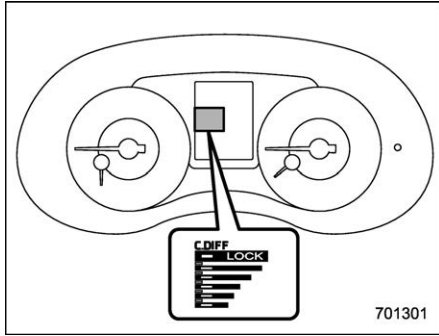
**Manual mode**

701301

In the manual mode, you can use the center differential control switch to adjust the initial LSD torque as desired. When this mode is selected, the “AUTO” indicator disappears.

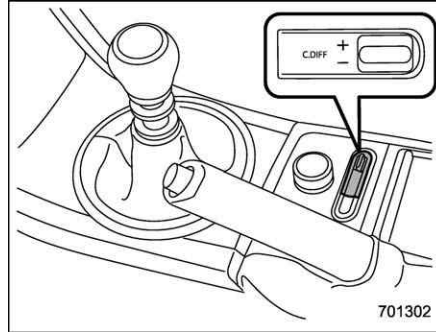
**Center differential control switch and indicator**

701302

The control switch is located beside the parking brake lever. Push the control switch forward or pull it rearward to change the initial LSD torque.

The center differential indicator on the combination meter gives six levels of indication. The indicator and control switch are linked; when operating the switch to change the initial LSD torque, the indicator changes accordingly.

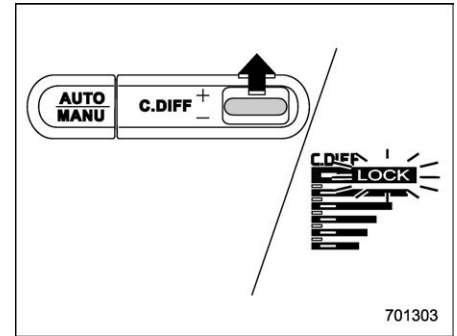

701303

Push the switch forward to increase the initial LSD torque; when the “LOCK” indicator appears, the initial LSD torque setting is maximum. The center differential will then be almost completely locked.

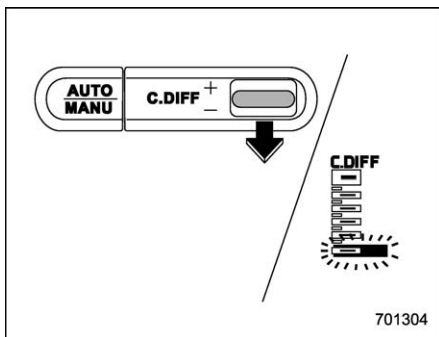

Pull the switch rearward to reduce the initial LSD torque. When the lowest position of the driver's control center differential indicator is displayed, the initial LSD torque will be minimum.

**CAUTION**

- Do not operate the control switch when a wheel slippage occurs. Wait until the wheelspin has been brought under control.
- Under any of the following conditions after setting to the manual mode, pull the center differential control switch to minimize the initial LSD torque:
  - When a temporary spare tire is installed

- When your vehicle is towed
- When the vehicle is stopped with the manual mode selected

**NOTE**

- A higher initial LSD torque setting gives the vehicle greater traction when driving straight ahead but makes cornering more difficult. Remember this when adjusting the initial LSD torque. In general, higher initial LSD torque settings assist driving on slippery roads and lower settings for non-slippery roads. When the vehicle is stuck in snow or mud, setting the initial LSD torque to the maximum will help to free the vehicle.
- The setting of the initial LSD torque will remain even when the auto mode is selected or the ignition switch is turned to the "LOCK"/"OFF" position. However, the initial LSD torque will be minimized when the battery is disconnected and reconnected.
- During cornering or when making turns (especially when going into the garage), the rotational difference between the front and rear wheels may cause a braking effect accompanied by vibration and noise. This does not

indicate a problem. The phenomenon will disappear when setting the initial LSD torque to the minimum.

In the auto mode, it controls the initial LSD torque automatically. While in the auto mode, this phenomenon sometimes occurs depending on the driving condition, however, it does not indicate a problem.

- Use the center differential indicator only as a rough indication of the initial LSD torque.
- If you operate the center differential control switch while quickly accelerating or turning a tight corner, you may feel slight shocks. This is due to differential action by the center differential and does not indicate a problem.

**Temporary release**

When the driver stops the vehicle and pulls the parking brake lever after manually setting the initial LSD torque, the LSD torque is temporarily minimized. However, the indicator on the combination meter continues to show the driver's selected initial LSD torque. When the driver releases the parking brake lever, the initial LSD torque set by the driver is restored.



## Continuously variable transmission

The continuously variable transmission is electronically controlled and provides an infinite number of forward speeds and 1 reverse speed. It also has a manual mode.



### WARNING

Do not shift from the “P” or “N” position into the “D” or “R” position while depressing the accelerator pedal. This may cause the vehicle to jump forward or backward.



### CAUTION

- Observe the following precautions. Otherwise, the transmission could be damaged.
  - Shift into the “P” or “R” position only after the vehicle has completely stopped.
  - Do not shift from the “D” position into the “R” position or vice versa until the vehicle has completely stopped.
- Do not race the engine for more than 5 seconds in any position except the “N” or “P” position

when the brake is applied or when chocks are used in the wheels. This may cause the transmission fluid to overheat.

- Never move the vehicle as follows. Doing so may result in an unexpected accident or malfunction.
  - Moving rearward by inertia with the select lever set in a forward driving position.
  - Moving forward by inertia with the select lever set in the “R” position.
- When parking the vehicle, first securely apply the parking brake and then place the select lever in the “P” position. Do not park for a long time with the select lever in any other position as doing so could result in a dead battery.

### NOTE

- When the engine coolant temperature is still low, the transmission will shift at higher engine speeds than when the coolant temperature is sufficiently high in order to shorten the warm-up time and improve driveability. The gearshift timing will automatically

shift to the normal timing after the engine has warmed up.

- Immediately after transmission fluid is replaced, you may feel that the transmission operation is somewhat unusual. This results from invalidation of data which the on-board computer has collected and stored in memory to allow the transmission to shift at the most appropriate times for the current condition of your vehicle. Optimized shifting will be restored as the vehicle continues to be driven for a while.
  - When driving under continuous heavy load conditions such as when climbing a long, steep hill, the engine speed or the vehicle speed may automatically be reduced. This is not a malfunction. This phenomenon results from the engine control function maintaining the cooling performance of the vehicle. The engine and vehicle speed will return to a normal speed when the engine is able to maintain the optimum cooling performance after the heavy load decreases. Take extremely care when driving under a heavy load.
  - The continuously variable transmission is a chain type system that provides superior transmission efficiency for maximum fuel economy. At times, depending on varying driving conditions, a chain operating noise may be

heard that is characteristic of this type of system.

### ■ Select lever

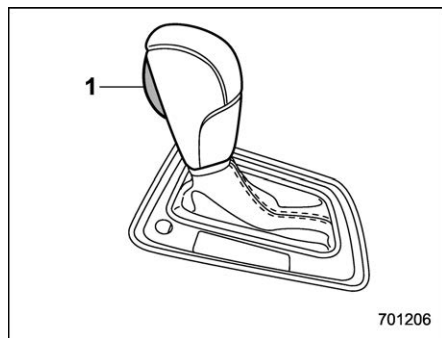

1) Select lever button

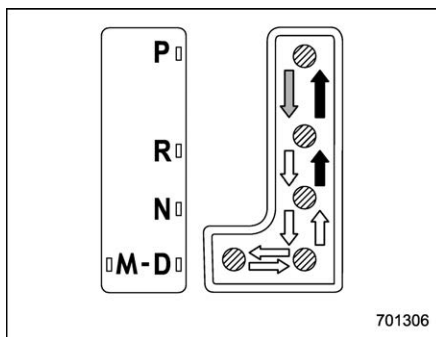

- ➡ : With the brake pedal depressed, shift while pressing the select lever button in.
- ➡ : Shift while pressing the select lever button in.
- ↔ : Shift without pressing the select lever button.

The select lever has four positions, “P”, “R”, “N”, “D” and it also has an “M” position for using the manual mode.

### NOTE

**For some models, to protect the engine while the select lever is in the “P” or “N” position, the engine is controlled so that the engine speed may not become too high even if the accelerator pedal is depressed hard.**

### ▼ P (Park)

This position is for parking the vehicle and starting the engine. In this position, the transmission is mechanically locked to prevent the vehicle from rolling freely.

When you park the vehicle, first apply the parking brake firmly, then shift into the “P” position. Do not hold the vehicle with only the mechanical friction of the transmission.

To shift the select lever from the “P” position to any other position, you should depress the brake pedal fully then move the select lever. This prevents the vehicle from lurching when it is started.

### ▼ R (Reverse)

This position is for backing the vehicle. To shift from the “N” to “R” position, stop the vehicle completely then move the lever to the “R” position while pressing the select lever button in.

Even when you have turned the ignition switch to the “ACC” position, you can still move the select lever from the “N” to “R” position by depressing the brake pedal. For details, refer to “Shift lock function” 7-26.

### ▼ N (Neutral)

This position is for restarting a stalled engine. In this position, the transmission is neutral, meaning that the wheels and transmission are not locked. Therefore, the vehicle will roll freely, even on the slightest incline unless the parking brake or foot brake is applied.



### WARNING

**Do not drive the vehicle with the select lever in the “N” (neutral) position. Engine braking has no effect in this condition and the risk of an accident is consequently increased.**

### ▼ D (Drive)

This position is for normal driving. The transmission shifts automatically and continuously into a suitable gear according to the vehicle speed and the acceleration you require. Also, while driving up and down a hill, the transmission assists and controls the driving performance and engine braking while corresponding to the road grade.

When more acceleration is required in the “D” position, depress the accelerator pedal fully to the floor and hold that position. The transmission will automatically downshift.

If you operate one of the shift paddles behind the steering wheel while driving in the “D” position, the transmission will temporarily switch to the manual mode. In this mode, you can shift into any gear position using the shift paddles. For details about the manual mode, refer to “Selection of manual mode” 7-25. Once the vehicle speed stabilizes, the transmission will switch from the manual mode back to the “D” position for normal driving.

### ■ Selection of manual mode

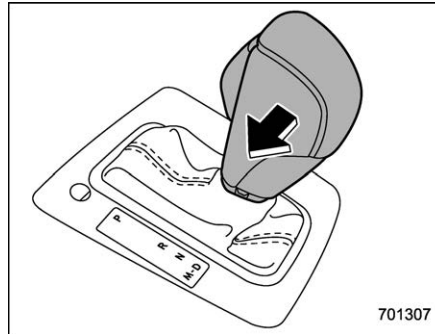

With the vehicle either moving or stationary, move the select lever from the “D” position to the “M” position to select the manual mode.

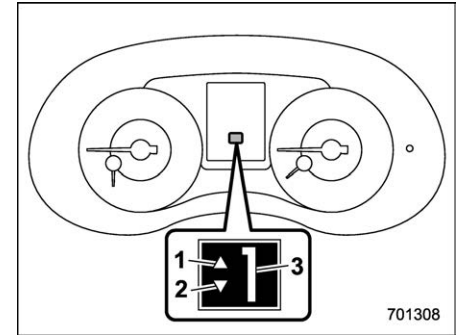

- 1) Upshift indicator
- 2) Downshift indicator
- 3) Gear position indicator

When the manual mode is selected, the gear position indicator and upshift indicator and/or downshift indicator on the combination meter appear.

The gear position indicator shows the currently selected gear in the following range.

- 1st-to-8th-gear range (when the Sport Sharp (S#) mode is selected)
- 1st-to-6th-gear range (in other situations)

The upshift and downshift indicators show when a gear shift is possible. When the upshift indicator “▲” appears, upshifting is possible. When the downshift indicator

“▼” appears, downshifting is possible. When both indicators appear, upshifting and downshifting are both possible. When the vehicle stops (for example, at traffic signals), the downshift indicator turns off.

Gearshifts can be performed using the shift paddle behind the steering wheel.

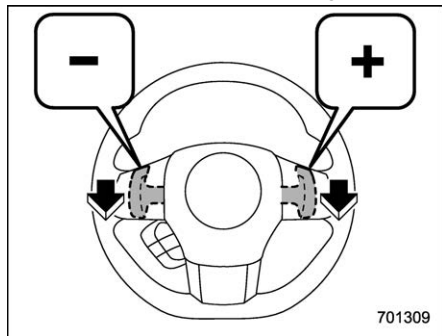

To upshift to the next higher gear position, pull the shift paddle that has “+” indicated on it. To downshift to the next lower gear position, pull the shift paddle that has “-” indicated on it.

To deselect the manual mode, return the select lever to the “D” position from the “M” position.

While driving with the select lever in the “D” position, if you change gears by operating the shift paddle, the gear position indicator

light illuminates and shows the current gear condition.

### CAUTION

Do not place or hang anything on the shift paddles. Doing so may result in accidental gear shifting.

### NOTE

Please read the following points carefully and bear them in mind when using the manual mode.

- If you attempt to shift down when the engine speed is too high, i.e., when a downshift would push the tachometer needle beyond the red zone, beeps will be emitted to warn you that the downshift is not possible.
- If you attempt to shift up when the vehicle speed is too low, the transmission will not respond.
- You can perform a skip-shift (for example, from 4th to 2nd) by operating the shift paddle twice in rapid succession.
- The transmission automatically selects 1st gear when the vehicle stops moving.
- If the temperature of the transmission fluid becomes too high, the “AT OIL TEMP” warning light on the combi-

nation meter will illuminate. Immediately stop the vehicle in a safe location and let the engine idle until the warning light turns off.

- By selecting the Sport Sharp (S#) mode, upshifting will not occur automatically. According to the road conditions, shift change manually so that the tachometer needle does not enter the red zone. Also, if the engine revolutions reach the specified number, the fuel supply will be cut. In this case, perform shift up operation.

### ▼ To deselect the manual mode

To deselect the manual mode, return the select lever to the “D” position from the “M” position.

### ■ Shift lock function

The shift lock function helps prevent the improper operation of the select lever.

- You cannot move the select lever with the ignition switch in the “ON” position and the brake pedal depressed.
- You cannot move the select lever from the “P” position to any other position unless the brake pedal is depressed. Depress the brake pedal first, and then operate the select lever.
- Only the “P” position allows you to turn the ignition switch from the “ACC” position

to the "LOCK"/"OFF" position and remove the key from the ignition switch.

- If you turn the ignition switch to the "ACC" position while the select lever is in the "N" position, the select lever may not be moved to the "P" position without depressing the brake pedal and pressing the select lever button.

### ▼ Shift lock release

If you cannot move the select lever, turn the ignition switch back to the "ON" position then move the select lever to the "P" position with the select lever button pressed and brake pedal depressed.

If the select lever does not move after performing the above procedure, check and confirm the following and release the shift lock accordingly.

- **When you cannot shift the select lever from "P" to "N":**

Refer to "Shift lock release using the shift lock release button" 7-27.

- **When you cannot shift the select lever from "N" to "R", "P":**

Place the ignition switch in the "ACC" position, then move the select lever to the "P" position with the brake pedal depressed.

If the select lever still does not move, refer

to "Shift lock release using the shift lock release button" 7-27.

If the shift lock cannot be released without using the shift lock release button in the above cases, there may be a malfunction in the shift lock system or the vehicle control system.

Contact a SUBARU dealer for an inspection as soon as possible.

### ▼ Shift lock release using the shift lock release button

Perform the following procedure to release the shift lock.

1. Apply the parking brake and stop the engine.

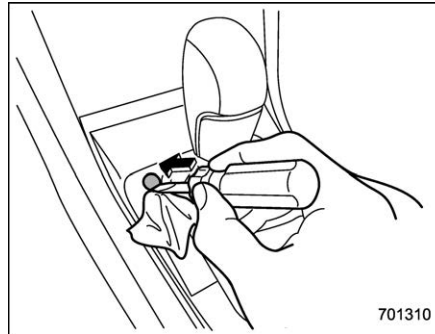

2. Wrap the tip of a flat-head screwdriver with vinyl tape or a cloth and use it to remove the shift lock cover. The shift lock

release button is located under the shift lock cover.

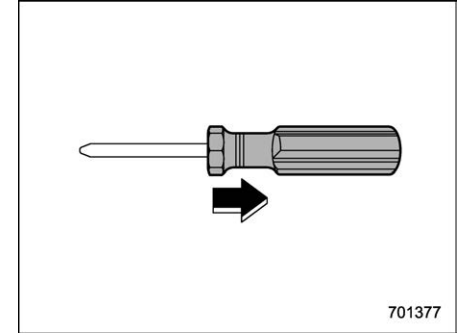

3. Remove the grip portion of the screwdriver.

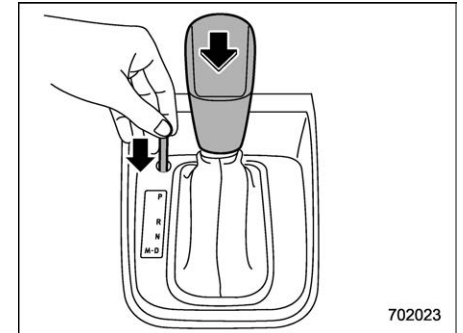

4. While depressing the brake pedal, insert a screwdriver into the hole, press

the shift lock release button using a screwdriver, and then move the select lever.

If the select lever does not move after performing the above procedure, the shift lock system may be malfunctioning. Contact a SUBARU dealer for an inspection as soon as possible.

### ■ Driving tips

#### NOTE

**If the accelerator and brake pedals are depressed at the same time, driving torque may be restrained. This is not a malfunction.**

- Always apply the foot or parking brake when the vehicle is stopped in the “D” or “R” position.
- Make sure to apply the parking brake when parking your vehicle. Do not hold the vehicle with only the mechanical friction of the transmission.
- Do not keep the vehicle in a stationary position on an uphill grade by using the “D” position. Use the brake instead.
- The engine may, on rare occasions, knock when the vehicle rapidly accelerates or rapidly pulls away from a standstill. This phenomenon does not indicate a malfunction.

## SI-DRIVE (if equipped)

SI-DRIVE (SUBARU Intelligent Drive) works to maximize engine performance, control and efficiency.

This system consists of three modes:

- Intelligent (I) mode
- Sport (S) mode
- Sport Sharp (S#) mode

By adjusting the SI-DRIVE selector, the character of the power unit changes.

### ■ Intelligent (I) mode

- ▼ For smooth, efficient performance driving

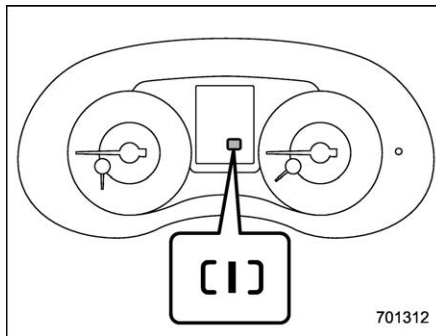

The Intelligent (I) mode provides well-balanced performance with greater fuel

efficiency and smooth driveability without stress. Power delivery is moderate during acceleration for maximum fuel efficiency.

This is ideal for around-town driving and situations that do not require full power output. It provides better control in difficult driving conditions, such as slippery roads or loose surfaces, due to gentler throttle response.

#### STI:

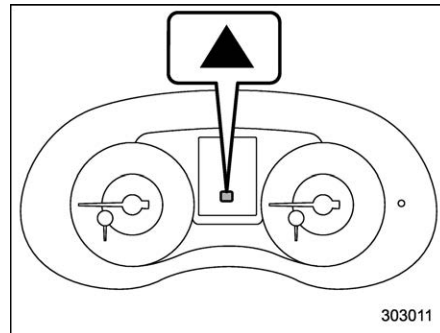

When the Intelligent (I) mode is selected, a shift-up indicator “▲” on the combination meter will blink to signal the best time to shift gears for maximum fuel efficiency.

#### Except STI:

The linear acceleration characteristic of the Intelligent (I) mode is ideal for normal driving.

## ■ Sport (S) mode

### ▼ For all-around performance driving

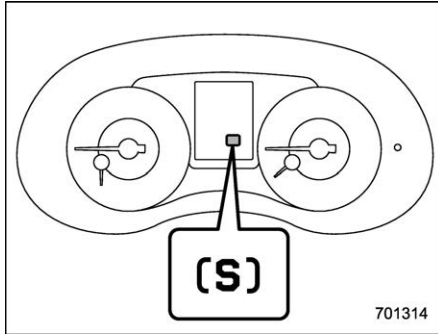

The Sport (S) mode provides the engine power desired by those who want to make the driving experience their own personal adventure.

#### STI:

The linear acceleration characteristic of the Sport (S) mode is ideal for normal driving.

## ■ Sport Sharp (S#) mode

### ▼ For maximum performance driving

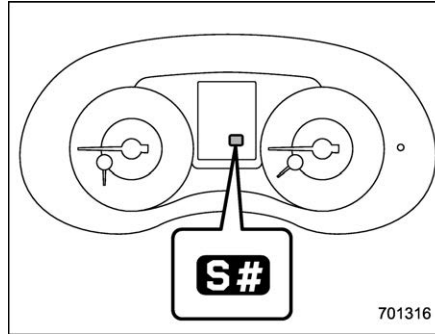

For sports-minded drivers, the Sport Sharp (S#) mode offers an exhilarating level of engine performance and control. The throttle becomes more responsive regardless of the engine speed. Delivering maximum driving enjoyment, this mode is ideal for driving on twisting roads and for merging or overtaking other vehicles on the freeway with confidence.

### ▼ Except STI

When you select the Sport Sharp (S#) mode with the select lever in the “D” position, the transmission gear ratio will shift from variable speed to eight-speed. The select lever/gear position indicator display will change from “D” to the gear position.

When selecting Sport Sharp (S#) mode, the following controls will be applied.

- **Uphill control**

Prevents unnecessary shift-up/shift-down during ascent.

- **Cornering control**

While turning, if there is a large centrifugal force, shift-up will not occur: during re-acceleration.

- **Braking control**

At the beginning of corners etc., heavy application of the brake pedal will cause automatic downshift and gently re-accelerate.

- **Sudden acceleration return control**

During acceleration, if acceleration pedal is returned suddenly (for example, at corners etc.), shift-up will not be applied.

## ■ SI-DRIVE switch

### NOTE

- The next time you turn on the engine, the following SI-DRIVE mode will be selected.

- Intelligent (I) mode if you have turned off the engine in the Intelligent (I) mode
- Sport (S) mode if you have turned off the engine in the Sport (S) mode or Sport Sharp (S#) mode

- If the CHECK ENGINE warning light/malfunction indicator light illuminates during engine operation, the SI-DRIVE mode changes to the Sport (S) mode. In this case, it is not possible to change to the Sport Sharp (S#) mode or Intelligent (I) mode.

- If the engine coolant temperature becomes so high that the engine could overheat, it is not possible to change to the Sport Sharp (S#) mode. While the vehicle is in the Sport Sharp (S#) mode, it changes to the Sport (S) mode when the engine coolant temperature increases.

- If any of the SI-DRIVE indicators blink, the SI-DRIVE system may be malfunctioning. Contact your SUBARU dealer.

### ▼ STI

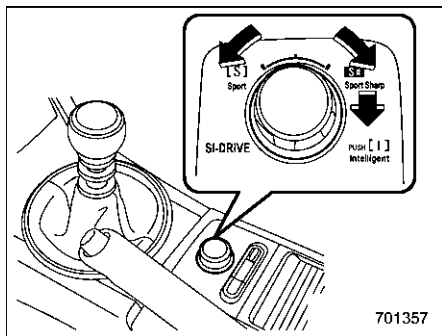

SI-DRIVE switch

**To select the Intelligent (I) mode:**

Push the SI-DRIVE switch.

**To select the Sport (S) mode:**

Rotate the SI-DRIVE switch to the left.

**To select the Sport Sharp (S#) mode:**

Rotate the SI-DRIVE switch to the right.

After operating the SI-DRIVE switch, the switch returns to its original position.

### ▼ Except STI

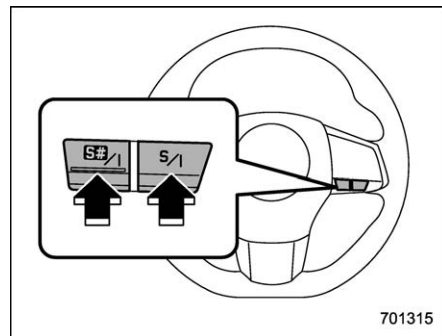

SI-DRIVE switches

**To select the Intelligent (I) mode:**

- Press the "S/I" switch when the Sport (S) mode is selected.
- Press the "S#/I" switch when the Sport Sharp (S#) mode is selected.

**To select the Sport (S) mode:**

Press the "S/I" switch when any mode other than Sport (S) mode is selected.

**To select the Sport Sharp (S#) mode:**

Press the "S#/I" switch when any mode other than Sport Sharp (S#) mode is selected.



## Limited slip differential (LSD) (STI)

The LSD provides optimum distribution of power according to the difference in revolutions between the right and left wheels that may be caused by certain driving conditions, thereby improving driving stability on snow-covered, muddy or other slippery roads or when high speed driving.

### CAUTION

- Never start the engine while a tire on one side is jacked up, as the vehicle may move.
- If one tire is spinning in mud, avoid continued spinning at high speed as this could adversely affect the LSD.
- If you use a temporary spare tire to replace a flat tire, be sure to use the original temporary spare tire stored in the vehicle. Using other sizes will adversely affect the LSD.

## Power steering

### ■ STI

The vehicle is equipped with a hydraulic power steering system. The power steering system operates only when the engine is running.

If you lose power steering assist because the engine stops or the system fails to function, you can steer but it will take much more effort.

### CAUTION

**Do not hold the steering wheel at the fully locked position left or right for more than 5 seconds. This may damage the power steering pump.**

### NOTE

**Right after the engine has been started and before it has warmed up, you may hear a noise coming from areas adjacent to the power steering pump which is located at the right-front area of the engine compartment. This noise is normal. It does not indicate power steering system trouble.**

### ■ Except STI

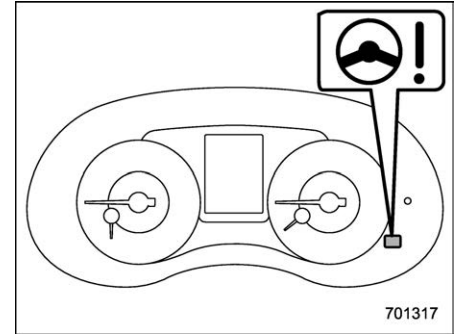

### Power steering warning light

The vehicle is equipped with an electric power steering system. The power steering system operates only while the engine is running. When you turn the ignition switch to the “ON” position, the power steering warning light on the combination meter illuminates to inform the driver that the warning system is functioning properly. Then, if the engine started, the warning light turns off to inform the driver that the steering power assist is operational.



### CAUTION

While the power steering warning light is illuminated, there may be more resistance when the steering wheel is operated. Drive carefully to the nearest SUBARU dealer and have the vehicle inspected immediately.

### NOTE

If you operate the steering wheel in the following ways, the power steering control system may temporarily limit the power assist in order to prevent the system components, such as the control computer and drive motor, from overheating.

- You operate the steering wheel frequently and turn it sharply while the vehicle is maneuvered at extremely low speeds, such as while frequently turning the steering wheel during parallel parking.
- You keep the steering wheel in the fully turned position for a long period of time.

At this time, there will be more resistance when steering. However, this is not a malfunction. Normal steering force will be restored after the steering

wheel is not operated for a while and the power steering control system has an opportunity to cool down. However, if the power steering is operated in a non-standard way which causes power assist limitation to occur too frequently, this may result in a malfunction of the power steering control system.

## Braking

### ■ Braking tips



### WARNING

Never rest your foot on the brake pedal while driving. This can cause dangerous overheating of the brakes and needless wear on the brake pads and linings.

#### ▼ When the brakes get wet

When driving in rain or after washing the vehicle, the brakes may get wet. As a result, brake stopping distance will be longer. To dry the brakes, drive the vehicle at a safe speed while lightly depressing the brake pedal to heat up the brakes.

#### ▼ Use of engine braking

Remember to make use of engine braking in addition to foot braking. When descending a grade, if only the foot brake is used, the brakes may start working improperly because of brake fluid overheating, caused by overheated brake pads. To help prevent this, shift into a lower gear to get stronger engine braking.

#### ▼ Braking when a tire is punctured

Do not depress the brake pedal suddenly when a tire is punctured. This could cause

a loss of control of the vehicle. Keep driving straight ahead while gradually reducing speed. Then slowly pull off the road to a safe place.

## ■ Brake system

### ▼ Two separate circuits

Your vehicle has two separate circuit brake systems. Each circuit works diagonally across the vehicle. If one circuit of the brake system should fail, the other half of the system still works. If one circuit fails, the brake pedal will go down much closer to the floor than usual and you will need to press it down much harder. And a much longer distance will be needed to stop the vehicle.

### ▼ Brake booster

The brake booster uses engine manifold vacuum to assist braking force. Do not turn off the engine while driving because that will turn off the brake booster, resulting in poor braking power.

The brakes will continue to work even when the brake booster completely stops functioning. If this happens, however, you will have to depress the pedal much harder than normal and the braking distance will increase.

### ▼ Brake assist system

#### ⚠ WARNING

**Do not be overconfident about the brake assist. It is not a system that brings more braking ability to the vehicle beyond its braking capability. Always use the utmost care when driving regarding vehicle speed and safe distance.**

#### ⚠ CAUTION

**When you need to brake suddenly, continue depressing the brake pedal strongly to obtain the effect of the brake assist.**

Brake assist is a driver assistance system. It assists the brake power when the driver cannot depress the brake pedal strongly and the brake power is insufficient. Brake assist generates the brake power according to the speed at which the driver depresses the brake pedal.

## NOTE

When you depress the brake pedal strongly or suddenly, the following phenomena occur. However, even though these occur, they do not indicate any malfunctions, and the brake assist system is operating properly.

- You might feel that the brake pedal is applied by lighter force and generates a greater braking force.
- You might hear an ABS operating noise from the engine compartment.

## ■ Disc brake pad wear warning indicators

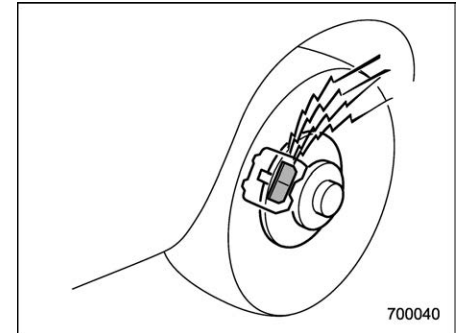

The disc brake pad wear warning indicators on the disc brakes give a warning noise when the brake pads are worn.

If a squeaking or scraping noise is heard from the disc brakes while braking, immediately have your vehicle checked by your SUBARU dealer.

### ■ High performance brake system (Brembo equipped models)

Your vehicle is equipped with a high performance brake system that provides optimum braking force under various driving conditions. The brake system has the following characteristics.

#### Brake noises

The brake pads are made of iron-based material. Therefore, unusual noise may be heard when depressing the brake pedal slightly before stopping completely. However, this does not indicate a malfunction.

#### Discoloration

Frequent severe driving, such as repeated driving on sharp uphill or downhill grades, can cause discoloration of the paint on the brake calipers. The discoloration will not affect the braking performance.

#### Stuck brake pads

- If the vehicle is left parked for an extended period of time with the brake system wet, the iron in the brake pads may form rust and cause the brake pads and

disc rotors to stick together. This may result in noise or vibration while driving. If this occurs, fully depress the brake pedal several times to free the brake pads.

- If the vehicle is left parked for an extended period of time in a cold temperature, the brake pads and disc rotors may be frozen and stuck together. In this case, it may be difficult to start the vehicle.

#### Brake dust

Due to the material used for the brake pads, the wheels may become covered in brake dust. This is not a malfunction, and will not affect the brake performance.

## ABS (Anti-lock Brake System)

The ABS prevents the lock-up of wheels which may occur during sudden braking or braking on slippery road surfaces. This helps prevent the loss of steering control and directional stability caused by wheel lock-up.

When the ABS is operating, you may hear a chattering noise or feel a slight vibration in the brake pedal. This is normal when the ABS operates.

The ABS will not operate when the vehicle speed is below approximately 6 mph (10 km/h).



### WARNING

**Always use the utmost care in driving – overconfidence because you are driving a vehicle with the ABS could easily lead to a serious accident.**

**CAUTION**

- The ABS does not always decrease stopping distance. You should always maintain a safe following distance from other vehicles.
- When driving on badly surfaced roads, gravel roads, icy roads, or over newly fallen snow, stopping distances may be longer for a vehicle with the ABS than one without. When driving under these conditions, therefore, reduce your speed and leave ample distance from other vehicles.
- When you feel the ABS operating, you should maintain constant brake pedal pressure. Do not pump the brake pedal since doing so may defeat the operation of the ABS system.

**■ ABS self-check**

Just after the vehicle is started, you may feel on the brake pedal a vibration similar to when the ABS operates, and you may also hear the sound of the ABS working from the engine compartment. This is caused by an automatic functional test of the ABS being carried out and does not indicate any abnormal condition.

**■ ABS warning light**

Refer to “ABS warning light” 3-20.

**Electronic Brake Force Distribution (EBD) system**

The EBD system maximizes the effectiveness of the brakes by allowing the rear brakes to supply a greater proportion of the braking force. It functions by adjusting the distribution of braking force to the rear wheels in accordance with the vehicle's loading condition and speed.

The EBD system is an integral part of the ABS and uses some of the ABS components to perform its function of optimizing the distribution of braking force. If any of the ABS components used by the EBD system malfunction, the EBD system also stops working.

When the EBD system is operating, you may hear a chattering noise or feel a slight vibration in the brake pedal. This is normal and does not indicate a malfunction.

## ■ Steps to take if EBD system malfunctions

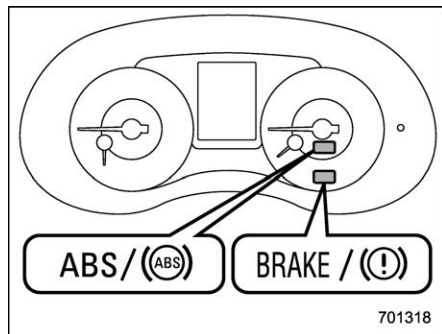

### Brake and ABS warning light

If a malfunction occurs in the EBD system, the system stops working and the brake system warning light and ABS warning light illuminate simultaneously.

The EBD system may be malfunctioning if the brake system warning light and ABS warning light illuminate simultaneously while driving.

Even if the EBD system malfunctions, the conventional braking system will still function. However, the rear wheels will be more prone to locking when the brakes are applied harder than usual and the vehicle's motion may therefore become somewhat harder to control.

If the brake system warning light and ABS warning light illuminate simultaneously, take the following steps.

1. Stop the vehicle in the nearest safe, flat location.
2. Apply the parking brake and turn off the engine.
3. Restart the engine.
4. Release the parking brake.

### Even if both warning lights turn off:

The EBD system may be malfunctioning. Drive carefully to the nearest SUBARU dealer and have the system inspected.

### If both warning lights illuminate again and remain illuminated after restarting the engine:

1. Turn off the engine again.
2. Apply the parking brake.
3. Check the brake fluid level. For details about checking the brake fluid level, refer to "Checking the fluid level" 11-23.

- If the brake fluid level is not below the "MIN" mark, the EBD system may be malfunctioning. Drive carefully to the nearest SUBARU dealer and have the system inspected.

- If the brake fluid level is below the "MIN" mark, DO NOT drive the vehicle. Instead, have the vehicle towed to the nearest

SUBARU dealer for repair.

### WARNING

- **Driving with the brake system warning light illuminated is dangerous. This indicates your brake system may not be working properly. If the light remains illuminated, have the brakes inspected by a SUBARU dealer immediately.**
- **If at all in doubt about whether the brakes are operating properly, do not drive the vehicle. Have your vehicle towed to the nearest SUBARU dealer for repair.**

## Vehicle Dynamics Control system

### WARNING

Always use the utmost care in driving – overconfidence because you are driving a vehicle with the Vehicle Dynamics Control system could easily lead to a serious accident.

### CAUTION

- Even if your vehicle is equipped with Vehicle Dynamics Control system, winter tires should be used when driving on snow-covered or icy roads; in addition, vehicle speed should be reduced considerably. Simply having a Vehicle Dynamics Control system does not guarantee that the vehicle will be able to avoid accidents in any situation.
- Activation of the Vehicle Dynamics Control system is an indication that the road being travelled on has a slippery surface; since having Vehicle Dynamics Control is no guarantee

that full vehicle control will be maintained at all times and under all conditions, its activation should be seen as a sign that the speed of the vehicle should be reduced considerably.

- Whenever suspension components, steering components, or an axle are removed from a vehicle, have an inspection of that system performed by an authorized SUBARU dealer.
- Observe the following precautions in order to ensure that the Vehicle Dynamics Control system is operating properly:
  - Fit all four wheels with tires of the same size, type, and brand. Furthermore, the amount of wear should be the same for all four tires.
  - Keep the tire pressure at the proper level as shown on the vehicle placard attached to the driver's side door pillar.
  - When replacing a flat tire, use only the specified temporary spare tire. However, even with the specified temporary spare tire, the effectiveness of the Vehicle Dynamics Control

system will be reduced.

- If you use non-matching tires, the Vehicle Dynamics Control system may not operate correctly.
- The Vehicle Dynamics Control system helps prevent unstable vehicle motion such as skidding using control of the brakes and engine power. Do not turn off the Vehicle Dynamics Control system unless it is absolutely necessary. If you must turn off the Vehicle Dynamics Control system, drive very carefully according to the road surface condition.

In the event of wheelspin and/or skidding on a slippery road surface and/or during cornering and/or an evasive maneuver, the Vehicle Dynamics Control system adjusts the engine's output and the wheels' respective braking forces to help maintain traction and directional control.

#### • Traction Control Function

The traction control function is designed to prevent spinning of the driving wheels on slippery road surfaces, thereby helping to maintain traction and directional control. Activation of this function is shown by flashing the Vehicle Dynamics Control operation indicator light.

● **Skid Suppression Function**

The skid suppression function is designed to help maintain directional stability by suppressing the wheels' tendency to slide sideways during steering operations. Activation of this function is shown by flashing of the Vehicle Dynamics Control operation indicator light.

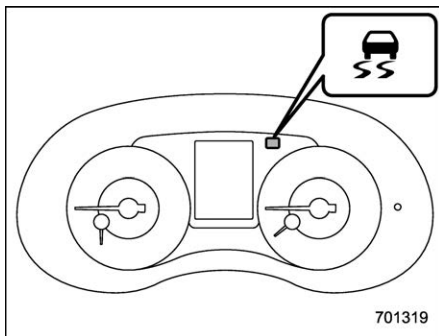

Vehicle Dynamics Control operation indicator light

**NOTE**

- The Vehicle Dynamics Control system may be considered normal when the following conditions occur.
  - Slight twitching of the brake pedal is felt.
  - The vehicle or steering wheel shakes to a small degree.

- An operating sound from the engine compartment is heard briefly when starting the engine and when driving off after starting the engine.
- The brake pedal seems to jolt when driving off after starting the engine.

● In the circumstances shown in the following list, the vehicle may be less stable than it feels to the driver. The Vehicle Dynamics Control System may therefore operate. Such operation does not indicate a system malfunction.

- On gravel-covered or rutted roads
- On unfinished roads
- The vehicle is fitted with snow tires or winter tires.

● Activation of the Vehicle Dynamics Control system will cause operation of the steering wheel to feel slightly different compared to that for normal conditions.

- It is always important to reduce speed when approaching a corner, even if your vehicle is equipped with the Vehicle Dynamics Control system.
- Always turn off the engine before replacing a tire. Failure to do so may render the Vehicle Dynamics Control system unable to operate correctly.

■ **Vehicle Dynamics Control system monitor**

Refer to “Vehicle Dynamics Control warning light/Vehicle Dynamics Control operation indicator light” ¶3-26 and “Vehicle Dynamics Control OFF indicator light/Traction mode indicator light” ¶3-27.

■ **Vehicle Dynamics Control OFF switch**

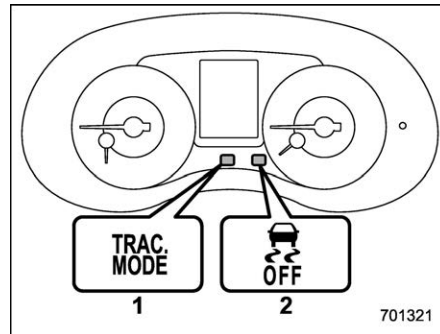

- 1) Traction mode indicator light
- 2) Vehicle Dynamics Control OFF indicator light



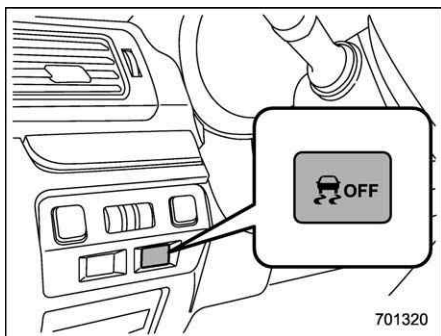

#### Vehicle Dynamics Control OFF switch

When you press the switch briefly or for more than approximately 2 seconds during engine operation, the mode of the Vehicle Dynamics Control system will be changed.

#### ▼ Vehicle Dynamics Control mode

When the ignition switch is on, this mode is selected first.

This mode enables all controls for ABS, the Traction Control System, and the Vehicle Dynamics Control system. Select this mode for most driving situations.

When this mode is selected, both indicator lights on the combination meter turn off.

#### ▼ Traction mode

This mode restricts the functions of the Traction Control System and Vehicle Dynamics Control system and thus delays utilizing their functions as a reaction to vehicle behavior in comparison with the Vehicle Dynamics Control mode. Use this mode in driving situations where the vehicle dynamic performance will improve without decreasing engine torque control.

When you press the switch briefly during engine operation, the traction mode indicator light and the Vehicle Dynamics Control OFF indicator light on the combination meter illuminate. When you press the switch again to reactivate the Vehicle Dynamics Control system, the traction mode indicator light and the Vehicle Dynamics Control OFF indicator light turn off.

#### ▼ Vehicle Dynamics Control OFF mode

This mode allows only the ABS control.

When you press the switch for more than approximately 2 seconds during engine operation, the Vehicle Dynamics Control OFF indicator light on the combination meter illuminates. When you press the switch again to reactivate the Vehicle Dynamics Control system, the Vehicle Dynamics Control OFF indicator light turns

off.

Creating an adequate driving wheel slip by deactivating the Vehicle Dynamics Control system temporarily may help to escape from the following situations. Use the Vehicle Dynamics Control OFF mode as necessary.

- A standing start on a steeply sloping road with a snowy, gravel-covered, or otherwise slippery surface.
- Extrication of the vehicle when its wheels are stuck in mud or deep snow.

You should not deactivate the Vehicle Dynamics Control system except under the above-mentioned situations.

#### NOTE

- If you turn the ignition switch to the “LOCK”/“OFF” position with the Vehicle Dynamics Control system deactivated, the system will be automatically reactivated the next time the engine is started.
- If you press and hold the switch for 30 seconds or longer, the Vehicle Dynamics Control OFF indicator light turns off, the Vehicle Dynamics Control system is activated, and the system ignores any further pressing of the switch. To make the switch usable again, turn the ignition switch to the

“LOCK”/“OFF” position and restart the engine.

- When the Vehicle Dynamics Control OFF mode is selected, the vehicle’s running performance is comparable with that of a vehicle that does not have a Vehicle Dynamics Control system. Do not deactivate the Vehicle Dynamics Control system except when absolutely necessary.

- Even when the Vehicle Dynamics Control OFF mode is selected, components of the brake control system may still activate. When the brake control system is activated, the Vehicle Dynamics Control operation indicator light flashes.

## Tire pressure monitoring system (TPMS) (U.S.-spec. models)

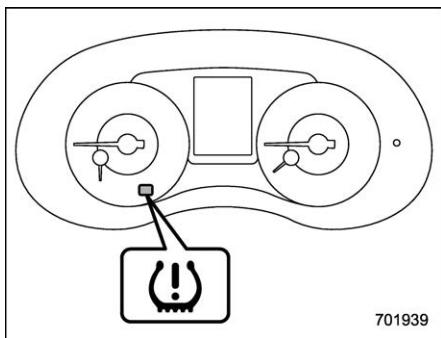

**Low tire pressure warning light**

The tire pressure monitoring system provides the driver with a warning message by sending a signal from a sensor that is installed in each wheel when tire pressure is severely low.

The tire pressure monitoring system will activate only when the vehicle is driven at speeds above 20 mph (32 km/h). Also, this system may not react immediately to a sudden drop in tire pressure (for example, a blow-out caused by running over a sharp object).



## WARNING

- If the low tire pressure warning light illuminates while driving, never brake suddenly. Instead, perform the following procedure. Otherwise, an accident involving serious vehicle damage and serious personal injury could occur.

- (1) Keep driving straight ahead while gradually reducing speed.
- (2) Slowly pull off the road to a safe place.
- (3) Check the pressure for all four tires and adjust the pressure to the COLD tire pressure shown on the tire inflation pressure label on the door pillar on the driver’s side.

Even when the vehicle is driven a very short distance, the tires get warm and their pressures increase accordingly. Be sure to let the tires cool thoroughly before adjusting their pressures to the standard values shown on the tire inflation pressure label. Refer to “Tires and wheels” 11-29. The tire pressure monitoring system does not function when the

vehicle is stationary. After adjusting the tire pressures, increase the vehicle speed to at least 20 mph (32 km/h) to start the TPMS rechecking of the tire inflation pressures. If the tire pressures are now above the severe low pressure threshold, the low tire pressure warning light should turn off a few minutes later.

If this light still illuminates while driving after adjusting the tire pressure, a tire may have significant damage and a fast leak that causes the tire to lose air rapidly. If you have a flat tire, refer to “Flat tires” 9-4.

- When a spare tire is mounted or a wheel rim is replaced without the original pressure sensor/transmitter being transferred, the low tire pressure warning light will illuminate steadily after blinking for approximately one minute. This indicates the TPMS is unable to monitor all four road wheels. Contact your SUBARU dealer as soon as possible for tire and sensor replacement and/or system resetting.
- When a tire is repaired with liquid sealant, the tire pressure warning

valve and transmitter may not operate properly. If a liquid sealant is used, contact your nearest SUBARU dealer or other qualified service shop as soon as possible. Make sure to replace the tire pressure warning valve and transmitter when replacing the tire. You may reuse the wheel if there is no damage to it and if the sealant residue is properly cleaned off. Do not inject any tire liquid or aerosol tire sealant into the tires, as this may cause a malfunction of the tire pressure sensors. If the light illuminates steadily after blinking for approximately one minute, promptly contact a SUBARU dealer to have the system inspected.



#### CAUTION

Do not place metal film or any metal parts in the trunk. This may cause poor reception of the signals from the tire pressure sensors, and the tire pressure monitoring system will not function properly.

#### NOTE

This device complies with part 15 of the FCC Rules. Operation is subject to the following two conditions: (1) This device may not cause harmful interference, and (2) this device must accept any interference received, including interference that may cause undesired operation.

#### FCC CAUTION

Changes or modifications not expressly approved by the party responsible for compliance could void the user's authority to operate the equipment.

## Parking your vehicle

### ⚠ WARNING

- Never leave unattended children or pets in the vehicle. They could accidentally injure themselves or others through inadvertent operation of the vehicle. Also, on hot or sunny days, the temperature in a closed vehicle could quickly become high enough to cause severe or possibly fatal injuries to them.
- Do not park the vehicle over flammable materials such as dry grass, waste paper or rags, as they may burn easily if they come near hot engine or exhaust system parts.
- Be sure to stop the engine if you take a nap in the vehicle. If engine exhaust gas enters the passenger compartment, occupants in the vehicle could die from carbon monoxide (CO) contained in the exhaust gas.

### ■ Parking brake (models without electronic parking brake system)

To set the parking brake, depress the brake pedal firmly and hold it down until the parking brake lever is fully pulled up.

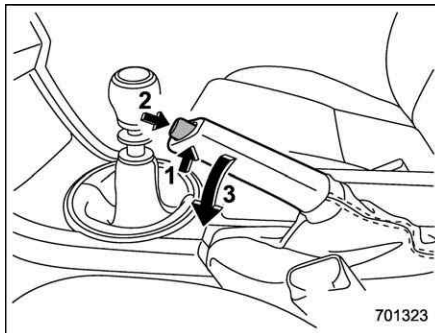

To release the parking brake, perform the following procedure.

1. Pull the lever up slightly.
2. Press the release button.
3. Lower the lever while keeping the button pressed.

When the parking brake is set while the engine is running, the parking brake warning light illuminates. Be sure that the warning light is turned off before driving off. Refer to "Parking brake indicator (models without electronic parking brake system)"

3-21.

### ⚠ CAUTION

Never drive while the parking brake is set because this will cause unnecessary wear on the brake linings. Make sure that the parking brake has been fully released before driving off.

### ■ Electronic parking brake (models with electronic parking brake system)

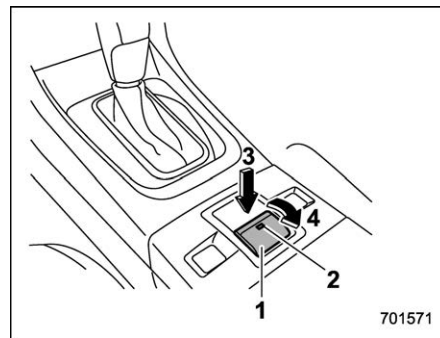

- 1) Parking brake switch
- 2) Indicator light
- 3) Release the electronic parking brake
- 4) Apply the electronic parking brake

**WARNING**

- Before exiting the vehicle, make sure that you turn off the engine. Otherwise, the parking brake may be released and an accident may occur.
- If the brake system warning light turns on, the electronic parking brake system may be malfunctioning. Immediately stop your vehicle in a safe location, use tire stops under the tires to prevent the vehicle from moving and contact your SUBARU dealer.
- If you operate the electronic parking brake when the brake is overheated or the vehicle is on a steep slope, the electronic parking brake indicator light may flash. In this case, the vehicle may start to move and it may lead to an accident. Always use the tire stops.

**CAUTION**

- When the electronic parking brake system has a malfunction and the parking brake cannot be applied, contact your SUBARU

dealer immediately for an inspection. If you have to park your vehicle in such conditions, perform the following procedure.

- Stop your vehicle in a flat location.
- Shift the select lever in the “P” position. When the select lever cannot be shifted into the “P” position, you must release shift lock. Refer to “Shift lock function” 7-26.
- Use tire stops under the tires to prevent the vehicle from moving.
- Never drive with the parking brake applied. Doing so will cause unnecessary wear on the brake pads. Before driving off, always make sure that the parking brake has been released and the brake system warning light has turned off.

Your vehicle is equipped with an electronic parking brake. You can apply/release the parking brake by operating the parking brake switch.

**To apply:** Depress the brake pedal and pull up the parking brake switch.

**To release:** Press the parking brake switch firmly while the ignition switch is in the “ON” position and the brake pedal is depressed.

When the parking brake is applied while the ignition switch is in the “ON” position, the electronic parking brake indicator light and the indicator light on the parking brake switch illuminate. Refer to “Brake system warning light” 3-21.

**NOTE**

- If you press the parking brake switch under the following conditions, the parking brake will not be released.
  - The ignition switch is in the “ACC” or “LOCK”/“OFF” position.
  - You are not depressing the brake pedal.
- The electronic parking brake system uses motors to apply the parking brake. Therefore, operating sounds from the motors will be heard when applying or releasing the parking brake.
- If you operate the parking brake switch under the following conditions, a chirp will sound and the electronic parking brake indicator light will flash.
  - When the electronic parking

brake system has a malfunction.

– When the electronic parking brake operation is prohibited temporarily.

● When you cannot release the parking brake due to, for example, a system malfunction, contact your SUBARU dealer and have your SUBARU dealer release the parking brake.

● If you stop operating the electronic parking brake switch midway or operate extremely slowly, the system may detect an error and turn on the brake system warning light. However, this does not indicate a malfunction if the brake system warning light turns off after operating the switch.

● When the electronic parking brake has not been used for a long period of time, the electronic parking brake may operate automatically after the ignition switch is turned to the “LOCK”/“OFF” position. This occurs due to checking the proper operation of the electronic parking brake and does not indicate a malfunction.

● If you cannot release the electronic parking brake due to the switch malfunction, refer to the instructions described in “Automatic release function by accelerator pedal” 7-44.

After activating the electronic parking

brake, you may hear a short sound several minutes after the electronic parking brake indicator light illuminates as the system confirms proper engagement. This sound is different from the apply and release sound.

This can occur:

- If the brakes are extremely hot.
- If the car is parked on a steep incline.
- If the electronic parking brake is applied after the ignition switch is turned OFF.

This is a normal operating sound under any of these conditions.

#### ▼ Automatic release function by accelerator pedal

The parking brake will be automatically released by depressing the accelerator pedal. However, the automatic release function does not operate under the following conditions.

- Any door (other than the trunk lid) is open.
- The driver’s seatbelt is not fastened.

If the parking brake is automatically released, the electronic parking brake indicator light and the indicator light on the parking brake switch turn off.

#### ▼ Emergency brake



Use the emergency brake only in case of an emergency. If the emergency brake is excessively used, the brake parts will wear down faster or the brake may not work sufficiently due to brake overheating.

#### NOTE

While using the emergency brake:

- The electronic parking brake indicator light and the indicator light on the parking brake switch illuminate and a chirp sounds.
- A sound may be heard from the engine compartment. This is the operating sound of the brake that is activated by the Vehicle Dynamics Control system, and does not indicate a malfunction.

If the foot brake has a malfunction, you can stop the vehicle by pulling the parking brake switch continuously.

While applying the emergency brake, the electronic parking brake indicator light and the indicator light on the parking brake switch illuminate and a chirp sounds.

### ▼ Electronic parking brake system warning

#### ⚠ CAUTION

If the brake system warning light turns on, the electronic parking brake system may be malfunctioning. Immediately stop your vehicle in the nearest safe location and contact your SUBARU dealer.

If a malfunction occurs in the electronic parking brake system, the brake system warning light turns on. Refer to “Electronic parking brake indicator light (models with electronic parking brake system)” 3-22.

### ■ Parking tips

When parking your vehicle, always perform the following items.

- Apply the parking brake firmly.
- For MT models, put the shift lever in the “1” (1st) for upgrade or “R” (Reverse) for a downgrade.
- For CVT models, put the select lever in the “P” (Park) position.

Never rely on the mechanical friction of the transmission alone to hold the vehicle.

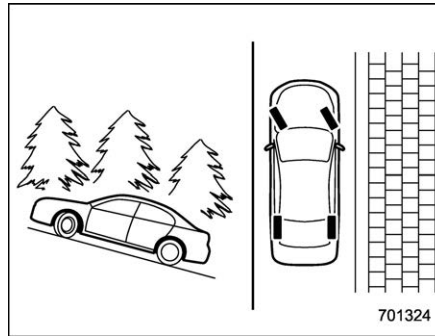

When parking on a hill, always turn the steering wheel. When the vehicle is headed up the hill, turn the front wheels away from the curb.

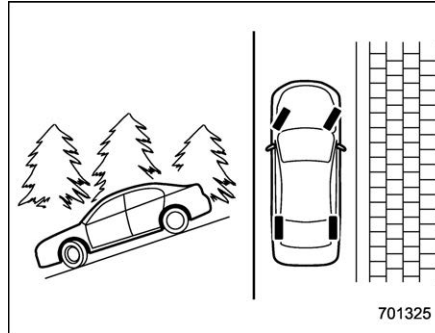

When facing downhill, turn the front wheels into the curb.

#### ⚠ WARNING

- Never leave unattended children or pets in the vehicle. They could accidentally injure themselves or others through inadvertent operation of the vehicle. Also, on hot or sunny days, the temperature in a closed vehicle could quickly become high enough to cause severe or possibly fatal injuries to people.
- Do not park the vehicle over flammable materials such as dry grass, waste paper or rags, as they may burn easily if they come near hot engine or exhaust system parts.
- Be sure to stop the engine if you take a nap in the vehicle. If engine exhaust gas enters the passenger compartment, occupants in the vehicle could die from carbon monoxide (CO) contained in the exhaust gas.

#### ⚠ CAUTION

If your vehicle has a front under-spoiler and rear under-spoiler (both optional), pay attention to blocks

and other obstructions on the ground when parking. The underspoilers could be damaged by contact with them.

### **Auto Vehicle Hold function (models with electronic parking brake system)**

The Auto Vehicle Hold function will automatically keep the vehicle stopped even after releasing the brake pedal when the vehicle is at a complete stop, such as at traffic signals.



#### **WARNING**

- Do not use the Auto Vehicle Hold function on a steep hill or slippery road. The vehicle may move even when using the Auto Vehicle Hold function, causing serious injury or accidents.
- Do not use the Auto Vehicle Hold function to park the vehicle. The vehicle may move unexpectedly, causing serious injury or accidents. Make sure to shift the select lever to the “P” position and apply the electronic parking brake in the following cases.
  - When you are going to park your vehicle
  - When passengers are getting in or out of the vehicle
  - When you are loading or un-

#### **loading**

- When using the Auto Vehicle Hold function, do not release the brake pedal before the Auto Vehicle Hold operation indicator illuminates. The vehicle may move unexpectedly, causing serious injury or accidents.
- Deactivate the Auto Vehicle Hold function in the following cases. Otherwise, the vehicle may move unexpectedly, causing serious injury or accidents.
  - When washing your vehicle in an automatic car wash
  - When being towed



#### **CAUTION**

When stopping on a steep slope with the Auto Vehicle Hold function turned on, the electronic parking brake may be automatically applied. Then the electronic parking brake indicator light will flash. In such a case, depress and hold the brake pedal while stopping. Otherwise, the vehicle may move.



**NOTE**

We recommend turning on the Auto Vehicle Hold function when stopping on an incline. If the Auto Vehicle Hold function is turned off, the vehicle may roll backward when driving off.

### ■ To turn on/off the Auto Vehicle Hold function

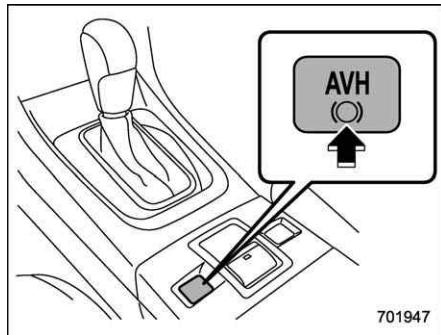

Auto Vehicle Hold switch

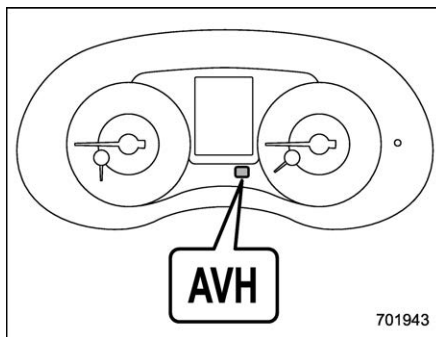

Auto Vehicle Hold ON indicator light

**To turn on:**

Press the Auto Vehicle Hold switch when the Auto Vehicle Hold ON indicator light is OFF. Then the Auto Vehicle Hold ON indicator light will illuminate.

Even after turning on the Auto Vehicle Hold function, it will automatically turn off once the ignition switch is turned to the "LOCK"/"OFF" position. The function will remain turned off when the ignition switch is turned back to the "ON" position.

**To turn off:**

Press the Auto Vehicle Hold switch when the Auto Vehicle Hold ON indicator light illuminates. Then the Auto Vehicle Hold ON indicator light will turn off.

**NOTE**

- If you press and hold the Auto Vehicle Hold switch for more than 30 seconds, the Auto Vehicle Hold ON indicator light will turn off, and the system will ignore any further pressing of the switch. To activate the switch again, restart the engine.
- When the Auto Vehicle Hold function is deactivated while the Auto Vehicle Hold function has a malfunction, if you press the Auto Vehicle Hold switch, a chirp will sound

### ■ To operate the Auto Vehicle Hold function

Stop the vehicle by depressing the brake pedal when all of the following conditions are met. Then the Auto Vehicle Hold function will operate.

- The driver's door is closed.
- The driver's seatbelt is fastened.
- The select lever is in a position other than the "P" position.

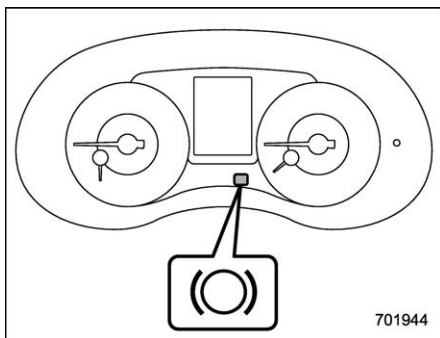

**Auto Vehicle Hold operation indicator light**

While the vehicle is kept stopped by the Auto Vehicle Hold function, the Auto Vehicle Hold operation indicator light will illuminate.

### ■ To release the Auto Vehicle Hold function

Perform any of the following operations to release the Auto Vehicle Hold function.

- Depress the accelerator pedal.
- Depress the brake pedal again.
- Apply the electronic parking brake.
- Shift the select lever to the “P” position with the brake pedal pressed.
- Press the Auto Vehicle Hold switch with the brake pedal pressed (The Auto Vehicle Hold function turns off).

When the Auto Vehicle Hold function is released, the Auto Vehicle Hold operation indicator light will turn off.

Under any of the following conditions, the Auto Vehicle Hold function will be automatically released and the electronic parking brake will be automatically applied.

- The Auto Vehicle Hold function has been in operation for 10 minutes.
- The driver’s seatbelt is unfastened.
- The driver’s door is opened.
- The ignition switch is turned to the “LOCK”/“OFF” position.
- The vehicle is stopped on a steep slope.
- The Auto Vehicle Hold function is malfunctioning.

In such cases, the Auto Vehicle Hold operation indicator light will turn off and the electronic parking brake indicator light will illuminate.

### ■ Tips

- When the electronic parking brake is automatically applied with the vehicle kept stopped by the Auto Vehicle Hold function, release the electronic parking brake by either of the following operations before starting off. Then make sure that the

electronic parking brake indicator light is off.

- Depress the accelerator pedal with the driver’s seatbelt fastened and with the doors closed.
- Press the electronic parking brake switch with the brake pedal depressed.
- Under certain conditions, including a malfunction of the Auto Vehicle Hold, a warning buzzer will sound and a warning message will appear on the combination meter display (color LCD). All warning messages should be strictly observed.
- On a steep slope, the vehicle cannot be kept stopped by the Auto Vehicle Hold function. In such a case, depress and hold the brake pedal.
- When stopping on a steep slope with the Auto Vehicle Hold function activated, the electronic parking brake may automatically be applied after stopping, then the electronic parking brake indicator light may flash. In such a case, depress and hold the brake pedal while stopped. Otherwise, the vehicle may move. When getting out of the vehicle, stop the vehicle on a flat surface, then apply the electronic parking brake.
- If the Auto Vehicle Hold ON indicator light does not illuminate even after pressing the Auto Vehicle Hold switch with the operating conditions met, the function

may have a malfunction. Contact your SUBARU dealer for an inspection.

- You may hear a sound while the Auto Vehicle Hold function is keeping your vehicle stopped. This is normal, and does not represent a malfunction.
- While the vehicle is kept stopped by the Auto Vehicle Hold function, the brake pedal may feel stiff. However, this is not a malfunction.
- When using the Auto Vehicle Hold function, depress the brake pedal firmly. Otherwise, the Auto Vehicle Hold may not operate.
- When the Auto Vehicle Hold switch is pressed and held for more than 30 seconds, the Auto Vehicle Hold ON indicator light will turn off and further operation of the switch will be ignored. To make the switch usable again, turn the ignition switch to the "LOCK"/"OFF" position and then turn it to the "ON" position.

## Hill start assist system

### WARNING

- **The Hill start assist system is a device only for helping the driver to START the vehicle on an uphill grade. To prevent accidents when the vehicle is parked on a slope, be sure to firmly set the parking brake. When setting the parking brake, make sure that the vehicle remains stationary when the clutch pedal (MT models) and brake pedal (both MT and CVT models) are released.**
- **Do not turn the ignition switch to the "LOCK"/"OFF" position while the Hill start assist system is operating. The Hill start assist system will be deactivated, causing an accident.**

## NOTE

For models with the electronic parking brake system:

- **The Hill start assist system will activate when the Auto Vehicle Hold function is deactivated.**
- **The Hill start assist system will deactivate when the Auto Vehicle Hold function is activated.**

The Hill start assist system is a device to make the following vehicle operations easier.

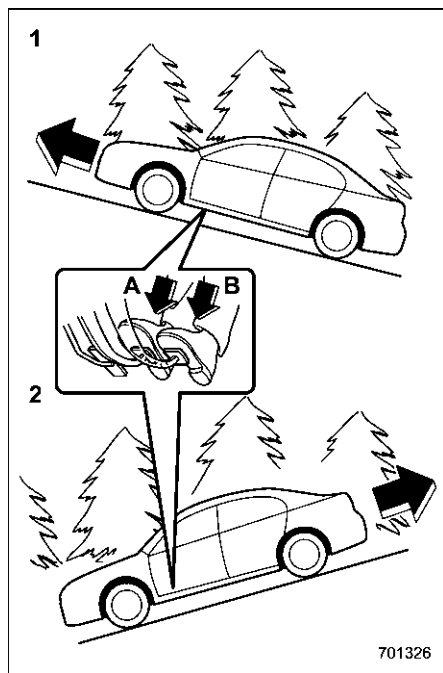

- 1) Starting forward facing uphill
- 2) Starting backward facing downhill
- A) Brake pedal
- B) Clutch pedal (MT models)

In both these cases, the Hill start assist system operates under the following conditions.

- When depressing both the clutch pedal and the brake pedal (MT models).
- When the vehicle has stopped with the brake pedal depressed (CVT models).

Braking power is maintained temporarily (for approximately 2 seconds) by the Hill start assist system after the brake pedal is released. The driver is therefore able to start the vehicle in the same way as on a level grade, just using the clutch pedal (MT models only) and accelerator pedal (all models).

If the braking power of the Hill start assist system is insufficient after the brake pedal is released, apply more braking power by depressing the brake pedal again.

The Hill start assist system may not operate on slight grades. Also, the Hill start assist system does not operate in the following cases.

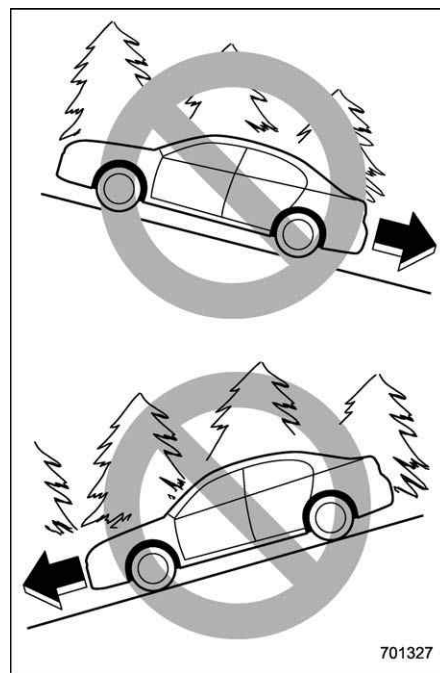

- When starting backward facing uphill.
- When starting forward facing downhill.
- While the parking brake is applied.
- While the ignition switch is in the “ACC” or “LOCK”/“OFF” position.
- While the Hill start assist warning light/

Hill start assist OFF indicator light is illuminated (models without the electronic parking brake system).

When using the Hill start assist system, a braking effect may be felt even after the brake pedal has been released. However, this braking effect should disappear once the clutch pedal is released.

## NOTE

**A slight jolt may be felt when the vehicle begins to move forward after being reversed.**

## ■ To activate/deactivate the Hill start assist system

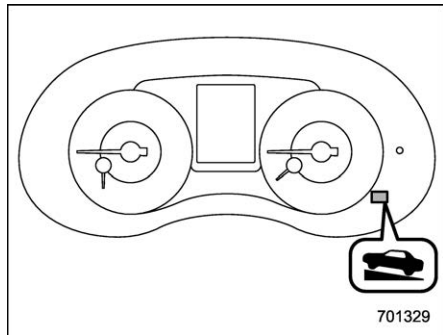

Hill start assist OFF indicator light

## ⚠ CAUTION

**When starting on an uphill grade, make sure the Hill start assist OFF indicator light is off. If the Hill start assist OFF indicator light is on, make sure the parking brake is applied.**

To activate and deactivate the Hill start assist system, perform the following steps.

## NOTE

**If you make an error when performing any steps in the following procedure, place the ignition switch in the “LOCK”/“OFF” position once and then start over again.**

### ▼ To deactivate

1. Park your vehicle in a flat and safe location and apply the parking brake.
2. Turn the ignition switch to the “LOCK”/“OFF” position.
3. Restart the engine.

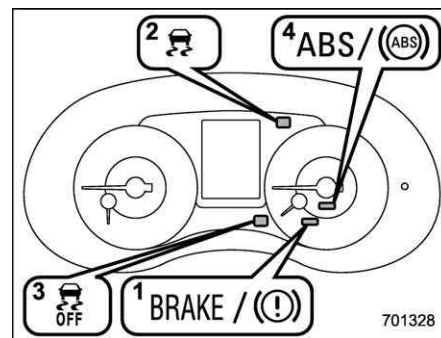

4. Confirm the following items.
  - (1) The Brake system warning light illuminates.
  - (2) The Vehicle Dynamics Control warning light turns off.
  - (3) The Vehicle Dynamics Control OFF indicator light turns off.
  - (4) The ABS warning light turns off.

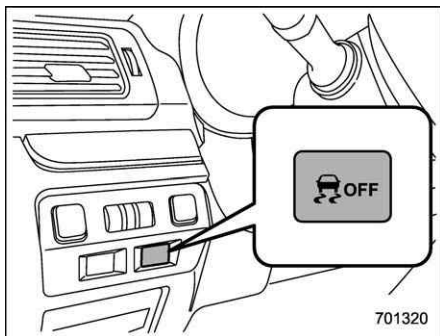

Vehicle Dynamics Control OFF switch

5. Press and hold the Vehicle Dynamics Control OFF switch for 30 seconds until the Vehicle Dynamics Control OFF indicator light "OFF" on the combination meter turns on and off.
6. Within 5 seconds, release the Vehicle Dynamics Control OFF switch.

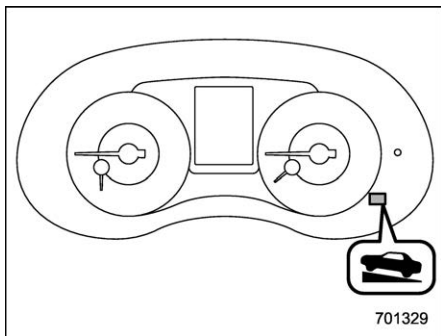

Hill start assist OFF indicator light

7. Within 2 seconds, press back the Vehicle Dynamics Control OFF switch. The Hill start assist OFF indicator light turns on and off.
8. Turn the ignition switch to the "LOCK"/"OFF" position. The Hill start assist system is deactivated.

### NOTE

When the Hill start assist system is deactivated, the Hill start assist OFF indicator light illuminates continuously.

### ▼ To reactivate

To reactivate the Hill start assist system, repeat steps 1 to 8. When the Hill start assist system is activated, the Hill start assist OFF indicator light turns off.

### ■ Hill start assist warning light/Hill start assist OFF indicator light (models without the electronic parking brake system)

Refer to "Hill start assist warning light/Hill start assist OFF indicator light (models without electronic parking brake system)" 3-24.

## Cruise control

### NOTE

For models with the EyeSight system: Refer to the Owner's Manual supplement for the EyeSight system.

Cruise control enables you to maintain a constant vehicle speed without holding your foot on the accelerator pedal and it is operative when the vehicle speed is 20 mph (30 km/h) or more.

### WARNING

- Do not use the cruise control under any of the following conditions. These may cause loss of vehicle control.
  - Driving up or down a steep grade
  - Driving on slippery or winding roads
  - Driving in heavy traffic
- When using the cruise control, always set the speed appropriately according to the speed limit, traffic flow, road conditions, and other conditions.

### NOTE

- On uphill and downhill slopes, depending on the degree of the slope and the load of the vehicle, there may be cases when a constant speed cannot be guaranteed.
- If the cruise control indicator does not appear even after pressing the cruise control main button, it is possible that there is a malfunction in the system. We recommend that you contact your SUBARU dealer for an inspection.
- Make sure the cruise control system is turned off when the cruise control is not in use to avoid unintentionally setting the cruise control.

### ■ To set cruise control

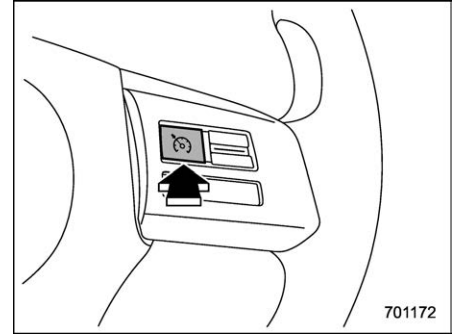

Cruise control main button

1. Press the cruise control main button.

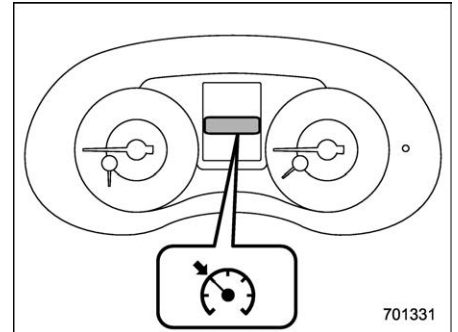

Cruise control indicator

The cruise control indicator on the combi-

nation meter will appear.

2. Depress the accelerator pedal until the vehicle reaches the desired speed.

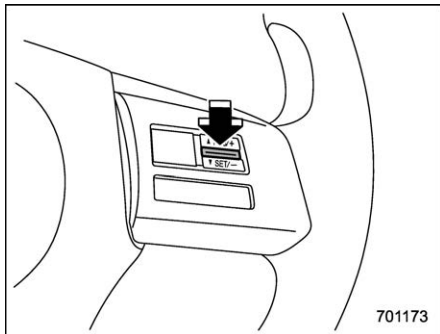

3. Press the “RES/SET” switch to the “SET” side and release it. Then release the accelerator pedal.

**NOTE**

**Except STI: When setting a cruise speed for the first time during a drive, both “SET” and “RES” may be used to set the initial cruise speed.**

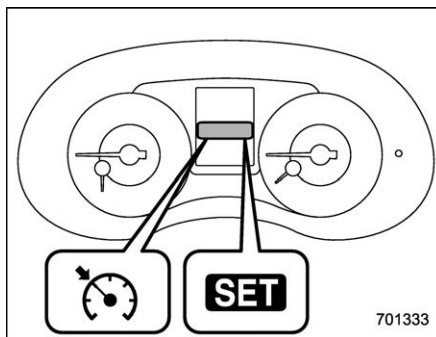

**Cruise control set indicator**

At this time, the cruise control set indicator appears in the combination meter. The vehicle will maintain the desired speed.

You can temporarily increase the vehicle speed while driving with the cruise control activated. Simply depress the accelerator pedal to accelerate the vehicle. When you release the accelerator pedal, the vehicle will return to and maintain the previous cruising speed.

**NOTE**

For CVT models, when you set the desired speed while the Sport Sharp (S#) mode is selected, the select lever/gear position indicator will change from the current gear position indica-

tion to the “D” indication.

**■ To temporarily cancel the cruise control**

You can temporarily cancel the cruise control in the following ways.

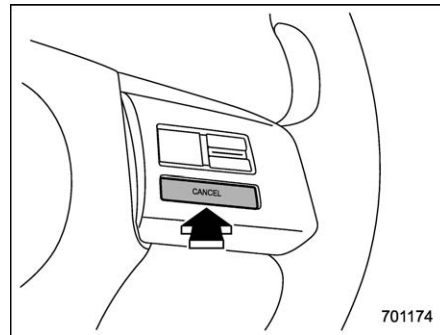

- Press the “CANCEL” button.
- Depress the brake pedal.
- Depress the clutch pedal (MT models only).

**⚠ WARNING**

For CVT models, you can cancel the cruise control by shifting the select lever into the “N” position. However, do not shift the lever into the “N” position while driving except in case of emergency. If the select lever is



**shifted into the “N” position, the engine brake will no longer work. This could result in an accident.**

The cruise control set indicator in the combination meter disappears when the cruise control is canceled.

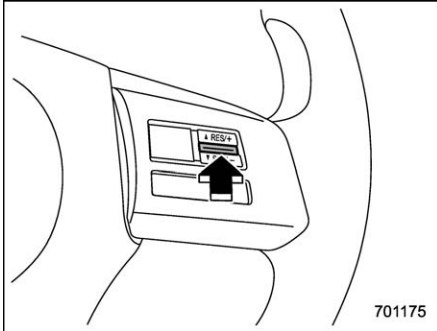

To resume the cruise control after it has been temporarily canceled and with vehicle speed of approximately 20 mph (30 km/h) or more, press the “RES/SET” switch to the “RES” side to return to the original cruising speed automatically.

The cruise control set indicator in the combination meter will automatically appear at this time.

## ■ To turn off the cruise control

There are two ways to turn off the cruise control:

- Press the cruise control main button again.
- Turn the ignition switch to the “ACC” or “LOCK”/“OFF” position (but only when the vehicle is completely stopped).

## ■ To change the cruising speed

### ▼ To increase the speed (by the “RES/SET” switch)

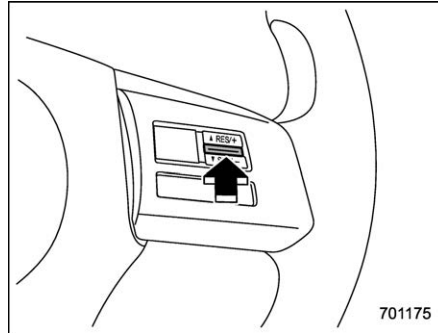

Press the “RES/SET” switch to the “RES” side and hold it until the vehicle reaches the desired speed. Then, release the switch. The vehicle speed at that moment will be memorized and treated as the new set speed.

You can increase the set speed 1 mph (1.6 km/h) or 1 km/h (0.6 mph) each time by pressing the “RES/SET” switch to the “RES” side quickly.

### ▼ To increase the speed (by accelerator pedal)

1. Depress the accelerator pedal to accelerate the vehicle to the desired speed.
2. Press the “RES/SET” switch to the “SET” side once. Now the desired speed is set and the vehicle will keep running at that speed without depressing the accelerator pedal.

## NOTE

**CVT models:**

- If you depress the accelerator pedal with the Sport Sharp (S#) mode selected, the select lever/gear position indicator may change from the “D” indication to the current gear position indication.
- If you depress the accelerator pedal fully with the Intelligent (I) mode or the Sport (S) mode selected, the transmission will operate like a conventional automatic transmission.

▼ To decrease the speed (by the “RES/SET” switch)

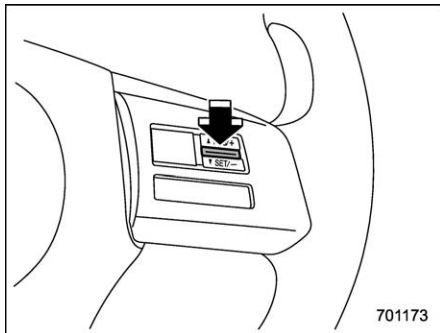

Press the “RES/SET” switch to the “SET” side and hold it until the vehicle reaches the desired speed. Then, release the switch. The vehicle speed at that moment will be memorized and treated as the new set speed.

You can lower the set speed 1 mph (1.6 km/h) or 1 km/h (0.6 mph) each time by pressing the “RES/SET” switch to the “SET” side quickly.

▼ To decrease the speed (by brake pedal)

1. Depress the brake pedal to release cruise control temporarily.
2. When the speed decreases to the desired speed, press the “RES/SET” switch to the “SET” side once. Now the desired speed is set and the vehicle will keep running at that speed without depressing the accelerator pedal.

■ Cruise control indicator

Refer to “Cruise control indicator” 3-35.

■ Cruise control set indicator

Refer to “Cruise control set indicator” 3-35.

## BSD/RCTA (if equipped)

The BSD/RCTA consists of rear corner radar with Blind Spot Detection and Rear Cross Traffic Alert.

These functions enable the system to detect objects or vehicles to the rear, drawing attention to the driver when changing a lane or when driving in reverse.



### WARNING

**The driver is responsible for driving safely. Always be sure to check the surroundings with your eyes when changing lanes or reversing the vehicle.**

**The system is designed to assist the driver in changing lanes or reversing safely by monitoring the rear and side areas of the vehicle. However, you cannot rely on this system alone in assuring the safety during a lane change or reversing. Overconfidence in this system could result in an accident and lead to serious injury or death. Since the system operation has various limitations, the flashing or illumination of the BSD/RCTA approach indicator light may be delayed or it may not operate at all even when a vehicle is present**

in a neighboring lane or approaching from either side.

The driver is responsible for paying attention to the rear and side areas of the vehicle.

## ■ System features

BSD/RCTA consists of the following functions.

- To detect a vehicle in a blind spot on an adjacent lane or a vehicle approaching at high speed while driving the vehicle (Blind Spot Detection)
- To detect a vehicle approaching from the right or left while reversing the vehicle (Rear Cross Traffic Alert)

The system uses radar sensors for the following features.

## NOTE

The BSD/RCTA radar sensor has been certified by the radio wave related laws of the U.S., Canada and Mexico. When driving in other countries, certification of the country where the vehicle is driven must be obtained. For certification in the U.S., Canada and Mexico, refer to “Certification for the BSD/RCTA” 7-63.

## ▼ Blind Spot Detection (BSD)

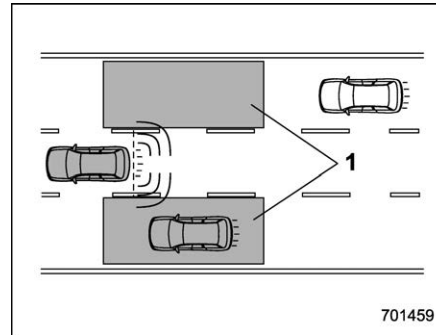

1) Operating range

The system warns the driver of dangers as follows.

- If the system detects vehicles in the driver's blind spots, the BSD/RCTA approach indicator light(s) on the outside mirror(s) will illuminate.
- If the driver operates the turn signal lever to the side where the BSD/RCTA approach indicator light is illuminated, the corresponding BSD/RCTA approach indicator light will flash.

## ▽ Lane Change Assist (LCA)

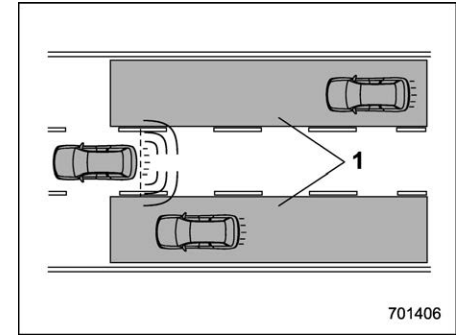

1) Operating range

The system warns the driver of dangers as follows.

- If the system detects vehicles approaching at high speeds in the neighboring lanes, the BSD/RCTA approach indicator light(s) on the outside mirror(s) will illuminate.
- If the driver operates the turn signal lever to the side where the BSD/RCTA approach indicator light is illuminated, the corresponding BSD/RCTA approach indicator light will flash.

▼ Rear Cross Traffic Alert (RCTA)

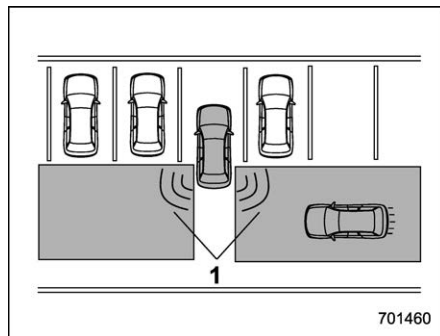

1) Operating range

The system notifies the driver of another vehicle approaching from either side when driving in reverse. This feature helps the driver check the rear and side areas of the vehicle when moving backward.

If the system detects a vehicle approaching from either side while moving backward, it warns the driver of dangers in the following way.

- The BSD/RCTA approach indicator light(s) on the outside mirror(s) flashes.
- A warning buzzer sounds.

▽ Limitations of the detectability of RCTA

Since the detectability of RCTA is limited, the RCTA may not operate properly in angled parking.

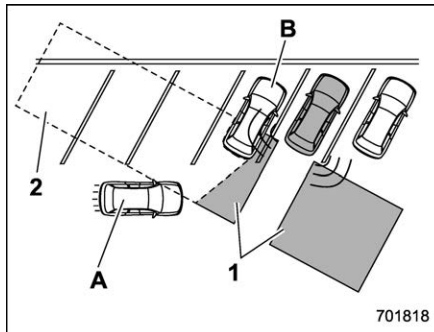

**Example 1**

- 1) The detection range of the radar sensors
  - 2) Area out of detection range of the radar sensors
- A) Vehicle that may not be detected  
B) Parked vehicle

**⚠ WARNING**

**An approaching vehicle (A) may not be detected because the detection range is limited by the parked vehicle (B). Always be sure to check the surroundings with your eyes when**

**reversing the vehicle.**

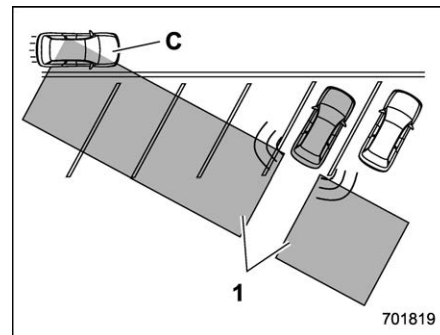

**Example 2**

- 1) The detection range of the radar sensors
- C) Vehicle that may be detected

**NOTE**

**The system may detect that a vehicle (C) is passing in front of your vehicle. Always be sure to check the surroundings with your eyes when reversing the vehicle.**

## ■ System operation

### ▼ Operating conditions

The BSD/RCTA will operate when all of the following conditions are met.

- The ignition switch is in the “ON” position.
- The BSD/RCTA warning indicator and BSD/RCTA OFF indicator are turned off.
- The vehicle speed is above 7 mph (12 km/h) (except when reversing).
- The shift lever/select lever is in the “R” position (RCTA only).

The BSD/RCTA will not operate in the following situations.

- The BSD/RCTA OFF indicator is on.
- The vehicle speed is below 6 mph (10 km/h) even when the BSD/RCTA OFF indicator remains off (except when reversing).

### NOTE

- When a malfunction occurs in the system (including the BSD/RCTA approach indicator light), the BSD/RCTA will stop operating and the BSD/RCTA warning indicator will appear.
- If the BSD/RCTA warning indicator appears, exercise proper caution. For details, refer to “BSD/RCTA warning indicator” 7-62.

- In the following cases, the BSD/RCTA will temporarily stop operating (or may stop operating) and the BSD/RCTA OFF indicator will appear.

- When the radar sensor becomes significantly misaligned (If the orientation of the radar sensor is shifted for any reason, readjustment is required. Have the sensor adjusted at a SUBARU dealer.)
- When a large amount of snow or ice sticks to the rear bumper surface around the radar sensors
- When the vehicle is driven on a snow-covered road or in an environment in which there are no objects around (such as in a desert) for a prolonged period of time
- When the temperature around the radar sensors increases excessively due to long driving on uphill grades in the summer, etc.
- When the temperature around the radar sensors becomes extremely low
- When the vehicle battery voltage lowers
- When the vehicle voltage exceeds the battery voltage rating

The BSD/RCTA will resume operation once these conditions are cor-

rected, and the BSD/RCTA OFF indicator will disappear. However, if the BSD/RCTA OFF indicator appears for a prolonged period of time, have the system inspected at a SUBARU dealer as soon as possible.

- The detectability of the radar sensors is restricted. The BSD/RCTA detection may be impaired and the system may not operate properly under the following conditions.
  - When the rear bumper around the radar sensors is distorted
  - When ice, snow or mud adheres to the rear bumper surface around the radar sensors
  - When stickers, etc. are affixed on the areas of the radar sensors on the rear bumper
  - During adverse weather conditions such as rain, snow or fog
  - When driving on wet roads such as snow-covered roads and through puddles
- The radar sensors may not detect or may have difficulty detecting the following vehicles and objects.
  - Small motorcycles, bicycles, pedestrians, stationary objects on the road or road side and etc.
  - Vehicles with body shapes that

the radar may not reflect (vehicles with lower body height such as sports cars or a trailer with no cargo)

- Vehicles that are not approaching your vehicle even though they are in the detection area (either on a neighboring lane to the rear or beside your vehicle when reversing) (The system determines the presence of approaching vehicles based on data detected by the radar sensors.)
- Vehicles traveling at significantly different speeds
- Vehicles driving in parallel at almost the same speed as your vehicle for a prolonged time
- Oncoming vehicles
- Vehicles in a lane beyond the neighboring lane
- Vehicles travelling at a significantly lower speed that you are trying to overtake
- On a road with extremely narrow lanes, the system may detect vehicles driving in a lane next to the neighboring lane.
- When the 7-inch audio/navigation system is performing a software update, the RCTA warning icons may not be displayed on the audio/navigation

screen until the update is complete.

### ■ BSD/RCTA approach indicator light/warning buzzer

While the BSD/RCTA is active, the following item(s) will operate to alert the driver:

- The BSD/RCTA approach indicator light (when there are vehicles in the neighboring lanes).
- The BSD/RCTA approach indicator light and warning buzzer (when a vehicle is approaching from the left or right side while reversing).

### ▼ BSD/RCTA approach indicator light

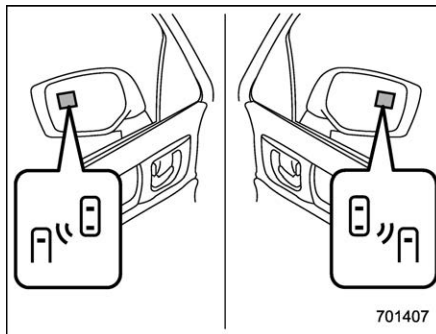

BSD/RCTA approach indicator light

It is mounted on each side of the outside mirrors.

The indicator light will illuminate when a vehicle approaching from behind is detected.

The indicator light will flash to warn the driver of dangers under the following conditions.

- While the indicator light is illuminating, if the turn signal lever is operated toward the side in which this light turned on
- When reversing the vehicle while the system detects a vehicle approaching from either side

### ▽ BSD/RCTA approach indicator light dimming function

When the headlights are on, the brightness of the BSD/RCTA approach indicator light will be reduced.

### NOTE

- You may have difficulty seeing the BSD/RCTA approach indicator light under the following conditions.
  - When sunlight shines directly on it
  - When the headlight beams from a vehicle traveling behind shines directly on it
- While the illumination brightness control dial is in the fully upward position, even if the headlights are turned on, the brightness of the BSD/

**RCTA approach indicator light will not be reduced. For details about the illumination brightness control dial, refer to “Illumination brightness control” 3-72.**

▼ **BSD/RCTA approach warning buzzer (only when reversing)**

A warning buzzer sounds along with flashing of the BSD/RCTA approach indicator light to warn the driver of dangers.

You can change the setting of the warning buzzer volume by operating the combination meter display (color LCD). For details, refer to “BSD/RCTA” 3-43.

▼ **Safety tips regarding the BSD/RCTA approach indicator light/warning buzzer**

- In the following cases, operation of the BSD/RCTA approach indicator light and the warning buzzer may be delayed or the system may fail to issue these warnings.
  - When a vehicle moves to the neighboring lane from a lane next to the neighboring lane
  - When you are driving on a steep incline or on repeated sharp uphill and downhill grades
  - When you are going beyond a pass
  - When both your vehicle and a vehicle driving on a neighboring lane

are driving on the far side of each lane.

- When several narrowly-spaced vehicles are approaching in a row
  - In low radius bends (tight bends or when making turns at an intersection)
  - When there is a difference in height between your lane and the neighboring lane
  - Immediately after the BSD/RCTA is activated by pressing the BSD/RCTA OFF switch
  - Immediately after the shift lever/select lever is shifted to the “R” position
  - When extremely heavy cargo is loaded in the trunk
- During reversing, operation of the BSD/RCTA approach indicator light and the warning buzzer may be delayed or the system may fail to issue these warnings under the following conditions.
    - When backing out of an angled parking space
    - When a large-sized vehicle is parked next to your vehicle (That vehicle prevents the propagation of radar waves.)
    - When reversing on sloped roads
    - When reversing at a high speed

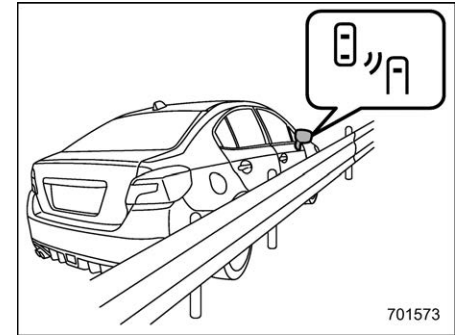

- The BSD/RCTA approach indicator light may illuminate when driving close to solid objects on the road or road side (such as guardrails, tunnels and sidewalls).
- The BSD/RCTA approach indicator light may flash when turning at an intersection in urban areas or multilane intersections.
- The BSD/RCTA approach indicator light may flash and the warning buzzer may sound if a building or a wall is in the reversing direction.
- In the following cases, the system may detect a vehicle driving two lanes away from your vehicle.
  - When your vehicle drives on the near side of its lane from the corresponding vehicle
  - When the vehicle driving two lanes

away drives on the near side of its lane from your vehicle

## ■ BSD/RCTA OFF indicator

### ▼ System temporary stop

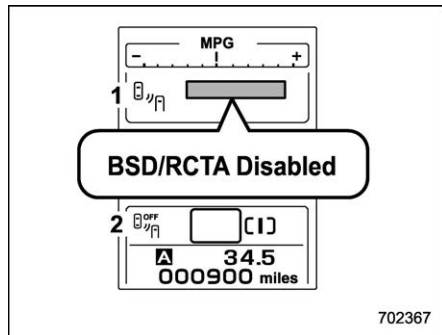

- 1) BSD/RCTA temporary stop message
- 2) BSD/RCTA OFF indicator

This display appears when the system is used under the following conditions.

- Extremely high or low temperatures
- When abnormal voltage exists for the vehicle battery
- When the radar sensor is significantly misaligned

Once these conditions are corrected, the system will recover from the temporary stop condition and the indicator will dis-

appear.

If the indicator remains displayed for a prolonged time, have the system inspected at a SUBARU dealer.

### ▼ System temporary stop due to reduced radar sensitivity

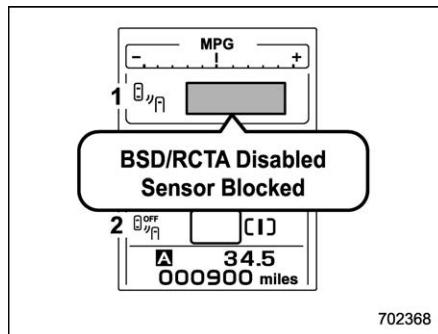

- 1) BSD/RCTA temporary stop message due to reduced radar sensitivity
- 2) BSD/RCTA OFF indicator

This display appears when the detectability of the radar sensors is reduced. Once the condition is corrected, the system will recover from the temporary stop condition and the indicator will disappear.

If the indicator remains displayed for a prolonged time, have the system inspected at a SUBARU dealer.

## ■ BSD/RCTA warning indicator

### ▼ System malfunction

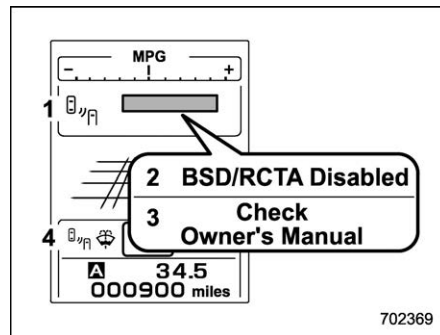

- 1) BSD/RCTA malfunction message
- 2) "BSD/RCTA Disabled" message
- 3) "Check Owner's Manual" message
- 4) BSD/RCTA warning indicator

The "BSD/RCTA Disabled" message and "Check Owner's Manual" message are shown alternately.

This display appears when a malfunction occurs in the system. Contact a SUBARU dealer and have the system inspected.



## ■ BSD/RCTA OFF switch

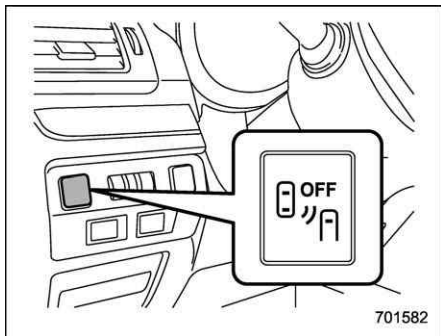

BSD/RCTA OFF switch

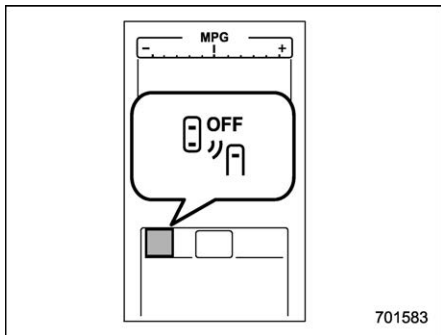

BSD/RCTA OFF indicator

Press the BSD/RCTA OFF switch to deactivate the BSD/RCTA. Then the BSD/RCTA OFF indicator light will appear

on the combination meter display (color LCD).

Press the switch again to activate the BSD/RCTA. The BSD/RCTA OFF indicator disappears.

### NOTE

- In the following cases, press the BSD/RCTA OFF switch to deactivate the system. The system may not operate properly due to blocked radar waves.

- When a bicycle carrier or other item is fitted to the rear of the vehicle
- When using a chassis dynamometer or free roller device, etc.
- When running the engine and making the wheels rotate while lifting up the vehicle

- If you turn the ignition switch to the “LOCK”/“OFF” position, the last known status of the system is maintained. For example, if you turn the ignition switch to the “LOCK”/“OFF” position with the BSD/RCTA deactivated, the BSD/RCTA remains deactivated the next time you turn the ignition switch to the “ON” position.

## ■ Certification for the BSD/RCTA

- U.S.-spec. models

FCC ID: OAYSRR3A



**CAUTION**

### FCC WARNING

Changes or modifications not expressly approved by the party responsible for compliance could void the user's authority to operate the equipment.

This device complies with part 15 of the FCC Rules. Operation is subject to the following two conditions: (1) This device may not cause harmful interference, and (2) this device must accept any interference received, including interference that may cause undesired operation.

• **Canada-spec. models**

**NOTE**

This device contains licence-exempt transmitter(s)/receiver(s) that comply with Innovation, Science and Economic Development Canada's licence-exempt RSS(s). Operation is subject to the following two conditions:

1. This device may not cause interference.
2. This device must accept any interference, including interference that may cause undesired operation of the device.

Radiofrequency radiation exposure information:

This equipment complies with radiation exposure limits set forth for an uncontrolled environment. This equipment should be installed and operated with minimum distance of 20 cm between the radiator and your body.

702692

**REMARQUE**

L'émetteur/récepteur exempt de licence contenu dans le présent appareil est conforme aux CNR d'Innovation, Sciences et Développement économique Canada applicables aux appareils radio exempts de licence. L'exploitation est autorisée aux deux conditions suivantes:

1. L'appareil ne doit pas produire de brouillage;
2. L'appareil doit accepter tout brouillage radioélectrique subi, même si le brouillage est susceptible d'en compromettre le fonctionnement.

Informations sur l'exposition aux rayonnements radiofréquences:

Cet équipement est conforme aux limites d'exposition aux rayonnements définies pour un environnement non contrôlé. Cet équipement doit être installé et utilisé avec un minimum de 20 cm de distance entre la source de rayonnement et votre corps.

702693

• **Mexico-spec. models**

Certificado de homologacion:  
RLVCOSR15-0442

Continental SRR3-A

Este equipo opera a título secundario, consecuentemente, debe aceptar interferencias perjudiciales incluyendo equipos de la misma clase y puede no causar interferencias a sistemas operando a título primario.

500612

## ■ Handling of radar sensors

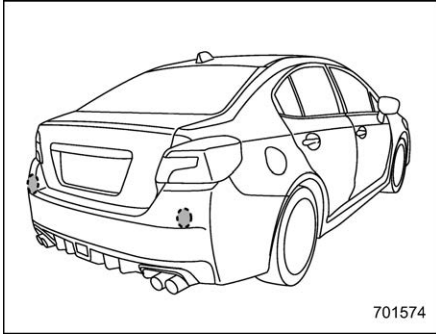

**Radar sensors**

The radar sensors, one on each side of the vehicle, are mounted inside the rear bumper.

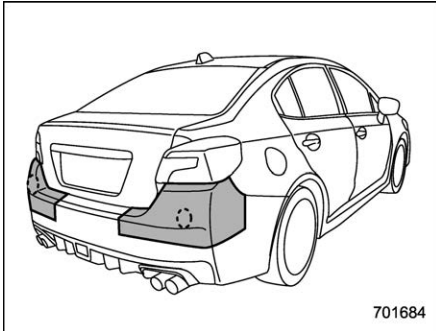

### CAUTION

To ensure correct operation of the BSD/RCTA, observe the following precautions.

- Always keep the bumper surface near the radar sensors clean.
- Do not affix any stickers or other items on the bumper surface near the radar sensors.
- Do not modify the bumper near the radar sensors.
- Do not paint the bumper near the radar sensors.
- Do not expose the bumper near the radar sensors to strong impacts. If a sensor becomes misaligned, a system malfunction may occur, including the inability to detect vehicles entering the detection areas. If any strong shock is applied to the bumper, be sure to contact your SUBARU dealer for inspection.
- Do not disassemble the radar sensors.

### NOTE

If the radar sensors require repair or replacement, or the bumper area

around the radar sensors requires repair, paintwork or replacement, contact your SUBARU dealer for assistance.

## Reverse Automatic Braking (RAB) system (if equipped)

Reverse Automatic Braking (RAB) is a system designed to help avoid collisions or reduce collision damage when reversing the vehicle. If a wall or an obstacle is detected in the reversing direction, the system will notify the driver with a warning sound and may activate the vehicle's brakes automatically.



### WARNING

- **Reverse Automatic Braking (RAB) is not a system intended to replace the driver's responsibility to check surrounding areas for vehicles or obstacles to avoid a collision.**
- **The driver is responsible for driving safely. Before reversing, be sure to first depress the brake pedal and visually check the surroundings.**
- **There are some cases in which the vehicle cannot avoid collision, because the system operation has limitations. The warning sound or automatic braking may be delayed or may not operate at all even when an obstacle is**

present.

- **The system is not designed to detect people (including children), animals or other moving objects.**
- **Depending on the vehicle condition or the surrounding environment, the sonar sensor's ability to detect objects may become unstable.**

### NOTE

The Reverse Automatic Braking (RAB) system records and stores the following data when automatic braking operates. It does not record conversations, personal information or other audio data.

- **Distance from the object**
- **Vehicle speed**
- **Accelerator pedal operation status**
- **Brake pedal operation status**
- **Select lever position**
- **Outside temperature**
- **The sensitivity setting of the sonar sensors**

SUBARU and third parties contracted by SUBARU may acquire and use the recorded data for the purpose of vehicle research and

development. SUBARU and third parties contracted by SUBARU will not disclose or provide the acquired data to any other third party except under the following conditions.

- **The vehicle owner has given his/her consent.**
- **The disclosure/provision is based on a court order or other legally enforceable request.**
- **Data that has been modified so that the user and vehicle cannot be identified is provided to a research institution for statistical processing or similar purposes.**

### ■ Reverse Automatic Braking (RAB) system overview

The system detects objects using sonar sensors installed in the rear bumper. If the system determines a possible collision with an object in the reversing direction, automatic deceleration will be activated. Also, beeping sounds will activate. If the vehicle is further reversed, automatic hard braking will be applied and a continuous beeping sound will activate.

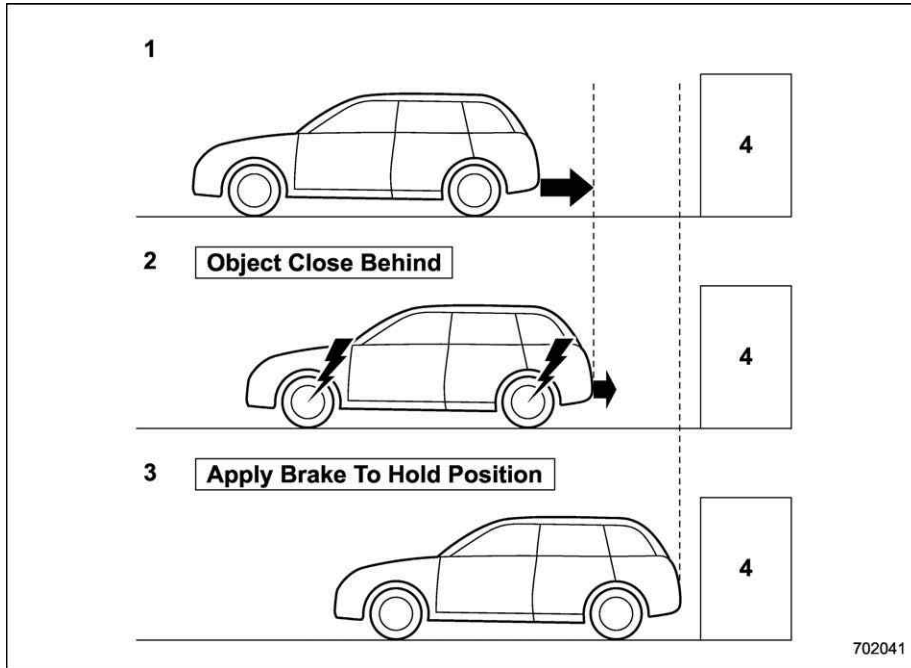

- 1) When reversing
- 2) When either strong automatic braking or torque control is applied to prevent collision (in this case, short warning beeps or continuous warning beeps will sound)
- 3) When the vehicle is stopped by the system (in this case, the continuous beep will remain sounding)
- 4) Object (e.g., a wall)

▼ **Detecting range**

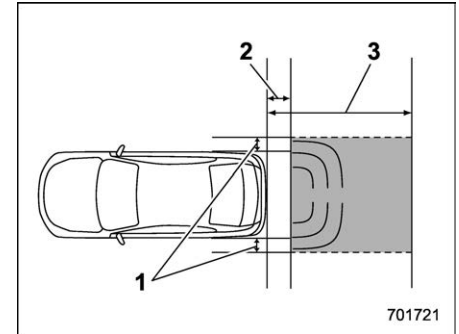

- 1) Detecting range (width): Approximately 6 in (15 cm) outside of the vehicle width
- 2) Range that the system cannot detect: Approximately 20 in (50 cm) behind the rear of the vehicle
- 3) Detecting range (length): Approximately 5 ft (1.5 m) from the rear of the vehicle

**⚠ WARNING**

**If your vehicle is trapped on a railroad crossing and you are trying to escape by reversing through the crossing gate, the system may recognize the crossing gate as an obstacle and the brakes may activate. In this case, remain calm and either continue to depress the accelerator pedal or cancel the system. To**

cancel the system, refer to “Canceling the Reverse Automatic Braking (RAB) system operation” 7-74.

## Operating conditions

The Reverse Automatic Braking (RAB) system will operate when all of the following conditions are met.

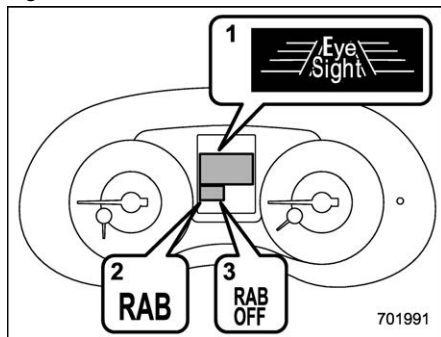

- 1) EyeSight warning indicator
- 2) RAB warning indicator
- 3) RAB OFF indicator

- The ignition switch is in the “ON” position.
- The EyeSight warning indicator is off.
- The RAB warning indicator is off.
- The RAB OFF indicator is off.
- The Reverse Automatic Braking (RAB)

system is set to on.

- The select lever is in the “R” position.
- The vehicle speed is between 1 to 9 mph (1.5 to 15 km/h).

## NOTE

- When the RAB warning indicator is illuminated, the Reverse Automatic Braking (RAB) system cannot be operated. Promptly contact a SUBARU dealer to have the system inspected.
- When the RAB OFF indicator is illuminated, the Reverse Automatic Braking (RAB) system cannot be operated.
- In the following cases, the system may not be able to properly detect an obstacle. Promptly contact a SUBARU dealer to have the system inspected.
  - A sticker, paint, or a chemical is applied to the sonar sensors or the rear bumper near the sonar sensor.
  - The rear bumper is modified.
  - The rear bumper has been removed and reattached.
  - The ground clearance is changed due to the vehicle’s loading condition or modification.
  - Ice, snow or mud is adhered to the sonar sensors or the rear bumper near the sonar sensor.
  - The rear bumper is exposed to

strong impact, or the rear bumper is deformed.

- When the 7-inch audio/navigation system is performing a software update, the Reverse Automatic Braking (RAB) system may not display the following items on the audio/navigation screen until the update is complete.
  - Display Icon on/off Function
  - Distance Indicator Image
  - Warning Message
- On a steep hill, the system’s automatic braking ability will be reduced.
- The system is designed to avoid collisions by automatic hard braking when the vehicle’s reversing speed is less than approximately 3 mph (5 km/h). However, the system does not guarantee that the vehicle will be able to avoid collisions in any situation.
- If the vehicle is reversed at an extremely slow speed, the driver’s operation may be prioritized. In this case, automatic braking will not operate.
- The system may not be able to detect the following objects.
  - Sharp or thin objects such as poles, fences and ropes which may not reflect the sound wave emitted from the sonar sensor.

- Objects that are too close to the rear bumper when the select lever is set to the “R” position.
- Objects with a surface which may not reflect the sound wave emitted from the sonar sensor such as a chain link fence.
- Objects the system is not designed to detect.
  - Pedestrians
  - Moving objects including moving vehicles
  - Objects which absorb sound waves such as cloth or snow.
  - Objects whose surface has a diagonal angle.
  - Objects that are low to the ground such as parking blocks.
  - Objects that are high above the ground such as objects hanging from above.
- The system may not be able to properly detect objects or may cause a system malfunction when the following conditions exist.

High frequency sound from other sources are nearby:

- Horn sound from another vehicle
- Engine sound from other vehicles
- Sound of an air brake

- Vehicle detection equipment or a sonar from another vehicle
- A sound wave with a frequency similar to the vehicle's system is transmitted nearby.
- A vehicle equipped with the same system is reversing toward your reversing direction.

Weather conditions:

- Extremely high or extremely low temperatures in which the area near the sonar sensor becomes too hot or too cold to operate.
- The sonar sensors or the rear bumper near the sonar sensors is exposed to heavy rain or a significant amount of water.
- Fog, snow or sandstorm, etc.
- Air is moving rapidly such as when a strong wind is blowing.

Parts attached to the rear bumper near the sonar sensor:

- Commercial electronic parts (fog light, fender pole, radio antenna) or commercial attachment parts (trailer hitch, bicycle carrier, bumper guard) are attached.
- Parts that emit high frequency sound, such as a horn or speaker, are attached.

Vehicle conditions:

- The vehicle is significantly inclined.
- The ground clearance is significantly reduced due to the vehicle's loading condition, etc.
- When the sonar sensor is misaligned due to a collision or an accident.

Surrounding environment:

- A cloth banner, flag, hanging branch or railroad crossing bars are present in the reversing direction.
- When reversing on a gravel or grassy area.
- When reversing in an area where objects or walls are adjacent to the vehicle such as narrow tunnels, narrow bridges, narrow roads or narrow garages.
- Wheel tracks or a hole is present in the ground of the reversing direction.
- When reversing over a drainage cover (grate cover).

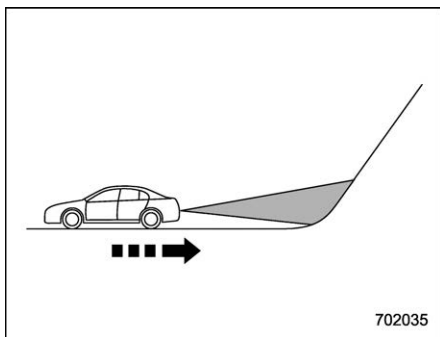

702035

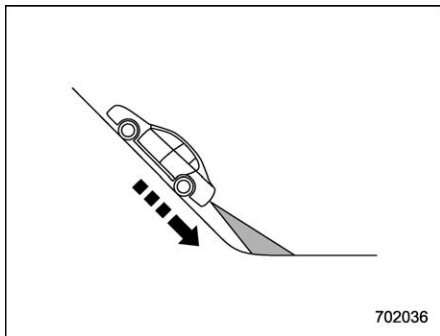

702036

- The path of the reversing direction is inclined, such as on a steep uphill.
- A curb is present in the reversing direction.
- When reversing downhill.

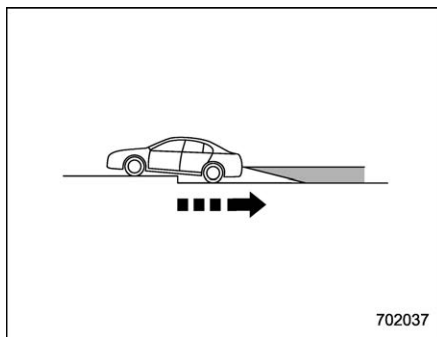

702037

- When reversing on an uneven road.
- In circumstances such as the following, it may not be possible to avoid a collision even when the system operates normally.
  - The roads are slippery.
  - The tire air pressure is not correct.
  - The tires have become worn.
  - Tire chains are installed.
  - Tires which are not the designated size are installed.
  - Emergency repairs were performed using a puncture repair kit.
  - The suspension was modified.
  - Vehicle driving is unstable due to accident or malfunction.

- The brake warning light is illuminated.

### ■ Reverse Automatic Braking (RAB) system operation

When the Reverse Automatic Braking (RAB) system is in operation, the range between the vehicle and the detected object will be indicated on the multi-function display (color LCD). Also, warning sounds will activate in 3 levels to warn the driver of a potential collision.

While the RAB is operating, a warning message is displayed on the multi-function display (color LCD) and the combination meter display (color LCD).



Guideline of detecting range

Alert level	Range of detected object*	Distance indicator	Alarm pattern
Long proximity alert (object detected)	35 in (90 cm) or more	Green	No warning sound
Medium proximity alert (approaching the object)	28 to 35 in (70 to 90 cm)	Yellow + Green	Short beeps
Close proximity alert (approaching closer to the object)	20 to 28 in (50 to 70 cm)	Orange + Yellow + Green	Rapid short beeps
Closest proximity alert (too close to the object)	20 in (50 cm) or less	Red + Orange + Yellow + Green	Continuous beep

\*: Range of detection may vary depending on the environmental condition.

▼ **Obstacle detected and Alert level**

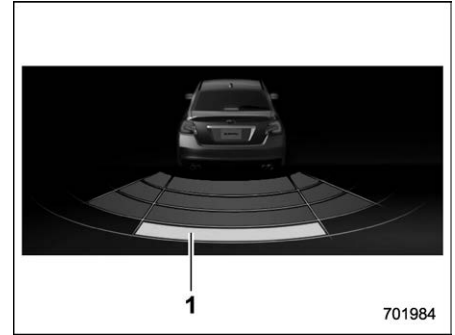

**Long proximity alert (object detected)**

- 1) Green: 35 in (90 cm) or more

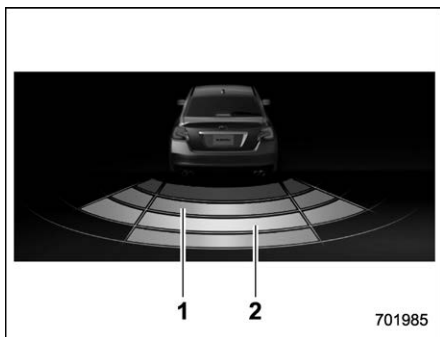

**Medium and close proximity alert (approaching the object and approaching closer to the object)**

- 1) Orange: 20 to 28 in (50 to 70 cm)
- 2) Yellow: 28 to 35 in (70 to 90 cm)

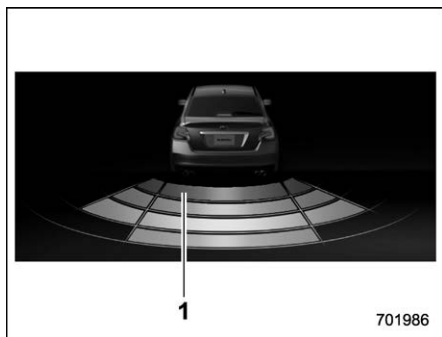

**Closest proximity alert (too close to the object)**

- 1) Red: 20 in (50 cm) or less

When an object is detected in the reversing direction, the range of detected object will be shown on the multi-function display (color LCD).

A warning alarm will sound and, depending on the speed, either torque control to generate engine braking or automatic braking will be applied.

▼ **Object close behind warning**

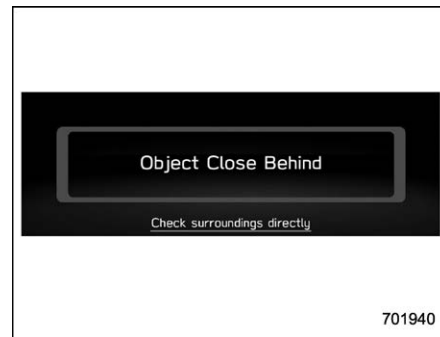

**Automatic braking warning**

If the vehicle continues to go in reverse, the system may determine the risk of collision with the object. In this case, short warning beeps or continuous warning beeps will sound and either strong automatic braking or torque control will be applied to prevent collision.

At this time, a warning message is also displayed on the combination meter display (color LCD).

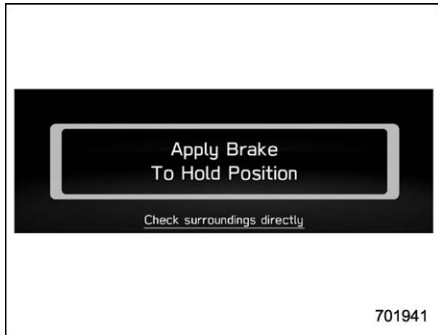

701941

#### Depress brake pedal warning

Make sure to depress the brake pedal once the vehicle has been stopped by automatic braking. Until the brake pedal is depressed, a message will be displayed on the multi-function display (color LCD) and the continuous beep will remain sounding.

At this time, a warning message is also displayed on the combination meter display (color LCD).



#### WARNING

**Depress the brake pedal immediately after the system stops the vehicle by automatic braking. Depending on the conditions of the road surface and tires, the vehicle**

**may not remain stopped, possibly leading to an unexpected accident.**

#### ▼ After the vehicle is stopped by the system

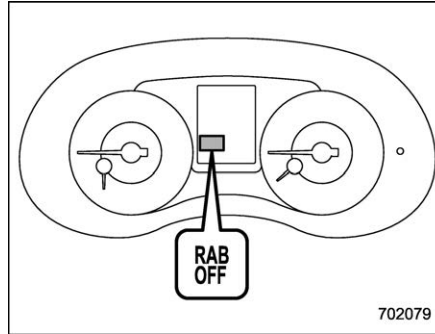

#### RAB OFF indicator

After the brake pedal is depressed, the RAB OFF indicator will illuminate and the system will stop operating temporarily. The RAB OFF indicator will turn off when the select lever is shifted to a position other than the "R" position.

The system will operate again the next time the select lever is shifted to "R" position.

In circumstances such as the following, the Reverse Automatic Braking (RAB) system automatically stops operating and the RAB

OFF indicator illuminates.

- There is ice, snow, mud, or other substance on the sonar sensors.
- The select lever was shifted to "R" when there is an obstacle located close to the rear bumper.
- A sound with a frequency close to that of the sonar used by the Reverse Automatic Braking (RAB) system was detected.

#### NOTE

● After the vehicle has been stopped by the Reverse Automatic Braking (RAB) system, brake control is released and the electronic parking brake operates in the following cases. For details about releasing the parking brake, refer to "Electronic parking brake (models with electronic parking brake system)" 7-42.

- 2 minutes pass after the vehicle is stopped.
- Any door is opened.
- The Reverse Automatic Braking (RAB) system may stop operating temporarily in the following cases and the RAB OFF indicator will illuminate.
  - Ice, snow or mud is adhered to the sonar sensors or the rear bumper near the sonar sensor.
  - Objects are too close to the rear

bumper when the select lever is set to the “R” position.

– The system detects sounds of a similar frequency to the RAB sonar.

### ■ Canceling the Reverse Automatic Braking (RAB) system operation

The Reverse Automatic Braking (RAB) system can be temporarily cancelled by any of the following operations.

- Depressing the brake pedal\*
- Depressing the accelerator pedal\*
- Depressing and holding the accelerator pedal (in this case, limited acceleration will be canceled and the vehicle will continue reversing.)
- Shifting the select lever to a position other than the “R” position

\*: While the vehicle is stopped by the automatic braking.

### NOTE

**The system will be cancelled if the object is no longer detected.**

### ■ Reverse Automatic Braking (RAB) system ON/OFF setting

While the select lever is shifted to the “R” position, the below functions of the Reverse Automatic Braking (RAB) system can be set by operating the multi-function display (color LCD).

For details about how to operate the multi-function display (color LCD), refer to “Basic operation” 3-46.

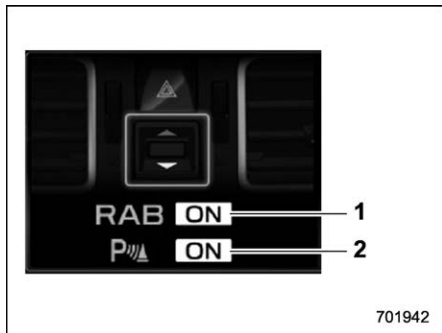

- 1) ON/OFF setting of Reverse Automatic Braking (RAB)
- 2) ON/OFF setting of the object detection warning sound

When the Reverse Automatic Braking (RAB) system is turned off, the RAB OFF indicator will illuminate.

### NOTE

The Reverse Automatic Braking (RAB) system settings that are changed by the multi-function display (color LCD) will be restored to default (ON setting) the next time the select lever is shifted to “R” position.

Also, the following settings can be changed by operating the combination meter display (color LCD).

- Warning volume
- Sonar audible alarm ON/OFF

For details, refer to “RAB (models with the EyeSight system)” 3-43.

## ■ RAB warning indicator

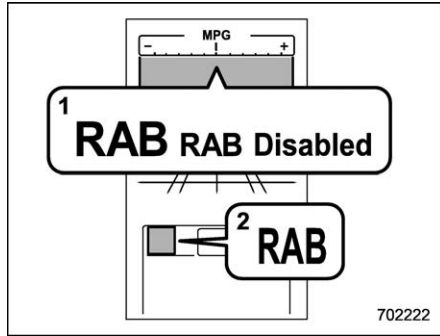

- 1) RAB malfunction message
- 2) RAB warning indicator

If the Reverse Automatic Braking (RAB) system malfunctions, the above indicator illuminates on the combination meter. Contact the nearest SUBARU dealer for details.

## ■ Handling of the sonar sensors

The 4 sonar sensors are located in the rear bumper. To ensure the proper operation of the Reverse Automatic Braking (RAB) system, observe the following precautions.

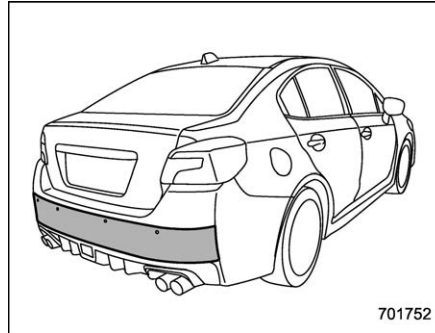

- Do not affix any stickers or other items on the sonar sensors or the bumper surface near the sonar sensors.
- Always keep the sonar sensors and the rear bumper surface near the sonar sensors clean.
- Do not modify the rear bumper.
- Do not paint the bumper near the sonar sensors.
- Do not apply strong impacts to the rear bumper near the sonar sensors. If a sensor

becomes misaligned, a system malfunction may occur, including inability to detect objects in the reversing direction. If any strong impact is applied to the rear bumper, contact a SUBARU dealer to have the system inspected.

- Do not disassemble the sonar sensors.

### NOTE

**If the sonar sensors require repair or replacement, or if the area of the rear bumper near the sonar sensors requires repair, paintwork or replacement, contact your SUBARU dealer for assistance.**

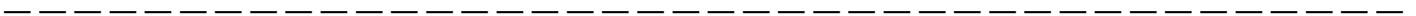
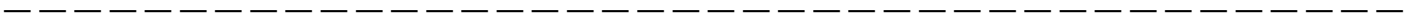
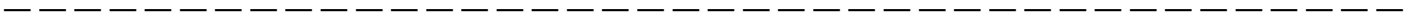
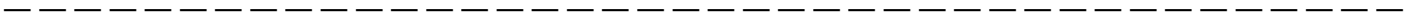
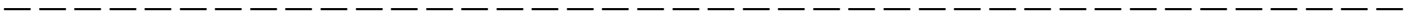
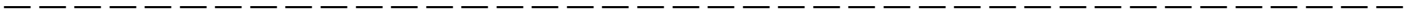
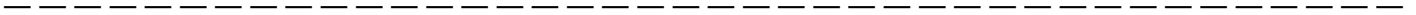
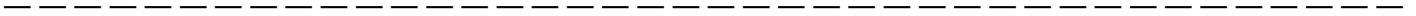
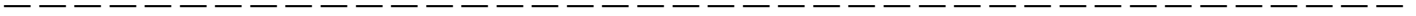

**New vehicle break-in driving – the first 1,000 miles (1,600 km)..... 8-2**  
**Fuel economy hints ..... 8-2**  
**Engine exhaust gas (carbon monoxide) ..... 8-2**  
**Catalytic converter..... 8-3**  
**Periodic inspections ..... 8-4**  
**Driving in foreign countries ..... 8-4**  
**Driving tips for AWD models ..... 8-5**  
**Driving precaution ..... 8-6**  
**Winter driving..... 8-6**  
    Operation during cold weather ..... 8-6

**Driving on snowy and icy roads..... 8-8**  
**Corrosion protection..... 8-9**  
**Snow tires ..... 8-9**  
**Tire chains ..... 8-10**  
**Rocking the vehicle ..... 8-10**  
**Loading your vehicle..... 8-10**  
    Vehicle capacity weight ..... 8-11  
    GVWR and GAWR (Gross Vehicle Weight Rating and Gross Axle Weight Rating) ..... 8-12  
    Roof molding and crossbar (if equipped) ..... 8-12  
**Trailer towing ..... 8-14**

## **New vehicle break-in driving – the first 1,000 miles (1,600 km)**

The performance and long life of your vehicle are dependent on how you handle and care for your vehicle while it is new. Follow these instructions during the first 1,000 miles (1,600 km):

- Do not race the engine. And do not allow engine speed to exceed 4,000 rpm except in an emergency.
- Do not drive at one constant engine or vehicle speed, either fast or slow.
- Avoid starting suddenly and rapid acceleration, except in an emergency.
- Avoid hard braking, except in an emergency.

The same break-in procedures should be applied to an overhauled engine, newly mounted engine or when brake pads or brake linings are replaced with new ones.

## **Fuel economy hints**

The following suggestions will help to save fuel.

- Select the proper gear position for the speed and road conditions.
- Avoid sudden acceleration or deceleration. Always accelerate gently until you reach the desired speed. Then try to maintain that speed for as long as possible.
- Do not pump the accelerator and avoid racing the engine.
- Avoid unnecessary engine idling.
- Keep the engine properly tuned.
- Keep the tires inflated to the correct pressure shown on the tire inflation pressure label, which is located under the door latch on the driver's side. Low pressure will increase tire wear and fuel consumption.
- Use the air conditioner only when necessary.
- Keep the front and rear wheels in proper alignment.
- Avoid carrying unnecessary luggage or cargo.
- The indication of the ECO gauge shows a reference for saving fuel. For details, refer to "ECO gauge" ☞ 3-12.

## **Engine exhaust gas (carbon monoxide)**



### **WARNING**

- **Never inhale engine exhaust gas. Engine exhaust gas contains carbon monoxide, a colorless and odorless gas which is dangerous, or even lethal, if inhaled.**
- **Always properly maintain the engine exhaust system to prevent engine exhaust gas from entering the vehicle.**
- **Never run the engine in a closed space, such as a garage, except for the brief time needed to drive the vehicle in or out of it.**
- **Avoid remaining in a parked vehicle for a lengthy time while the engine is running. If that is unavoidable, then use the ventilation fan to force fresh air into the vehicle.**
- **Always keep the front ventilator inlet grille free from snow, leaves or other obstructions to ensure that the ventilation system always works properly.**
- **If at any time you suspect that**



exhaust fumes are entering the vehicle, have the problem checked and corrected as soon as possible. If you must drive under these conditions, drive only with all windows fully open.

- Keep the trunk lid closed while driving to prevent exhaust gas from entering the vehicle.

## NOTE

Due to the expansion and contraction of the metals used in the manufacture of the exhaust system, you may hear a crackling sound coming from the exhaust system for a short time after the engine has been shut off. This sound is normal.

## Catalytic converter

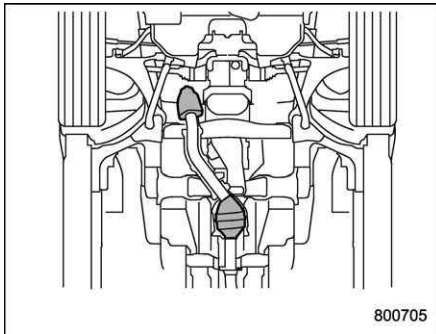

STI

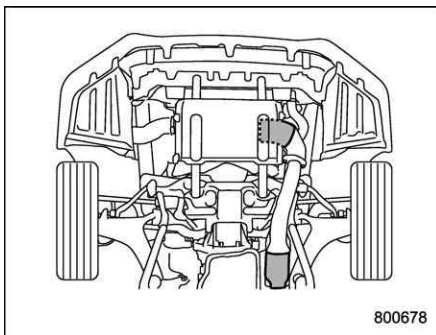

Except STI

The catalytic converter is installed in the exhaust system. It serves as a catalyst to

reduce HC, CO and NOx in exhaust gases, thus providing cleaner exhaust.

To avoid damage to the catalytic converter:

- Use only unleaded fuel. Even a small amount of leaded fuel will damage the catalytic converter.
- Never start the engine by pushing or pulling the vehicle.
- Avoid racing the engine.
- Never turn off the ignition switch while the vehicle is moving.
- Keep your engine tuned-up. If you feel the engine running rough (misfiring, back-firing or incomplete combustion), have your vehicle checked and repaired by an authorized SUBARU dealer.
- Do not apply undercoating or rust prevention treatment to the heat shield of catalytic converter and the exhaust system.
- Do not drive with an extremely low fuel level.



**WARNING**

- **Avoid fire hazards. Do not drive or park the vehicle anywhere near flammable materials (e.g., grass, paper, rags or leaves), because the catalytic converter operates at very high temperatures.**
- **Keep everyone and flammable materials away from the exhaust pipe while the engine is running. The exhaust gas is very hot.**

## **Periodic inspections**

To keep your vehicle in the best condition at all times, always have the recommended maintenance services listed in the maintenance schedule in the “Warranty and Maintenance Booklet” performed at the specified time or mileage intervals.

## **Driving in foreign countries**

When planning to use your vehicle in another country:

- Confirm the availability of the correct fuel. Refer to “Fuel requirements” ¶7-3.
- Comply with all regulations and requirements of each country.

## Driving tips for AWD models

### WARNING

- Always maintain a safe driving speed according to the road and weather conditions in order to avoid having an accident on a sharp turn, during sudden braking or under other similar conditions.
- Always use the utmost care in driving – overconfidence because you are driving an All-Wheel Drive vehicle could easily lead to a serious accident.
- When replacing or installing tire(s), all four tires must be the same for following items.
  - (a) Size
  - (b) Speed symbol
  - (c) Load index
  - (d) Circumference
  - (e) Construction
  - (f) Manufacturer
  - (g) Brand (tread pattern)
  - (h) Degrees of wear

For items (a) to (c), you must obey the specification that is

printed on the tire inflation pressure label. The tire inflation pressure label is located on the bottom of driver's door pillar.

If all four tires are not the same for items (a) to (h), serious mechanical damage could be caused to the drivetrain of the car, and affect the followings.

- Ride
- Handling
- Braking
- Speedometer/Odometer calibration
- Clearance between the body and tires

It also may be dangerous and lead to loss of vehicle control, and it can lead to an accident.

### CAUTION

**If you use a temporary spare tire to replace a flat tire, be sure to use the original temporary spare tire stored in the vehicle. Using other sizes may result in severe mechanical damage to the drive train of your vehicle.**

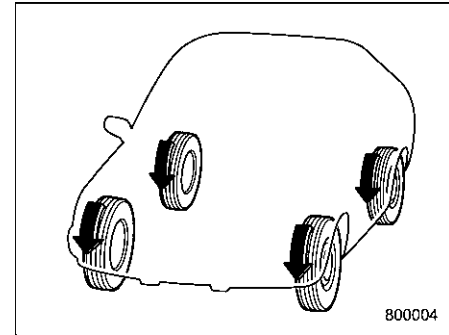

800004

All-Wheel Drive distributes the engine power to all four wheels. AWD models provide better traction when driving on slippery, wet or snow-covered roads and when moving out of mud, dirt and sand. By shifting power between the front and rear wheels, SUBARU AWD can also provide added traction during acceleration and added engine braking force during deceleration.

Therefore, your SUBARU AWD vehicle may handle differently than an ordinary two wheel drive vehicle and it contains some features unique to AWD. For safety purposes as well as to avoid damaging the AWD system, you should keep the following tips in mind.

- An AWD model is better able to climb steeper roads under snowy or slippery

– CONTINUED –

conditions than a two wheel drive vehicle. There is little difference in handling, however, during extremely sharp turns or sudden braking. Therefore, when driving down a slope or turning corners, be sure to reduce your speed and maintain an ample distance from other vehicles.

- Always check the cold tire pressure before starting to drive. The recommended tire pressure is provided on the tire inflation pressure label, which is located under the door latch on the driver's side.
- Frequent driving of an AWD vehicle under hard-driving conditions such as steep hills or dusty roads will necessitate more frequent replacement of the following items than that specified in the "Warranty and Maintenance Booklet".
  - Engine oil
  - Brake fluid
  - Rear differential gear oil
  - Manual transmission oil (MT models)
  - Continuously variable transmission fluid (CVT models)
  - Front differential gear oil (CVT models)
- There are some precautions that you must observe when towing your vehicle. For detailed information, refer to "Towing" ☞9-13.

## **Driving precaution**

Water entering the engine air intake or the exhaust pipe or water splashing onto electrical parts may damage your vehicle and may cause it to stall. Never attempt to drive through rushing water; regardless of its depth, it can wash away the ground from under your tires, resulting in possible loss of traction and even vehicle rollover.

## **Winter driving**

### **■ Operation during cold weather**

Carry some emergency equipment, such as a window scraper, a bag of sand, flares, a small shovel and jumper cables.

Check the battery and cables. Cold temperatures reduce battery capacity. The battery must be in good condition to provide enough power for cold winter starts.

It normally takes longer to start the engine in very cold weather conditions. Use an engine oil of a proper grade and viscosity for cold weather. Using heavy summer oil will make it harder to start the engine.

Keep the door locks from freezing by squirting them with deicer or glycerin.

Forcing a frozen door open may damage or separate the rubber weather strips around the door. If the door is frozen, use hot water to melt the ice, and afterwards thoroughly wipe the water away.

Use a windshield washer fluid that contains an antifreeze solution. Do not use engine antifreeze or other substitutes because they may damage the paint of the vehicle.

If you fill the reservoir tank with a fluid with a different concentration from the one used previously, purge the old fluid from the piping between the reservoir tank and washer nozzles by operating the washer for a certain period of time. Otherwise, if the concentration of the fluid remaining in the piping is too low for the outside temperature, it may freeze and block the nozzles.

 **CAUTION**

- **Adjust the washer fluid concentration appropriately for the outside temperature. If the concentration is inappropriate, sprayed washer fluid may freeze on the windshield and obstruct your view, and the fluid may freeze in the reservoir tank.**
- **Be careful foreign matter does not contaminate the washer fluid when filling the tank. Contamination could cause malfunctions, such as clogging the pump.**
- **State or local regulations on volatile organic compounds may restrict the use of methanol, a common windshield washer anti-freeze additive. Washer fluids containing non-methanol anti-**

**freeze agents should be used only if they provide cold weather protection without damaging your vehicle's paint, wiper blades or washer system.**

▼ **Before driving your vehicle**

Before entering the vehicle, remove any snow or ice from your shoes because that could make the pedals slippery and driving dangerous.

While warming up the vehicle before driving, check that the accelerator pedal, brake pedal, and all other controls operate smoothly.

Clear away ice and snow that has accumulated under the fenders to avoid making steering difficult. During severe winter driving, stop when and where it is safe to do so and check under the fenders periodically.

▼ **Parking in cold weather**

 **WARNING**

**Snow can trap dangerous exhaust gases under your vehicle. Keep snow clear of the exhaust pipe and from around your vehicle if you park the vehicle in snow with the engine**

running.

 **CAUTION**

- **Do not use the parking brake when parking for long periods in cold weather since it could freeze in that position.**
- **When you park the vehicle in snow or when it snows, raise the wiper blades off the glass to prevent damage.**
- **Under either of the following conditions, ice may form on the brake system, which could cause poor braking action.**
  - **When the vehicle has been left parked after use on roads heavily covered with snow**
  - **When the vehicle has been left parked during a snowstorm**

**Check for snow or ice buildup on the suspension, disc brakes and brake hoses underneath the vehicle. If there is caked snow or ice, remove it, being careful not to damage the disc brakes and brake hoses and ABS harness.**

When parking for long periods in cold

weather, you should observe the following tips.

1. For MT models, place the shift lever in the “1” or “R” position. For CVT models, place the select lever in the “P” position.
2. Use tire stops under the tires to prevent the vehicle from moving.

### ▼ Refueling in cold weather

To help prevent moisture from forming in the fuel system and the risk of its freezing, use of an antifreeze additive in the fuel tank is recommended during cold weather. Use only additives that are specifically designed for this purpose. When an antifreeze additive is used, its effect lasts longer if the tank is refilled whenever the fuel level reaches half empty.

If your SUBARU is not going to be used for an extended period, it is best to have the fuel tank filled to capacity.

### ■ Driving on snowy and icy roads

To prevent skidding and slipping, avoid sudden braking, abrupt acceleration, high-speed driving, and sharp turning when driving on snowy or icy roads.

Always maintain ample distance between your vehicle and the vehicle ahead of you to avoid the need for sudden braking.

To supplement the foot brake, use the engine brake effectively to control the vehicle speed. (Shift into a lower gear when necessary.)

Avoid shifting down abruptly. Such behavior can cause the wheels to lock, possibly leading to loss of vehicle control.

An anti-lock brake system (ABS) enhances your vehicle’s braking performance on snowy and icy roads. For information on braking on slippery surfaces, refer to “ABS (Anti-lock Brake System)” 7-34 and “Vehicle Dynamics Control system” 7-37.

#### **WARNING**

**Do not use the cruise control on slippery roads such as snowy or icy roads. This may cause loss of vehicle control.**

#### **CAUTION**

**Avoid prolonged continuous driving in snowstorms. Snow will enter the engine’s intake system and may hinder the airflow, which could result in engine shutdown or even breakdown.**

### ▼ Wiper operation when snowing

Before driving in cold weather, make sure the wiper blade rubbers are not frozen to the windshield.

If the wiper blade rubbers are frozen to the windshield, use the defroster and the temperature set for maximum warmth until the wiper blade rubbers are completely thawed. Refer to “Climate control” 4-1.

If your vehicle is equipped with a wiper deicer, use it. It is helpful to thaw the windshield wiper blade rubbers. Refer to “Defogger and deicer” 3-86.

When driving in snow, if frozen snow starts to stick on the surface of the windshield despite wiper operation, use the defroster and the temperature set for maximum warmth. After the windshield gets warmed enough to melt the frozen snow on it, wash it away using the windshield washer. Refer to “Windshield washer” 3-76.

Snow stuck on the wiper arm prevents the wiper from working effectively. If snow is stuck on the wiper arm, pull off the road to a safe place, then remove it. If you stop the vehicle at road side, use the hazard warning flasher to alert other drivers. Refer to “Hazard warning flasher” 3-8.

We recommend use of non-freezing type wiper blades (winter blades) during the seasons you could have snow and freezing temperatures. Blades of this type give superior wiping performance in snowy conditions. Be sure to use blades that are suitable for your vehicle.



### CAUTION

**During high-speed driving, non-freezing type wiper blades may not perform as well as standard wiper blades. If this happens, reduce the vehicle speed.**

### NOTE

When the season requiring non-freezing type wiper blades is over, replace them with standard wiper blades.

### ■ Corrosion protection

Refer to “Corrosion protection” 10-4.

### ■ Snow tires



### WARNING

- When replacing or installing winter tire(s), all four tires must be the same for following items.

- (a) Size
- (b) Speed symbol
- (c) Load index
- (d) Circumference
- (e) Construction
- (f) Manufacturer
- (g) Brand (tread pattern)
- (h) Degrees of wear

For items (a) to (c), you must obey the specification that is printed on the tire inflation pressure label. The tire inflation pressure label is located on the bottom of driver’s door pillar.

If all four tires are not the same for items (a) to (h), serious mechanical damage could be caused to the drivetrain of the car, and affect the followings.

- Ride
- Handling
- Braking
- Speedometer/Odometer calibration
- Clearance between the body and tires

It also may be dangerous and lead to loss of vehicle control,

and it can lead to an accident.

- Do not use a combination of radial, belted bias or bias tires since it may cause dangerous handling characteristics and lead to an accident.

Your vehicle is equipped with “summer tires” as original equipment, which are inadequate for driving on slippery roads such as on snow-covered or icy roads.

When you choose to install winter tires on your vehicle, be sure to use the correct tire size and type. You must install four winter tires that are of the same size, construction, brand and load range and you should never mix radial, belted bias or bias tires since this may result in dangerous handling characteristics. When you choose a tire, make sure that there is enough clearance between the tire and vehicle body.

Remember to drive with care at all times regardless of the type of tires on your vehicle.

## ■ Tire chains



**CAUTION**

You cannot use tire chains on your vehicle because of the lack of clearance between the tires and vehicle body.

## NOTE

Even though you cannot use tire chains, use of another type of traction device (such as spring chains) may be acceptable if use on your vehicle is recommended by the device manufacturer, taking into account tire size and road conditions. Follow the device manufacturer's instructions, especially regarding maximum vehicle speed.

To help avoid damage to your vehicle, drive slowly, readjust or remove the device if it is contacting your vehicle, and do not spin your wheels. Damage caused to your vehicle by use of a traction device is not covered under warranty.

Make certain that any traction device you use is an SAE class S device, and use it on the front wheels only. Always use the utmost care when driving with a traction device. Overconfidence be-

cause you are using a traction device could easily lead to a serious accident.

## ■ Rocking the vehicle

If you must rock the vehicle to free it from snow, sand, or mud, depress the accelerator pedal slightly and move the shift lever/select lever back and forth between "1"/"D" and "R" repeatedly. Do not race the engine. For the best possible traction, avoid spinning the wheels when trying to free the vehicle.

When the road surface is extremely slippery, you can obtain better traction by starting the vehicle with the transmission in 2nd than in 1st (MT models and CVT models).

If your vehicle is a CVT model, for information about holding the transmission in the 2nd position, refer to "Selection of manual mode" 7-25.

## Loading your vehicle

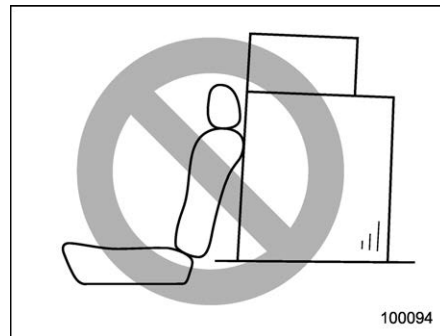

**WARNING**

- Never allow passengers to ride on a folded rear seatback or in the trunk. Doing so may result in serious injury.
- Never stack luggage or other cargo higher than the top of the seatback because it could tumble forward and injure passengers in the event of a sudden stop or accident. Keep luggage or cargo low, as close to the floor as possible.
- Stow cargo and luggage in the trunk whenever possible.



- To prevent cargo and luggage from sliding forward during braking, do not stack anything in the enlarged trunk. Keep cargo and luggage low, as close to the floor as possible.
- When you carry something inside the vehicle, secure it whenever you can to prevent it from being thrown around inside the vehicle during sudden stops, sharp turns or in an accident.
- Do not pile heavy loads on the roof. These loads raise the vehicle's center of gravity and make it more prone to tip over.
- Secure lengthy items properly to prevent them from shooting forward and causing serious injury during a sudden stop.
- Never exceed the maximum load limit. If you do, some parts on your vehicle can break, or it can change the way your vehicle handles. This could result in loss of control and cause personal injury. Also, overloading can shorten the life of your vehicle.
- Do not place cargo or luggage in or on the following locations as the item may get under the

clutch, brake, or accelerator pedal and prevent the pedals from being depressed properly, block the driver's vision, or hit the driver or passengers, causing an accident:

- At the feet of the driver
- On the front passenger or rear seats (when stacking items)
- On the rear shelf
- On the instrument panel
- On the dashboard



### CAUTION

Do not carry spray cans, containers with flammable or corrosive liquids or any other dangerous items inside the vehicle.

### NOTE

For better fuel economy, do not carry unneeded cargo.

## ■ Vehicle capacity weight

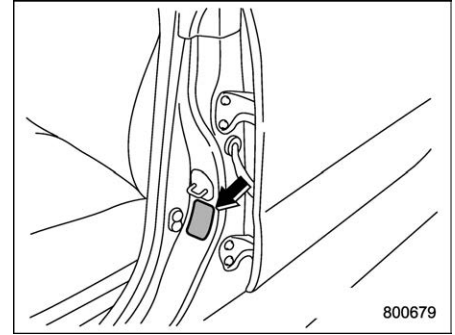

Vehicle placard

The load capacity of your vehicle is determined by weight, not by available cargo space. The maximum load you can carry in your vehicle is shown on the vehicle placard attached to the driver's side door pillar. It includes the total weight of the driver and all passengers and their belongings, any optional equipment such as a roof rack or bike carrier, etc.

## ■ GVWR and GAWR (Gross Vehicle Weight Rating and Gross Axle Weight Rating)

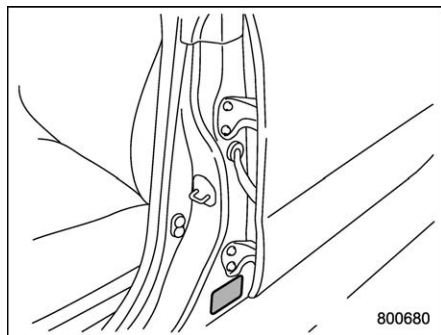

### Certification label

The certification label attached to the driver's side doorjamb shows GVWR (Gross Vehicle Weight Rating) and GAWR (Gross Axle Weight Rating).

The GVW (Gross Vehicle Weight) must never exceed the GVWR. GVW is the combined total of weight of the vehicle, fuel, driver, all passengers, luggage, and any optional equipment. Therefore, the GVW changes depending on the situation. The GVWR equals Curb Weight (actual weight of your vehicle – including standard equipment, fluids, emergency tools and spare tire assembly) plus the vehicle

capacity weight.

In addition, the total weight applied to each axle (GAW) must never exceed the GAWR. The front and rear GAWs can be adjusted by relocating luggage inside the vehicle.

Even if the total weight of your luggage is lower than the vehicle capacity weight, either front or rear GAW may exceed the GAWR, depending on the distribution of the luggage.

When possible, the load should be evenly distributed throughout the vehicle.

If you carry heavy loads in the vehicle, you should confirm that GVW and front and rear GAWs are within the GVWR and GAWR by putting your vehicle on a vehicle scale, found at a commercial weighing station.

Do not use replacement tires with a lower load range than the originals because they may lower the GVWR and GAWR limitations. Replacement tires with a higher load range than the originals do not increase the GVWR and GAWR limitations.

## ■ Roof molding and crossbar (if equipped)

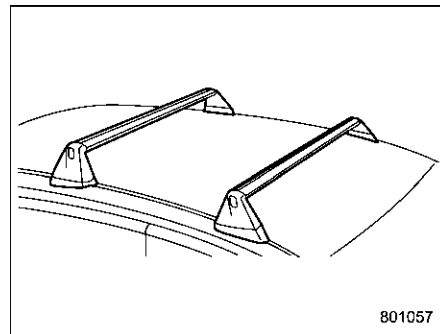

### CAUTION

- For cargo carrying purposes, the roof molding must be used together with a roof crossbar kit and the appropriate carrying attachment. Otherwise, damage to the roof or paint or a dangerous road hazard due to loss of cargo could result.
- When using the roof crossbar kit, make sure that the total weight of the crossbars, carrying attachment and cargo does not exceed the maximum load limit. Overloading may cause damage to

**the vehicle and create a safety hazard.**

Cargo can be carried after securing the roof crossbar kit to the roof molding and installing the appropriate carrying attachment. When installing the roof crossbar kit, follow the manufacturer's instructions.

When carrying cargo on the roof using the roof crossbar kit and carrying attachments, never exceed the maximum load limit as explained below. You should also be careful that the vehicle does not exceed the Gross Vehicle Weight Rating (GVWR) and front and rear Gross Axle Weight Rating (GAWR). For information about loading cargo into or onto your vehicle, refer to "Loading your vehicle" 8-10. The maximum total load on the roof (including crossbars, carrying attachments and cargo) must not exceed **88 lbs (40 kg)**. Refer to the crossbar installation instructions for the maximum crossbar capacity. Place the heaviest load at the bottom, close to the roof, and evenly distribute the cargo. Always properly secure all cargo.

▼ **Installing carrying attachments on the crossbars**

When installing any carrying attachments such as the load carriers, crossbars, bike carrier, ski carrier, kayak carrier, cargo

basket, etc., follow the manufacturer's instructions of the load capacity and make sure that the attachments are securely installed. Use only attachments designed specifically for the crossbars. Before operating the vehicle, make sure that the cargo is properly secured on the attachment.

**NOTE**

**Remember that the vehicle's center of gravity is altered with the weight of the load on the roof, thus affecting the driving characteristics.**

**Drive carefully. Avoid rapid starts, hard cornering and abrupt stops. Crosswind effects will be increased.**

▼ **Removal and installation of the crossbars**

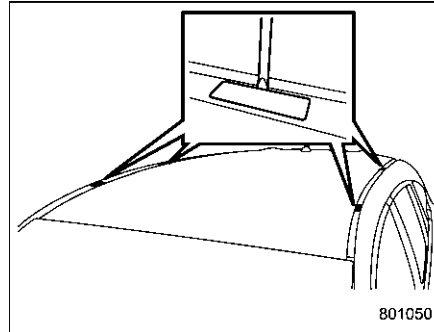

Each of the two roof moldings has two mounting points for crossbars. Each mounting point is fitted with a cover. Use a screwdriver to remove the covers. When installing the crossbars on the roof molding, follow the manufacturer's instructions.

## **Trailer towing**

---



### **CAUTION**

**Your vehicle is neither designed nor intended to be used for trailer towing. Therefore, never tow a trailer with your vehicle.**

SUBARU assumes no responsibility for injuries or vehicle damage that may result from trailer towing, from any trailer towing equipment or from any errors or omissions in the instructions accompanying such equipment. SUBARU warranties do not apply to vehicle damage or malfunction caused by trailer towing.

## *In case of emergency*

<b>If you park your vehicle in case of an emergency</b> .....	9-2
<b>Temporary spare tire</b> .....	9-2
<b>Maintenance tools</b> .....	9-3
<b>Flat tires</b> .....	9-4
Changing a flat tire .....	9-4
Tire pressure monitoring system (TPMS) (U.S.-spec. models) .....	9-8
<b>Jump starting</b> .....	9-9
How to jump start .....	9-10
<b>Engine overheating</b> .....	9-12
If steam is coming from the engine compartment .....	9-12
If no steam is coming from the engine compartment .....	9-12

<b>Towing</b> .....	9-13
Towing and tie-down hooks/holes .....	9-13
Using a flat-bed truck .....	9-16
Towing with all wheels on the ground .....	9-17
<b>Electronic parking brake – if the electronic parking brake cannot be released (models with electronic parking brake system)</b> .....	9-18
<b>Access key fob – if access key fob does not operate properly</b> .....	9-18
Locking and unlocking .....	9-18
Switching power status .....	9-19
Starting engine .....	9-19
<b>Moonroof (if equipped) – if the moonroof does not close</b> .....	9-20
<b>If your vehicle is involved in an accident</b> .....	9-20

## If you park your vehicle in case of an emergency

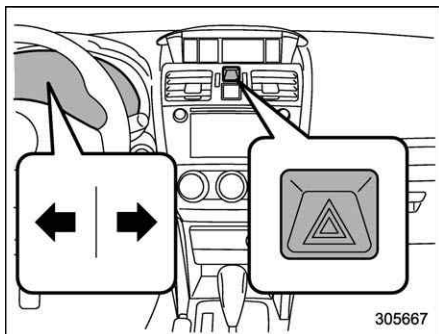

Use the hazard warning flasher in day or night to warn other drivers when you have to park your vehicle under emergency conditions.

Avoid stopping on the road. It is best to safely pull off the road if a problem occurs.

You can activate the hazard warning flasher regardless of the ignition switch position.

Turn on the hazard warning by pushing the hazard warning flasher switch. Turn it off by pushing the switch again.

### NOTE

When the hazard warning flasher is on, the turn signals do not work.

## Temporary spare tire

### WARNING

When a spare tire is mounted or a wheel rim is replaced without the original pressure sensor/transmitter being transferred, the low tire pressure warning light will illuminate steadily after blinking for approximately one minute. This indicates the tire pressure monitoring system (TPMS) is unable to monitor all four road wheels. Contact your SUBARU dealer as soon as possible for tire and sensor replacement and/or system resetting.

### CAUTION

- Never use any temporary spare tire other than the original. Using other sizes may result in severe mechanical damage to the drive train of your vehicle.
- Always conform to the following instructions when using the temporary spare tire. Otherwise, a seriously dangerous situation may occur.

The temporary spare tire is smaller and lighter than a conventional tire and is designed for emergency use only. Remove the temporary spare tire and re-install the conventional tire as soon as possible because the spare tire is designed only for temporary use.

Check the inflation pressure of the temporary spare tire periodically to keep the tire ready for use. For the correct tire pressure, refer to “Temporary spare tires” 12-9.

When using the temporary spare tire, note the following.

- Drive with caution when temporary spare tire is fitted. Avoid hard acceleration and braking, or fast cornering, as control of the vehicle may be lost.
- Do not exceed 50 mph (80 km/h).
- Do not put a tire chain on the temporary spare tire. Because of the smaller tire size, a tire chain will not fit properly.
- Do not use two or more temporary spare tires at the same time.
- Do not drive over obstacles. This tire has a smaller diameter, so road clearance is reduced.

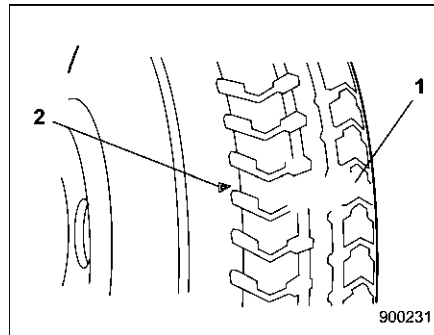

- 1) Tread wear indicator bar
- 2) Indicator location mark

- When the wear indicator appears on the tread, replace the tire.
- The temporary spare tire must be used only on a rear wheel. If a front wheel tire gets punctured, replace the wheel with a rear wheel and install the temporary spare tire in place of the removed rear wheel.
- Always set the driver's control center differential to the manual mode and adjust the initial LSD torque to the minimum.

## Maintenance tools

Your vehicle is equipped with the following maintenance tools.

- Jack
- Jack handle
- Screwdriver
- Towing hook (eye bolt)
- Wheel nut wrench

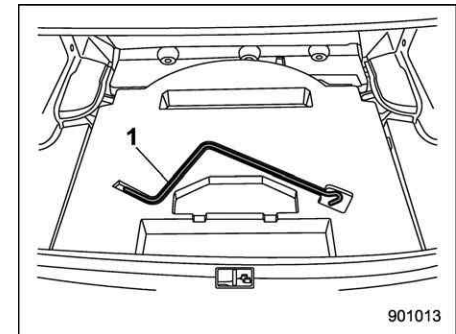

- 1) Jack handle

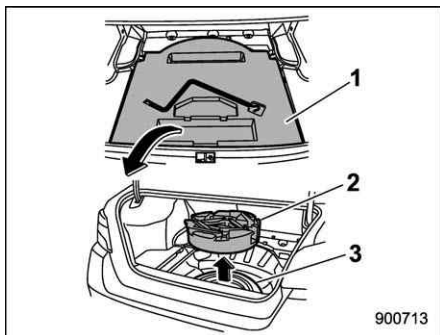

- 1) Under-floor storage compartment (if equipped) (Refer to “Under-floor storage compartment” 6-13.)
- 2) Tool bucket
- 3) Spare tire

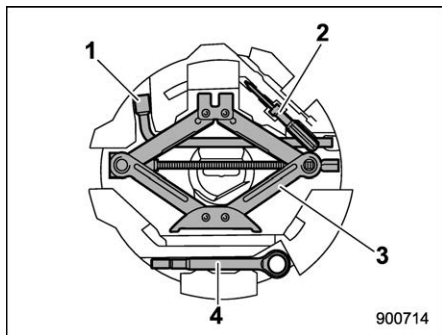

- 1) Wheel nut wrench
- 2) Screwdriver
- 3) Jack
- 4) Towing hook (eye bolt)

A jack handle is stored under the floor of the trunk. Other tools are stored in the tool bucket that is located in the recess of the spare tire wheel.

### NOTE

For how to use the jack, refer to “Flat tires” 9-4.

## Flat tires

If you have a flat tire while driving, never brake suddenly; keep driving straight ahead while gradually reducing speed. Then slowly pull off the road to a safe place.

### ■ Changing a flat tire

#### WARNING

- Use only the jack and the jack handle provided with your vehicle. The jack supplied with the vehicle is designed only for changing a tire. Never get under the vehicle while supporting the vehicle with this jack.
- Do not jack up the vehicle on an incline or a loose road surface. The jack can come out of the jacking point or sink into the ground and this can result in a severe accident.
- Do not jack up the vehicle with an object on or underneath the jack. The jack can be unstable and this can result in a severe accident.
- Before using the jack, be sure that there are no occupants or



cargo in the vehicle.

- Always turn off the engine before raising the flat tire off the ground using the jack. Never swing or push the vehicle supported with the jack. The jack can come out of the jacking point due to a jolt and this can result in a severe accident.

**CAUTION**

Do not hit and bend the disc rotor backing plate when removing and installing the tire. A bent backing plate may scrape against the disc rotor and cause noise while the vehicle is in motion.

**NOTE**

Contact a SUBARU dealer when jacking up the vehicle using a garage jack.

1. Park on a hard, level surface, whenever possible, then stop the engine.
2. Set the parking brake securely and shift the shift lever in reverse (MT models) or the select lever to the "P" (Park) position (CVT models).
3. Turn on the hazard warning flasher and unload all occupants and luggage from the

vehicle.

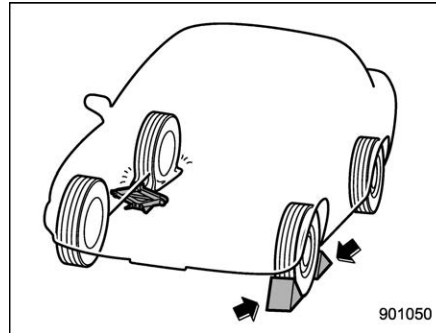

4. Put wheel blocks at the front and rear of the tire diagonally opposite the flat tire.
5. Take out the jack, jack handle and wheel nut wrench.

The tools and the spare tire are stored under the floor of the trunk. Refer to "Maintenance tools" 9-3.

**NOTE**

Make sure that the jack is well lubricated before using it.

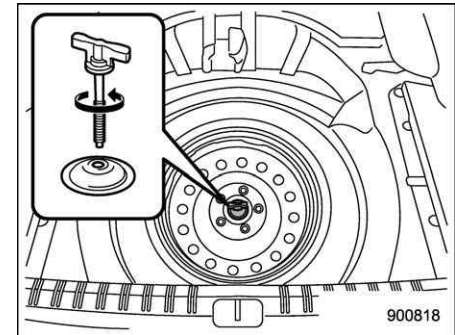

6. Take out the tool bucket and turn the attaching bolt counterclockwise, then take the spare tire out.

**NOTE**

If the spare tire provided in your vehicle is a temporary spare tire, carefully read "Temporary spare tire" 9-2 and strictly follow the instructions.

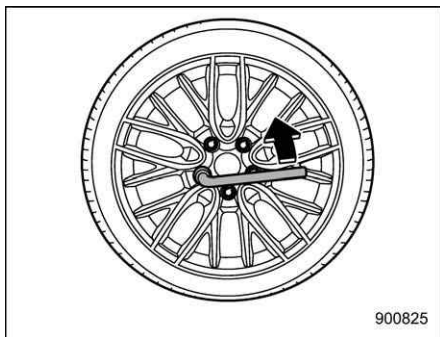

7. Loosen the wheel nuts using the wheel nut wrench but do not remove the nuts.

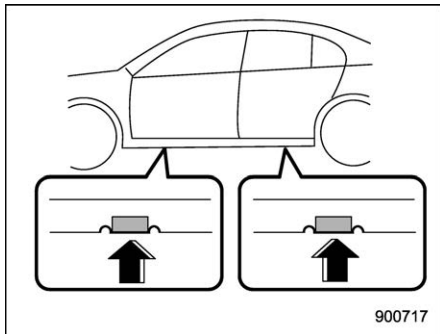

**Jack-up points**

8. Place the jack under the side sill at the front or rear jack-up point closest to the flat tire.

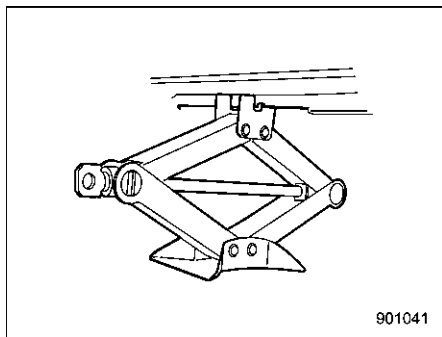

Turn the jackscrew by hand until the jack head engages firmly into the jack-up point.

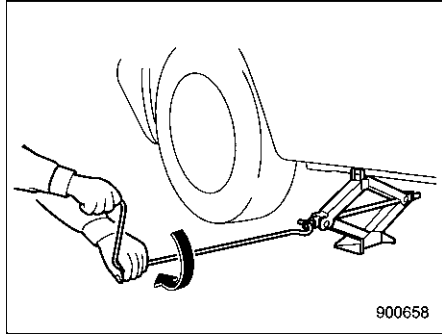

9. Insert the jack handle into the jackscrew, and turn the handle until the tire clears the ground. Do not raise the vehicle higher than necessary.

10. Remove the wheel nuts and the flat tire.

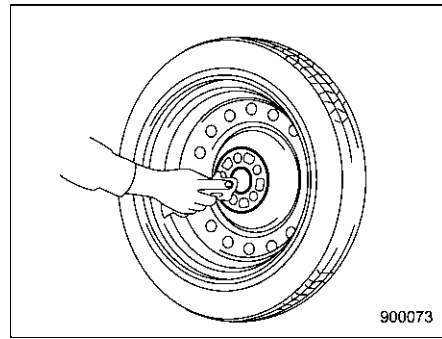
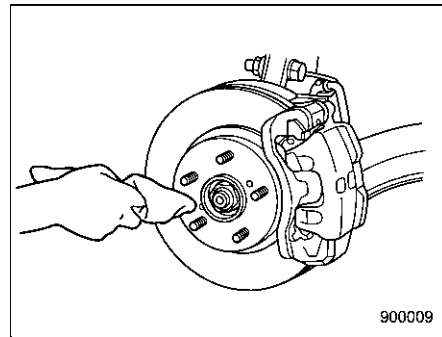

11. Before putting the spare tire on, perform the following steps.

- Clean the mounting surface of the wheel and hub with a cloth.

- Clean the threaded parts with a cloth and check the conditions there.

**CAUTION**

If the threaded part was damaged, you should immediately contact your SUBARU dealer.

12. Put on the spare tire. Replace the wheel nuts. Tighten them by hand.

**WARNING**

Do not use oil or grease on the wheel studs or nuts when the spare tire is installed. This could cause the nuts to become loose and lead to an accident.

13. Turn the jack handle counterclockwise to lower the vehicle.

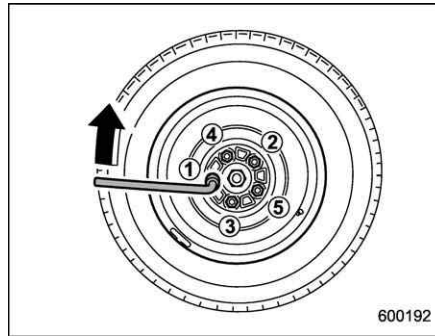

14. Use the wheel nut wrench to securely tighten the wheel nuts to the specified torque, following the tightening order in the illustration.

For the wheel nut tightening torque, refer to "Tires" 12-8. Never use your foot on the wheel nut wrench or a pipe extension on the wrench because you may exceed the specified torque. Have the wheel nut torque checked at the nearest automotive service facility.

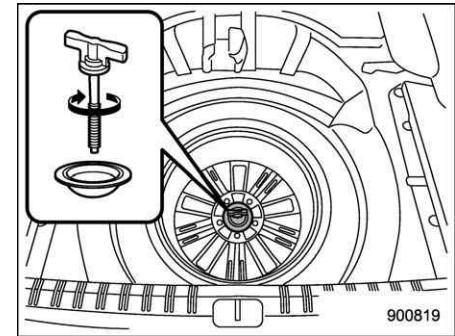

**Except STI**

15. Store the flat tire in the spare tire compartment. For except STI models, put in the spacer and tighten the attaching bolt firmly.

Also store the jack, jack handle and wheel nut wrench in their storage locations.

**WARNING**

- Never place a tire or tire changing tools in the passenger compartment after changing wheels. In a sudden stop or collision, loose equipment could strike occupants and cause injury. Store the tire and all tools in the proper place.

- When you store a flat tire, be sure to set the rear seatback to the upright position. If you fold down the seatback, an accident or injury may occur when the flat tire suddenly moves.

### ■ Tire pressure monitoring system (TPMS) (U.S.-spec. models)

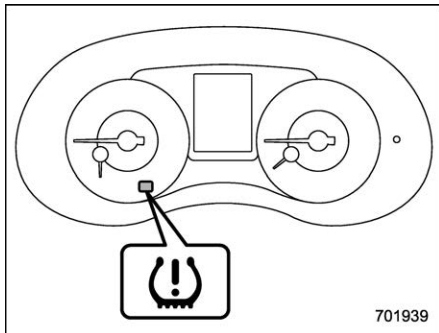

Low tire pressure warning light

The tire pressure monitoring system provides the driver with the warning message indicated by sending a signal from a sensor that is installed in each wheel when tire pressure is severely low.

The tire pressure monitoring system will activate only when the vehicle is driven.

Also, this system may not react immediately to a sudden drop in tire pressure (for example, a blow-out caused by running over a sharp object).

### WARNING

- If the low tire pressure warning light illuminates while driving, never brake suddenly. Instead, perform the following procedure.

- (1) Keep driving straight ahead while gradually reducing speed.
- (2) Slowly pull off the road to a safe place. Otherwise an accident involving serious vehicle damage and serious personal injury could occur.
- (3) Check the pressure for all four tires and adjust the pressure to the COLD tire pressure shown on the tire inflation pressure label on the door pillar on the driver's side.

If this light still illuminates while driving after adjusting the tire pressure, a tire may have significant damage and a fast leak that causes the tire to lose air rapidly. If you have a flat tire, refer to "Flat tires" 9-4.

- When a spare tire is mounted or a wheel rim is replaced without the original pressure sensor/transmitter being transferred, the low tire pressure warning light will illuminate steadily after blinking for approximately one minute. This indicates the TPMS is unable to monitor all four road wheels. Contact your SUBARU dealer as soon as possible for tire and sensor replacement and/or system resetting.
- When a tire is repaired with liquid sealant, the tire pressure warning valve and transmitter may not operate properly. If a liquid sealant is used, contact your nearest SUBARU dealer or other qualified service shop as soon as possible. Make sure to replace the tire pressure warning valve and transmitter when replacing the tire. You may reuse the wheel if there is no damage to it and if the sealant residue is properly cleaned off.

If the light illuminates steadily after blinking for approximately one minute, promptly contact a SUBARU dealer to have the system inspected.

## Jump starting

### WARNING

- **Battery fluid is SULFURIC ACID.** Do not let it come in contact with the eyes, skin, clothing or the vehicle.  
If battery fluid gets on you, thoroughly flush the exposed area with water immediately. Get medical help if the fluid has entered your eyes.  
If battery fluid is accidentally swallowed, immediately drink a large amount of milk or water, and obtain immediate medical help.  
Keep everyone including children away from the battery.
- **The gas generated by a battery explodes if a flame or spark is brought near it. Do not smoke or light a match while jump starting.**
- **Never attempt jump starting if the discharged battery is frozen. It could cause the battery to burst or explode.**
- **Whenever working on or around a battery, always wear suitable eye**

protectors, and remove metal objects such as rings, bands or other metal jewelry.

- **Be sure the jumper cables and clamps on them do not have loose or missing insulation.**  
Do not jump start unless cables in suitable condition are available.
- **A running engine can be dangerous. Keep your fingers, hands, clothing, hair and tools away from the cooling fan, belts and any other moving engine parts. Removing rings, watches and ties is advisable.**
- **Jump starting is dangerous if it done incorrectly. If you are unsure about the proper procedure for jump starting, consult a competent mechanic.**

When your vehicle does not start due to a run down (discharged) battery, the vehicle may be jump started by connecting your battery to another battery (called the booster battery) with jumper cables.

■ **How to jump start**

1. Make sure the booster battery is 12 volts and the negative terminal is grounded.
2. If the booster battery is in another vehicle, do not let the two vehicles touch.
3. Turn off all unnecessary lights and accessories.
4. Connect the jumper cables exactly in the sequence illustrated.

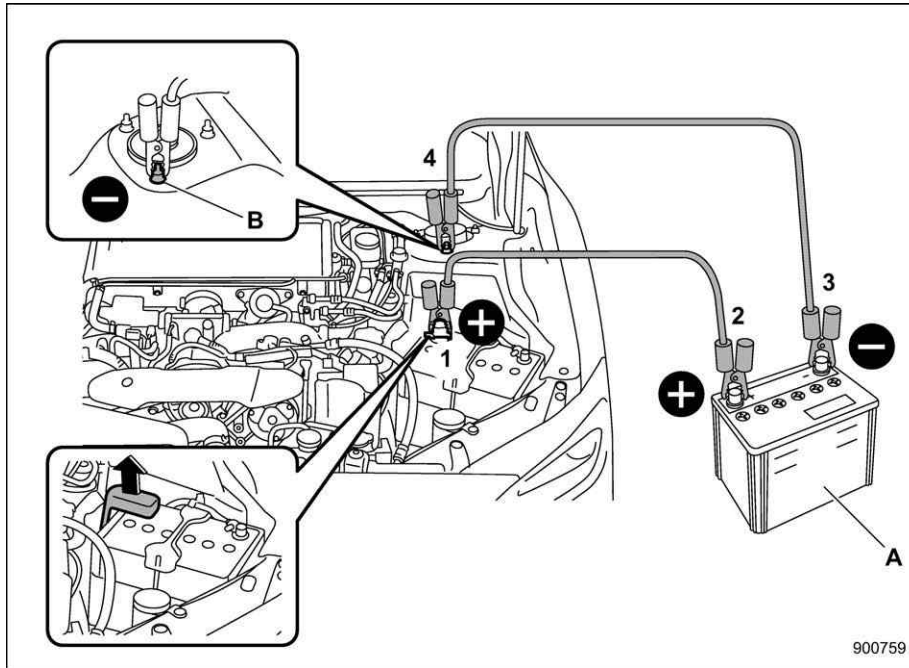

- A) Booster battery
- B) Strut mounting nut

- (1) Connect one jumper cable to the positive (+) terminal on the discharged battery.
- (2) Connect the other end of the jumper cable to the positive (+) terminal of the booster battery.
- (3) Connect one end of the other cable to the negative (-) terminal of the booster battery.
- (4) Connect the other end of the cable to the strut mounting nut of the vehicle with the discharged battery.

Make sure that the cables are not near any moving parts and that the cable clamps are not in contact with any other metal.

5. Start the engine of the vehicle with the booster battery and run it at moderate speed. Then start the engine of the vehicle that has the discharged battery.
6. When finished, carefully disconnect the cables in exactly the reverse order.

## Engine overheating

**⚠ WARNING**

Never remove the radiator cap until the engine has been shut off and has fully cooled down. When the engine is hot, the coolant is under pressure. Removing the cap while the engine is still hot could release a spray of boiling hot coolant, which could burn you very seriously.

If the engine overheats, safely pull off the road and stop the vehicle in a safe location.

### ■ If steam is coming from the engine compartment

- Turn off the engine and get everyone away from the vehicle until it cools down.
- Contact an authorized SUBARU dealer.

### ■ If no steam is coming from the engine compartment

1. Keep the engine running at idling speed.
2. Open the engine hood to ventilate the engine compartment. Refer to “Engine hood” ☞ 11-9.  
Confirm that the cooling fan is turning. If the fan is not turning, immediately turn off the engine and contact an authorized SUBARU dealer for repair.
3. After the engine coolant temperature has dropped, turn off the engine.

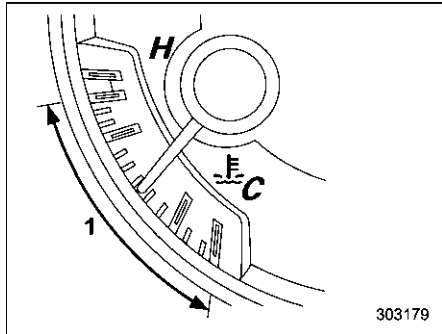

#### Temperature gauge

- 1) Normal operating range

If temperature gauge stays in the overheated zone, turn off the engine. Refer to “Temperature gauge” ☞ 3-11.

4. After the engine has fully cooled down, check the coolant level in the reserve tank. If the coolant level is below the “LOW” mark, add coolant up to the “FULL” mark.

### NOTE

For details about how to check the coolant level or how to add coolant, refer to “Engine coolant” ☞ 11-17.

5. If there is no coolant in the reserve tank, add coolant to the reserve tank. Then remove the radiator cap and fill the radiator with coolant.

If you remove the radiator cap from a hot radiator, first wrap a thick cloth around the radiator cap, then turn the cap counter-clockwise slowly without pressing down until it stops. Release the pressure from the radiator. After the pressure has been fully released, remove the cap by pressing down and turning it.



## Towing

If towing is necessary, it is best done by your SUBARU dealer or a commercial towing service. Observe the following procedures for safety.

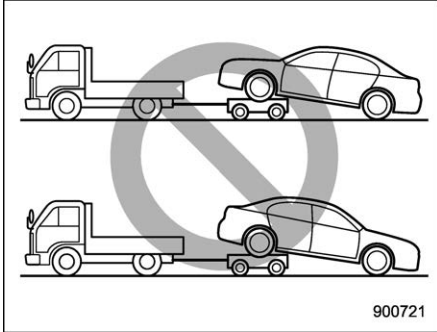

900721

### WARNING

**Never tow AWD models (both CVT and MT models) with the front wheels raised off the ground while the rear wheels are on the ground, or with the rear wheels raised off the ground while the front wheels are on the ground. This will cause the vehicle to spin away due to the operation or deterioration of the center differential.**

### ■ Towing and tie-down hooks/holes

The towing hook should be used only in an emergency.

### CAUTION

**Use only the specified towing hook and tie-down hooks/holes. Never use suspension parts or other parts of the body for towing or tie-down purposes.**

### Front towing hook:

1. Take the towing hook, screwdriver and wheel nut wrench out of the tool bucket.

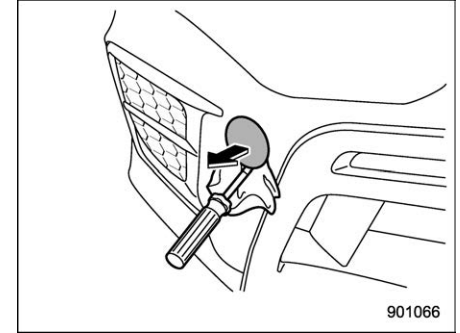

901066

2. Cover the tip of a flat-head screwdriver with vinyl tape or cloth so that it will not scratch the bumper. Insert the flat-head screwdriver into the cutout of the cover and pry open the cover.

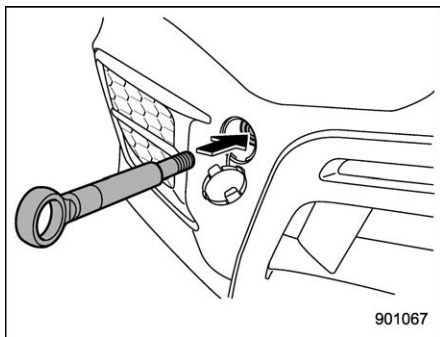

3. Screw the towing hook into the thread hole until its thread can no longer be seen.

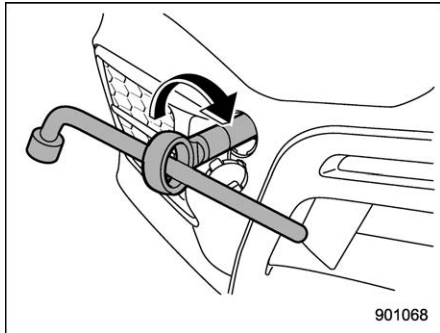

4. Tighten the towing hook securely using the wheel nut wrench.

After towing, remove the towing hook from

the vehicle and stow it in the tool bucket. Fit the towing hook cover on the bumper.

**WARNING**

- Do not use the towing hook except when towing your vehicle.
- Be sure to remove the towing hook after towing. Leaving the towing hook mounted on the vehicle could interfere with proper operation of the SRS airbag system in a frontal collision.

**CAUTION**

To prevent deformation to the bumper and the towing hook, do not apply an excessive load to the towing hook.

**Rear towing hook:**

1. Take the towing hook, screwdriver and wheel nut wrench out of the tool bucket.

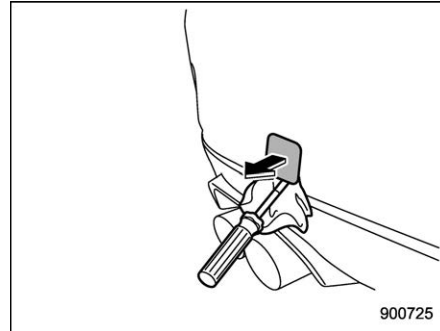

2. Pry off the cover on the rear bumper using a screwdriver, and you will find a threaded hole for attaching the towing hook.

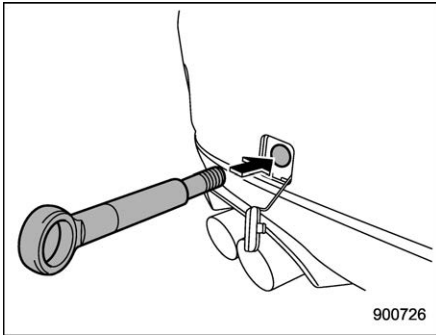

3. Screw the towing hook into the thread hole until its thread can no longer be seen.

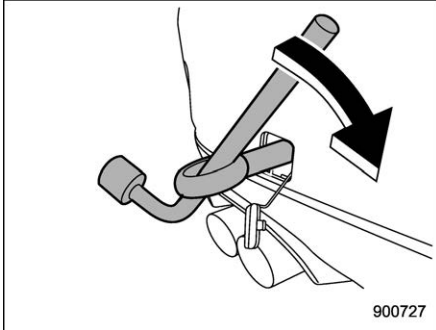

4. Tighten the towing hook securely using the wheel nut wrench.

After towing, remove the towing hook from the vehicle and stow it in the tool bucket. Fit the towing hook cover on the bumper.

**⚠ WARNING**

**Do not use the towing hook except when towing your vehicle.**

**Be sure to remove the towing hook after towing. Leaving the towing hook mounted on the vehicle could interfere with proper operation of the fuel pump shut off function when the vehicle is struck from behind.**

**⚠ CAUTION**

**To prevent deformation to the bumper and the towing hook, do not apply an excessive load to the towing hook.**

**Front tie-down hooks:**

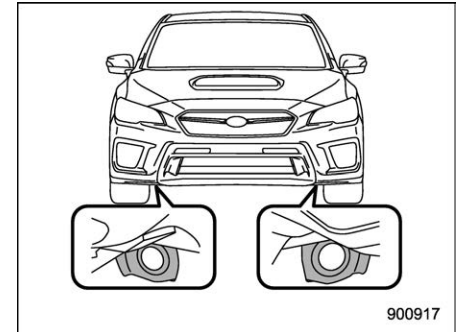

The front tie-down hooks are located between each of the front tires and the front bumper.

**Rear tie-down holes:**

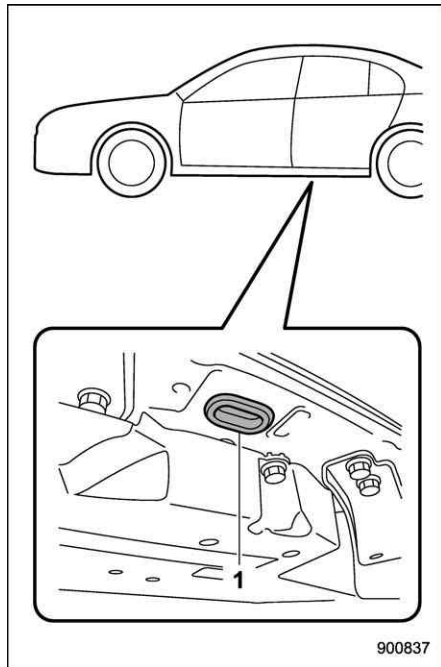

1) Rear tie-down hole

The rear tie-down holes are located near each of the jack-up reinforcements.

There is a plug in each rear tie-down hole. To use the rear tie-down holes, remove the

plugs. After using the rear tie-down holes, return the plugs to their original places.

**⚠ WARNING**

**Use the rear tie-down holes only for downward anchoring. If they are used to anchor the vehicle in any other direction, cables may slip out of the holes, possibly causing a dangerous situation.**

**■ Using a flat-bed truck**

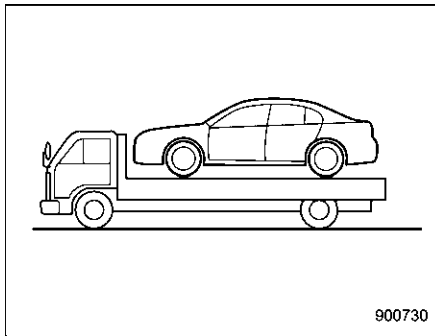

This is the best way to transport your vehicle. Use the following procedures to ensure safe transportation.

1. Shift the select lever into the “P” position for CVT models. Shift the shift lever into the “1st” position for MT models.

2. Apply the parking brake firmly.

3. Secure the vehicle onto the carrier properly with safety chains. Each safety chain should be equally tightened and care must be taken not to pull the chains so tightly that the suspension bottoms out.

**⚠ CAUTION**

**If your vehicle has a front under-spoiler and rear under-spoiler (both optional), be careful not to scrape them when placing the vehicle on the carrier and when removing the vehicle from the carrier.**

## ■ Towing with all wheels on the ground

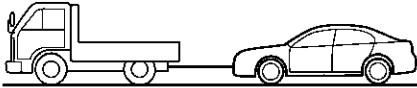

900731

1. Release the parking brake and put the transmission in the "N"/neutral position.
2. The ignition switch should be in the "ON" position while the vehicle is being towed.
3. Take up slack in the towline slowly to prevent damage to the vehicle.



### WARNING

- Never turn the ignition switch to the "LOCK"/"OFF" position while the vehicle is being towed because the steering wheel and the direction of the wheels will be locked.

- Remember that the brake booster and power steering do not function when the engine is not running. Because the engine is turned off, it will take greater effort to operate the brake pedal and steering wheel.



### CAUTION

- If transmission failure occurs, transport your vehicle on a flat-bed truck.
- Sometime damaged vehicles cannot be towed because of their damaged conditions.  
In this case, use a flat-bed truck for transportation.
- For CVT models, the traveling speed must be limited to less than 20 mph (32 km/h) and the traveling distance to less than 31 miles (50 km). For greater speeds and distances, transport your vehicle on a flat-bed truck.
- Use a flat-bed truck if there are a long distance downgrades or steep slopes. However, do not apply the brake pedal for a long time because the engine braking will not work while towing. Doing

- so could overheat the brake.
- Drive carefully and do not make an impact on the towing rope by suddenly starting.
- Use a specific towing rope for towing. If wire ropes and metal chains are needed to be used for towing, wrap the contact portion of the bumper with cloth to protect it from damage.

## **Electronic parking brake – if the electronic parking brake cannot be released (models with electronic parking brake system)**

Contact your SUBARU dealer and have your SUBARU dealer release the electronic parking brake.

## **Access key fob – if access key fob does not operate properly**

### **CAUTION**

**Keep metallic objects, magnetic sources and signal transmitters away from the area between the access key fob and the push-button ignition switch. They may interfere with the communication between the access key fob and the push-button ignition switch.**

The following functions may be inoperable because of strong radio signals in the surrounding area or a low battery condition of the access key fob.

- Locking/unlocking doors
- Switching power status
- Starting the engine

In such cases, perform the following procedure. When the battery of the access key fob is discharged, replace it with a new one. Refer to “Replacing battery of access key fob” 11-52.

## **Locking and unlocking**

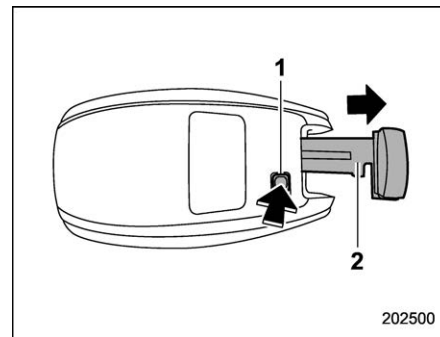

- 1) Release button
- 2) Emergency key

While pressing the release button of the access key fob, take out the emergency key.

Lock or unlock the driver's door with the emergency key.

### **NOTE**

**After locking or unlocking, be sure to reinsert the emergency key into the access key fob.**

## ■ Switching power status

1. Apply the parking brake.
2. Shift the shift lever into neutral (MT models) or the select lever into the “P” position (CVT models).
3. Depress the clutch pedal (MT models) or brake pedal (CVT models).

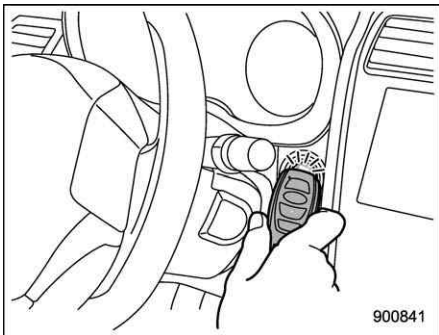

4. Hold the access key fob with the buttons facing you, and touch the push-button ignition switch with it.

When the communication between the access key fob and the vehicle is completed, a chime (ding) will sound. At the same time, the status of the push-button ignition switch changes to either of the following.

- When the keyless access with push-button start system is deactivated: “ACC”
  - Under other conditions: “ON”
5. When the keyless access with push-button start system is deactivated, press the push-button ignition switch with the clutch pedal (MT models) or brake pedal (CVT models) released. The status of the push-button ignition switch then changes to “ON”.

## NOTE

**If the power does not switch even though the above procedure was followed precisely, contact your SUBARU dealer.**

## ■ Starting engine

1. Apply the parking brake.
2. Shift the shift lever into neutral (MT models) or the select lever into the “P” position (CVT models).
3. Depress the brake pedal (all models).
4. Depress the clutch pedal (MT models).

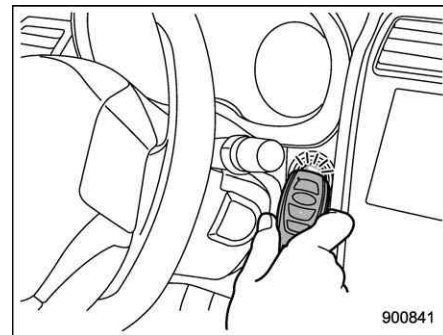

5. Hold the access key fob with the buttons facing you, and touch the push-button ignition switch with it.

When the communication between the access key fob and the vehicle is completed, a chime (ding) will sound. At the same time, the push-button ignition switch turns to the “ACC” or “ON” position.

6. Within 5 seconds after the push-button ignition switch turns to the “ACC” or “ON” position, while depressing the brake pedal (all models) and the clutch pedal (MT models), press the push-button ignition switch.

**NOTE**

If the engine does not start even though the above procedure was followed precisely, contact your SUBARU dealer.

**Moonroof (if equipped) – if the moonroof does not close**

If the moonroof does not close, we recommend that you have the system checked by a SUBARU dealer.

**If your vehicle is involved in an accident**



**CAUTION**

**If your vehicle is involved in an accident, be sure to inspect the ground under the vehicle before restarting the engine. If you find that fuel has leaked on the ground, do not try to restart the engine. The fuel system has been damaged and is in need of repair. Immediately contact the nearest automotive service facility. We recommend that you consult your SUBARU dealer.**

Your vehicle has a fuel pump shut off system. To minimize the risk of fire due to fuel leakage when your vehicle is subject to impact from an accident or another factor, the system stops supplying fuel. However, depending on the impact conditions at the time of collision, the fuel pump shut-off system may not operate.

Perform the following procedures to restart the engine after the system is activated.



**Models without “keyless access with push-button start system”:**

1. Turn the ignition switch to the “LOCK” or “ACC” position.
2. Restart the engine.

**Models with “keyless access with push-button start system”:**

1. Turn the push-button ignition switch to the “ACC” or “OFF” position.
2. Restart the engine.

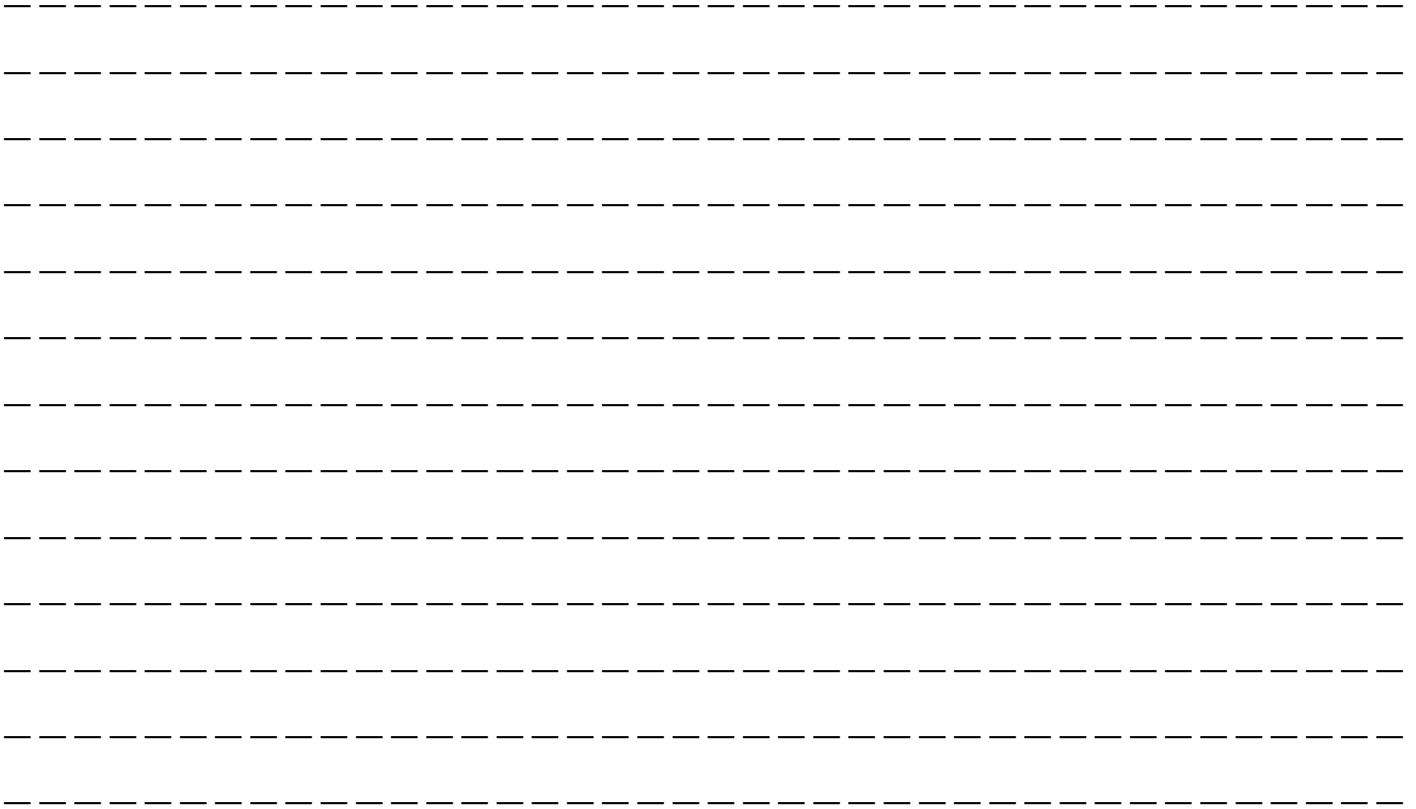

# Appearance care

Exterior care .....	10-2
Washing .....	10-2
Waxing and polishing.....	10-3
Cleaning alloy wheels .....	10-3
Corrosion protection .....	10-4
Most common causes of corrosion .....	10-4
To help prevent corrosion .....	10-4

Cleaning the interior.....	10-5
Seat fabric.....	10-5
Leather Seat Materials .....	10-5
Synthetic leather upholstery .....	10-5
Climate control panel, audio panel, instrument panel, console panel, and switches.....	10-6
Monitor.....	10-6

## Exterior care

### ■ Washing

#### CAUTION

- When washing the vehicle, the brakes may get wet. As a result, the brake stopping distance will be longer. To dry the brakes, drive the vehicle at a safe speed while lightly depressing the brake pedal to heat up the brakes.
- Do not wash the engine compartment and area adjacent to it. If water enters the engine air intake or electrical parts, it will cause engine trouble or a malfunction of electrical equipment.
- When washing the inner fenders, underbody, bumpers and protruding objects such as exhaust pipes and exhaust finishers, be careful to prevent injuries from contacting sharp ends.
- Do not use any organic solvents when washing the surface of the bulb assembly cover. However, if a detergent with organic solvents is used to wash the cover surface, completely rinse off the detergent with water. Otherwise,

the cover surface may be damaged.

#### NOTE

**When having your vehicle washed in an automatic car wash, make sure beforehand that the car wash is of suitable type.**

The best way to preserve your vehicle's beauty is frequent washing. Wash the vehicle at least once a month to avoid contamination by road grime.

Wash dirt off with a wet sponge and plenty of lukewarm or cold water. Do not wash the vehicle with hot water and in direct sunlight.

Salt, chemicals, insects, tar, soot, tree sap, and bird droppings should be washed off by using a light detergent, as required. If you use a light detergent, make certain that it is a neutral detergent. Do not use strong soap or chemical detergents. All cleaning agents should be promptly rinsed off the surface and not allowed to dry there. Rinse the vehicle thoroughly with plenty of lukewarm water. Wipe the remaining water off with a chamois or soft cloth. Wear rubber gloves and use a hand brush when washing down underbody, inner fenders and suspension to effectively remove mud

and dirt off.

#### ▼ Washing the underbody

Chemicals, salts and gravel used for deicing road surfaces are extremely corrosive, accelerating the corrosion of underbody components, such as the exhaust system, fuel and brake lines, brake cables, floor pan and fenders, and suspension.

Thoroughly flush the underbody and inside of the fenders with lukewarm or cold water at frequent intervals to reduce the harmful effects of such agents.

Mud and sand adhering to the underbody components may accelerate their corrosion.

After driving off-road or on muddy or sandy roads, wash the mud and sand off the underbody. Carefully flush the suspension and axle parts, as they are particularly prone to mud and sand buildup. Do not use a sharp-edged tool to remove caked mud.

#### CAUTION

- **Be careful not to damage brake hoses, sensor harnesses, and other parts when washing suspension components.**
- **Be careful not to flush the engine bottom for a long time. It may cause damage of some electrical**

**parts.****▼ Using a warm water washer**

- Keep a good distance of 12 in (30 cm) or more between the washer nozzle and the vehicle.
- Do not wash the same area continuously.
- If a stain will not come out easily, wash by hand. Some warm water washers are of the high temperature, high pressure type, and they can damage or deform the resin parts such as moldings, or cause water to leak into the vehicle.

**■ Waxing and polishing**

Always wash and dry the vehicle before waxing and polishing.

Use a good quality polish and wax and apply them according to the manufacturer's instructions. Wax or polish when the painted surface is cool.

Be sure to polish and wax the chrome trim, as well as the painted surfaces. Loss of wax on a painted surface leads to loss of the original luster and also quickens the deterioration of the surface. It is recommended that a coat of wax be applied at least once a month, or whenever the surface no longer repels water.

If the appearance of the paint has diminished to the point where the luster or tone cannot be restored, lightly polish the surface with a fine-grained compound. Never polish just the affected area, but include the surrounding area as well. Always polish in only one direction. A No. 2000 grain compound is recommended. Never use a coarse-grained compound. Coarse-grained compounds have a smaller grain-size number and could damage the paint. After polishing with a compound, coat with wax to restore the original luster. Frequent polishing with a compound or an incorrect polishing technique will result in removing the paint layer and exposing the undercoat. When in doubt, it is always best to contact your SUBARU dealer or an auto paint specialist.

**CAUTION**

**Do not use any agents with organic solvents on the surface of the bulb assembly cover. However, if a polish or wax with organic solvents is applied to the cover surface, completely wipe off the polish or wax. Otherwise, the cover surface may be damaged.**

**NOTE**

**Be careful not to block the windshield washer nozzles with wax when waxing the vehicle.**

**■ Cleaning alloy wheels**

- Promptly wipe the alloy wheels clean of any kind of grime or agent. If dirt is left on too long, it may be difficult to clean off.
- Do not use soap containing grit to clean the wheels. Be sure to use a neutral cleaning agent, and later rinse thoroughly with water. Do not clean the wheels with a stiff brush or expose them to a high-speed washing device.
- Clean the vehicle (including the alloy wheels) with water as soon as possible when it has been splashed with sea water, exposed to sea breezes, or driven on roads treated with salt or other agents.

### Corrosion protection

Your SUBARU has been designed and built to resist corrosion. Special materials and protective finishes have been used on most parts of the vehicle to help maintain fine appearance, strength, and reliable operation.

#### ■ Most common causes of corrosion

The most common causes of corrosion are:

- The accumulation of moisture retaining dirt and debris in body panel sections, cavities, and other areas.
- Damage to paint and other protective coatings caused by gravel and stone chips or minor accidents.

Corrosion is accelerated on the vehicle when:

- It is exposed to road salt or dust control chemicals, or used in coastal areas where there is more salt in the air, or in areas where there is considerable industrial pollution.
- It is driven in areas of high humidity, especially when temperatures range just above freezing.

- Dampness in certain parts of the vehicle remains for a long time, even though other parts of the vehicle may be dry.

- High temperatures will cause corrosion to parts of the vehicle which cannot dry quickly due to lack of proper ventilation.

#### ■ To help prevent corrosion

Wash the vehicle regularly to prevent corrosion of the body and suspension components. Also, wash the vehicle promptly after driving on any of the following surfaces.

- Roads that have been salted to prevent them from freezing in winter
- Mud, sand, or gravel
- Coastal roads

After the winter has ended, it is recommended that the underbody be given a very thorough washing.

Before the beginning of winter, check the condition of underbody components, such as the exhaust system, fuel and brake lines, brake cables, suspension, steering system, floor pan, and fenders. If any of them are found to be rusted, they should be given an appropriate rust prevention treatment or should be replaced. Contact your SUBARU dealer to perform this kind

of maintenance and treatment if you need assistance.

Repair chips and scratches in the paint as soon as you find them.

Check the interior of the vehicle for water and dirt accumulation under the floor mats because that could cause corrosion. Occasionally check under the mats to make sure the area is dry.

Keep your garage dry. Do not park your vehicle in a damp, poorly ventilated garage. In such a garage, corrosion can be caused by dampness. If you wash the vehicle in the garage or put the vehicle into the garage when wet or covered with snow, that can cause dampness.

If your vehicle is operated in cold weather and/or in areas where road salts and other corrosive materials are used, the door hinges and locks, and hood latch should be inspected and lubricated periodically.

## Cleaning the interior

Use a soft, damp cloth to clean the climate control panel, audio equipment, instrument panel, center console, combination meter panel, and switches. (Do not use organic solvents.)

### ■ Seat fabric

Remove loose dirt, dust or debris with a vacuum cleaner. If the dirt is caked on the fabric or hard to remove with a vacuum cleaner, use a soft brush then vacuum it.

Wipe the fabric surface with a tightly wrung cloth and dry the seat fabric thoroughly. If the fabric is still dirty, wipe using a solution of mild soap and lukewarm water then dry thoroughly.

If the stain does not come out, try a commercially-available fabric cleaner. Use the cleaner on a hidden place and make sure it does not affect the fabric adversely. Use the cleaner according to its instructions.



### CAUTION

**When cleaning the seat, do not use benzine, paint thinner, or any similar materials. Doing so could damage the surface and cause the color to**

deteriorate.

### ■ Leather Seat Materials

The leather used by SUBARU is a high quality natural product which will retain its distinctive appearance and feel for many years with proper care.

Allowing dust or road dirt to build up on the surface can cause leather to become brittle and wear prematurely. To maintain its resiliency, leather should be cleaned monthly or whenever it becomes soiled.

Before cleaning leather upholstery, vacuum it to remove dust. Use a soft and lint-free cloth dampened with lukewarm water and mild soap, taking care not to soak the leather or allow water to penetrate the stitched seams. Use a gentle circular motion while cleaning the leather - do not rub or apply extreme pressure. Wipe the leather again with another clean, slightly damp cloth to remove soap residue and dry with a soft cloth.

Minor surface blemishes or difficult dirt spots may be treated with a commercial leather spray. Never use alcohol, cleaning solvents, leather oils, varnishes or polishes on your leather as it will dry out the leather finish.

If your SUBARU is to be parked for a long

time in bright sunlight, it is recommended that the seats and headrests be covered, or the windows shaded, to prevent fading or shrinkage.

You will discover that each leather seat section will develop soft folds or wrinkles, which is characteristic of genuine leather.

### ■ Synthetic leather upholstery

The synthetic leather material used on the SUBARU may be cleaned using mild soap or detergent and water, after first vacuuming or brushing away loose dirt. Allow the soap to soak in for a few minutes and wipe off with a clean, damp cloth. Commercial foam-type cleaners suitable for synthetic leather materials may be used when necessary.



### CAUTION

**Strong cleaning agents such as solvents, paint thinners, window cleaner or fuel must never be used on leather or synthetic interior materials. Doing so could damage the surface and cause the color to deteriorate.**

### ■ Climate control panel, audio panel, instrument panel, console panel, and switches

Use a soft, damp cloth to clean the climate control panel, audio equipment, instrument panel, center console, combination meter panel, and switches.



#### CAUTION

- Do not use organic solvents such as paint thinners or fuel, or strong cleaning agents that contain those solvents. Doing so could damage the surface and cause the color to deteriorate.
- Do not use chemical solvents that contain silicone on the vehicle audio system, electrical components of the air-conditioner or any switches. If silicone adheres to these parts, it may cause damage to electrical components.

### ■ Monitor

To clean the audio/navigation/multi-function display monitor, wipe it with a silicone cloth or with a soft cloth. If the monitor is extremely dirty, clean it with a soft cloth moistened with neutral detergent then carefully wipe off any remaining detergent.



#### CAUTION

- Do not spray neutral detergent directly onto the monitor. Doing so could damage the monitor's components.
- Do not wipe the monitor with a hard cloth. Doing so could scratch the monitor.
- Do not use cleaning fluid that contains thinner, fuel, or any other volatile substance. Such cleaning fluid could erase the lettering on the switches at the bottom of the monitor.



# Maintenance and service

Maintenance schedule.....	11-3	Continuously variable transmission fluid.....	11-22
Maintenance precautions .....	11-3	Front differential gear oil (CVT models) and rear differential gear oil.....	11-22
Before checking or servicing in the engine compartment .....	11-4	Recommended grade and viscosity.....	11-22
When checking or servicing in the engine compartment .....	11-5	Power steering fluid (STI) .....	11-22
When checking or servicing in the engine compartment while the engine is running .....	11-5	Checking the fluid level .....	11-22
Maintenance tips.....	11-6	Recommended fluid.....	11-23
Removing and reinstalling clips .....	11-6	Brake fluid.....	11-23
Engine hood .....	11-9	Checking the fluid level .....	11-23
Engine compartment overview .....	11-11	Recommended brake fluid .....	11-24
STI.....	11-11	Clutch fluid (MT models).....	11-24
Except STI .....	11-12	Checking the fluid level .....	11-24
Engine oil.....	11-13	Recommended clutch fluid .....	11-25
Engine oil consumption .....	11-13	Brake booster .....	11-25
Checking the oil level.....	11-13	Brake pedal .....	11-26
Changing the oil and oil filter .....	11-15	Checking the brake pedal free play .....	11-26
Recommended grade and viscosity.....	11-15	Checking the brake pedal reserve distance .....	11-26
Synthetic oil.....	11-15	Clutch pedal (MT models).....	11-27
Cooling system .....	11-16	Checking the clutch function .....	11-27
Cooling fan, hose and connections .....	11-16	Checking the clutch pedal free play .....	11-27
Engine coolant.....	11-17	Hill start assist system .....	11-27
Air cleaner element.....	11-18	Replacement of brake pad and lining.....	11-28
Replacing the air cleaner element.....	11-19	Breaking-in of new brake pads (models with electronic parking brake system) .....	11-28
Spark plugs .....	11-20	Breaking-in of new brake pads and linings (models without electronic parking brake system) .....	11-28
Recommended spark plugs .....	11-20	Parking brake stroke (models without electronic parking brake system).....	11-29
Drive belts .....	11-20		
Manual transmission oil .....	11-21		
Recommended grade and viscosity.....	11-21		

<b>Tires and wheels</b> .....	<b>11-29</b>	<b>Replacing bulbs</b> .....	<b>11-44</b>
Types of tires .....	11-29	Headlights (models with LED headlights) .....	11-44
Tire pressure monitoring system (TPMS) (if equipped) .....	11-30	High beam headlight (models without LED headlights) .....	11-44
Tire inspection .....	11-31	Low beam headlight, front side marker light, parking light and front turn signal light .....	11-45
Tire pressures and wear .....	11-32	Front turn signal light (models with LED headlights) .....	11-47
Wheel balance .....	11-34	Front fog light (models with the LED front fog light) .....	11-48
Wear indicators .....	11-34	Front fog light (models without the LED front fog light) (if equipped) .....	11-48
Rotational direction of tires .....	11-35	Rear combination lights .....	11-49
Tire rotation .....	11-35	License plate light .....	11-50
Tire replacement .....	11-36	Dome light .....	11-51
Wheel replacement .....	11-37	Trunk light .....	11-51
<b>Alloy wheels</b> .....	<b>11-37</b>	Vanity mirror light .....	11-51
<b>Windshield washer fluid</b> .....	<b>11-38</b>	Other bulbs .....	11-51
<b>Replacement of wiper blades</b> .....	<b>11-39</b>	<b>Replacing battery</b> .....	<b>11-52</b>
Windshield wiper blade assembly .....	11-39	Safety precautions .....	11-52
Windshield wiper blade rubber .....	11-40	Replacing battery of access key fob .....	11-52
<b>Battery</b> .....	<b>11-41</b>	Replacing transmitter battery .....	11-53
<b>Fuses</b> .....	<b>11-42</b>		
<b>Installation of accessories</b> .....	<b>11-43</b>		

## Maintenance schedule

### U.S. models

The scheduled maintenance items required to be serviced at regular intervals are shown in the “Warranty and Maintenance Booklet”. For details, read the separate “Warranty and Maintenance Booklet”.

### Canada models

The scheduled maintenance items required to be serviced at regular intervals are shown in the “Warranty and Service Booklet”. For details, read the separate “Warranty and Service Booklet”.

### Other models

Some items of your vehicle are required to be serviced at scheduled intervals. For details about your maintenance schedule, read the separate “Warranty and Maintenance Booklet”.

### NOTE

You can set a reminder to be displayed when a scheduled maintenance item is almost due. For details, refer to “Maintenance settings” 3-58.

## Maintenance precautions

When maintenance and service are required, it is recommended that all work be done by an authorized SUBARU dealer.

If you perform maintenance and service by yourself, you should familiarize yourself with the information provided in this section on general maintenance and service for your SUBARU.

Incorrect or incomplete service could cause improper or unsafe vehicle operation. Any problems caused by improper maintenance and service performed by you are not eligible for warranty coverage.



### WARNING

- **Testing of an All-Wheel Drive model must NEVER be performed on a single two-wheel dynamometer or similar apparatus. Attempting to do so will result in transmission damage and in uncontrolled vehicle movement and may cause an accident or injuries to persons nearby.**
- Always select a safe area when performing maintenance on your vehicle.

- Always be very careful to avoid injury when working on the vehicle. Remember that some of the materials in the vehicle may be hazardous if improperly used or handled, for example, battery acid.
- Your vehicle should only be serviced by persons fully competent to do so. Serious personal injury may result to persons not experienced in servicing vehicles.
- Always use the proper tools and make certain that they are well maintained.
- Never get under the vehicle supported only by a jack. Always use safety stands to support the vehicle.
- Never keep the engine running in a poorly ventilated area, such as a garage or other closed areas.
- Do not smoke or allow open flames around the fuel or battery. This will cause a fire.
- Because the fuel system is under pressure, replacement of the fuel filter should be performed only by your SUBARU dealer.

- Wear adequate eye protection to guard against getting oil or fluids in your eyes. If something does get in your eyes, thoroughly wash them out with clean water.
- Do not tamper with the wiring of the SRS airbag system or seatbelt pretensioner system, or attempt to take its connectors apart, as that may activate the system or it can render it inoperative. NEVER use a circuit tester for this wiring. If your SRS airbag or seatbelt pretensioner needs service, consult your nearest SUBARU dealer.
- Check the inside of the engine compartment to see if there are any cloths and tools left. If they are left inside, they may be a cause of malfunction and fire.

#### NOTE

SUBARU does not endorse the use of non-SUBARU approved flushing systems and strongly advises against performing these services on a SUBARU vehicle. Non-SUBARU approved flushing systems use chemicals and/or solvents which have not been tested or approved by SUBARU.

SUBARU warranties do not cover any part of the vehicle which is damaged by adding or applying chemicals and/or solvents other than those approved or recommended by SUBARU.

#### ■ Before checking or servicing in the engine compartment



#### WARNING

- Always stop the engine and apply the parking brake to prevent the vehicle from moving.
- Always let the engine cool down. Engine parts become very hot when the engine is running and remain hot for some time after the engine has stopped.
- Do not spill engine oil, engine coolant, brake fluid or any other fluid on hot engine components. This may cause a fire.
- When the ignition switch is in the "ON" position, the cooling fan may operate suddenly even when the engine is stopped. If your body or clothes come into contact with a rotating fan, that could result in serious injury. To avoid risk of injury, perform the follow-

ing precautions.

- Models with push-button start system:  
Always turn the push-button ignition switch to the "OFF" position and confirm that the operation indicator on the switch is turned off. Then take the access key fob out from the vehicle.
- Models without push-button start system:  
Always remove the key from the ignition switch.
- Before performing any servicing on a vehicle equipped with a remote engine start system (a dealer option) temporarily place that system in the service mode to prevent it from unexpectedly starting the engine.

## ■ When checking or servicing in the engine compartment

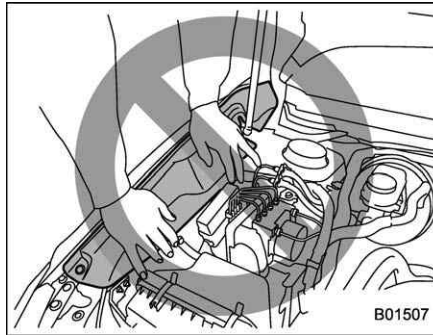
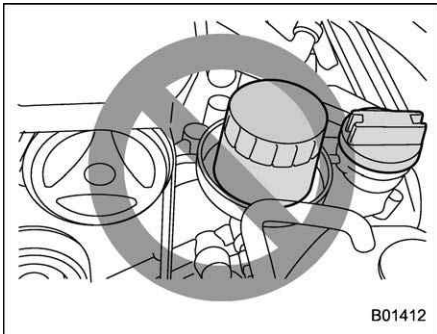
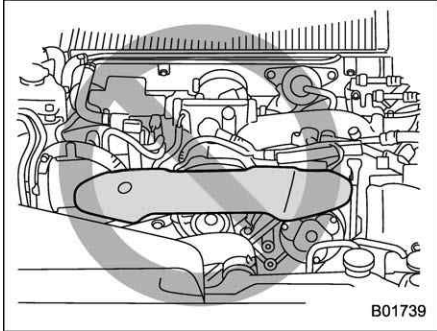

### ⚠ CAUTION

- Do not contact the drive belt cover while checking the components in the engine compartment. Doing so may cause your hand to slip off the cover and result in an unexpected injury.
- Do not touch the oil filter until the engine has cooled down completely. Doing so may result in a burn or other injury. Note that the oil filter becomes very hot when the engine is running and remains hot for some time after the engine has stopped.
- Do not apply force on the fender insulator by placing your hands

on it, etc. Deformation of the insulator and its mount may occur.

## ■ When checking or servicing in the engine compartment while the engine is running

### ⚠ WARNING

A running engine can be dangerous. Keep your fingers, hands, clothing, hair and tools away from the cooling fan, drive belt and any other moving engine parts. Removing rings, watches and ties is advisable.

## Maintenance tips

Some clips and fender linings must be removed before replacing the air cleaner elements or specific bulbs.

### ■ Removing and reinstalling clips

#### ▼ Removing clips

There are several types of clips used for your vehicle.

##### ▽ Type A clips

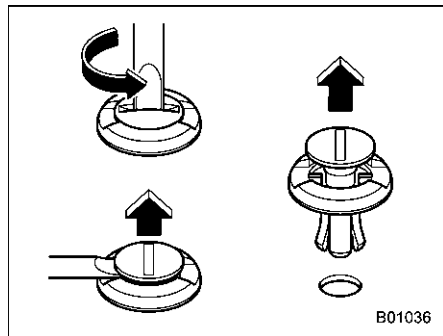

1. Turn the clips counterclockwise using a flat-head screwdriver until the center portion of the clip is raised.
2. Remove the clips with a flat-head screwdriver using leverage.

3. Remove the entire clip by pulling it up.

##### ▽ Type B clips

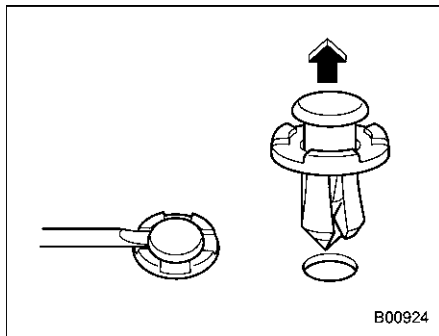

##### ▽ Type C clips

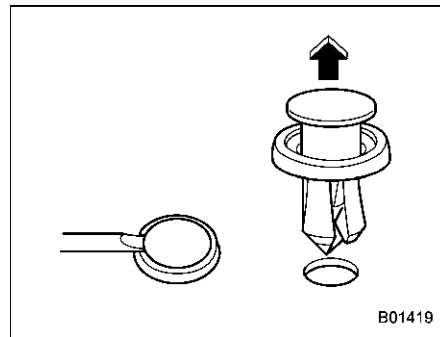

1. Pull out the center portion of the clip using a flat-head screwdriver as shown in the illustration.
2. Pull the protruded center portion to remove the entire body of the clip.

## ▽ Type D clips

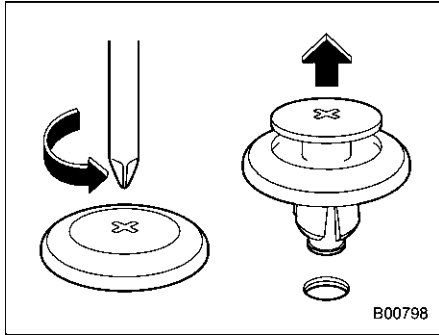

B00798

1. Turn the clip counterclockwise using a Phillips screwdriver until the center portion of the clip is raised.
2. Remove the entire clip by pulling it up.

## ▽ Type E clips

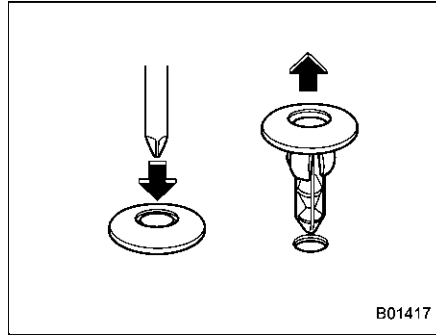

B01417

1. Push the center portion of the clip using a Phillips screwdriver until the clip is raised.
2. Remove the entire clip by pulling it up.

## ▽ Type F clips

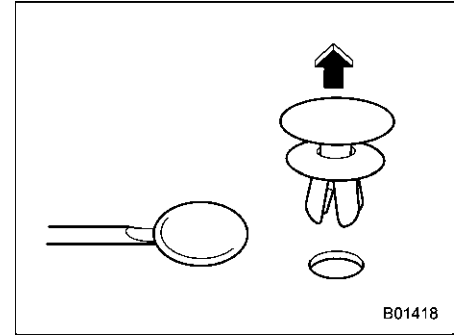

B01418

1. Pull out the head of the clip using a flat-head screwdriver as shown in the illustration.
2. Remove the entire clip by pulling it up.

▼ Reinstalling clips

▽ Type A clips

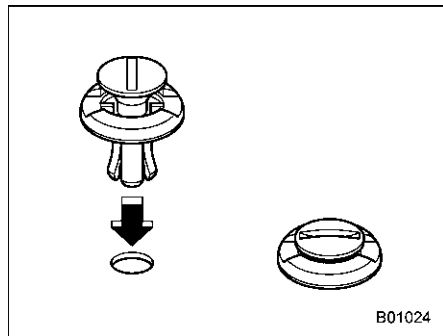

▽ Type B clips

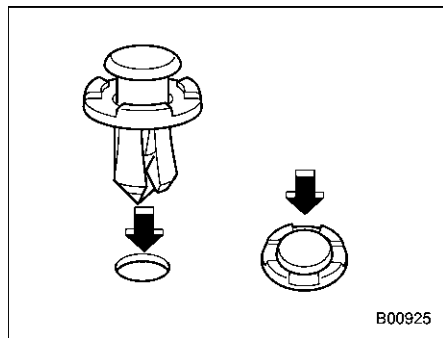

▽ Type C clips

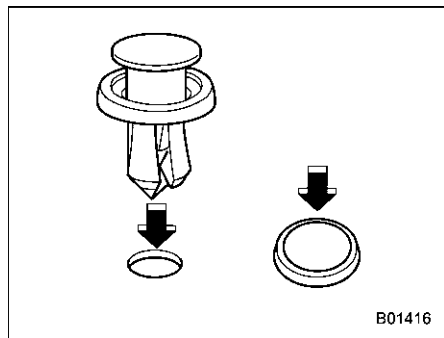

▽ Type D clips

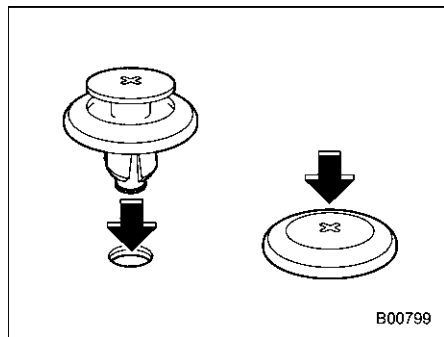

▽ Type E clips

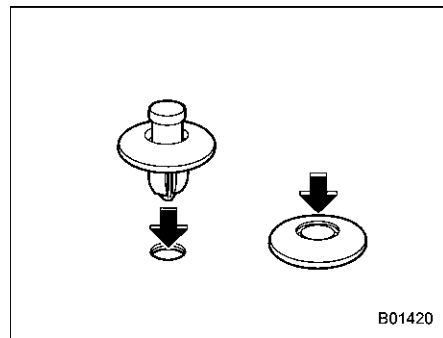

Insert the clip without the center portion first and then push the center portion of the clip into the hole.



## ▽ Type F clips

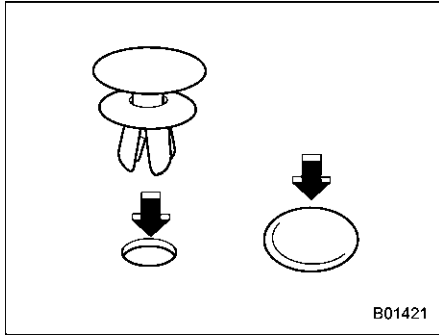

Insert the clip without the head first and then push the head of the clip into the hole.

## Engine hood

**To open the hood:**

1. If the wiper blades are lifted off the windshield, return them to their original position.

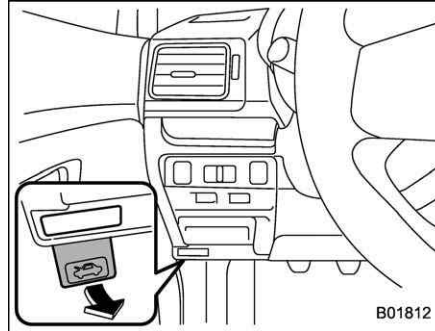

2. Pull the hood release knob under the instrument panel.

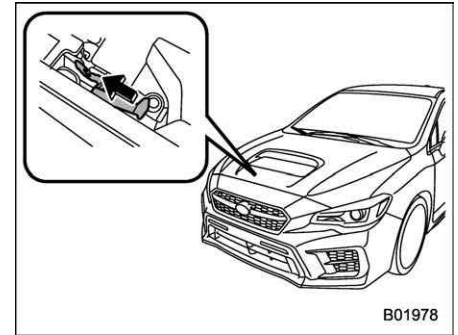

3. Release the secondary hood release by moving the lever between the front grille and the hood toward the left.  
4. Lift up the hood.

**To close the hood:**

1. Lower the hood to a height of approximately 11.8 in (30 cm) above its closed position and then let it drop.  
2. After closing the hood, be sure the hood is securely locked.

If this does not close the hood, release it from a slightly higher position.

**⚠ WARNING**

**Always check that the hood is properly locked before you start**

driving. If it is not, it might fly open while the vehicle is moving and block your view, which may cause an accident and serious bodily injury.



**CAUTION**

- Be extremely careful not to catch fingers or other objects when closing the engine hood.
- Do not push the hood forcibly to close it. It could deform the metal.
- Be extremely careful opening the engine hood when the wind is strong. The engine hood could close suddenly, possibly causing injuries from slamming.
- Do not install accessories other than genuine SUBARU parts to the engine hood. If the engine hood becomes too heavy, the stay may not be able to support holding it open.
- Do not jam a plastic bag in or place cellophane tape on the engine hood stays or scratch the stays. That could cause leakage of gas from the stays, which may result in their inability to hold the engine hood open.

- Do not put your hands on the engine hood stay or push it horizontally. Doing so could bend the engine hood stay and the trunk will not open or close.
- Do not disassemble the engine hood stays. Also, do not dispose of them in a fire.

## Engine compartment overview

### ■ STI

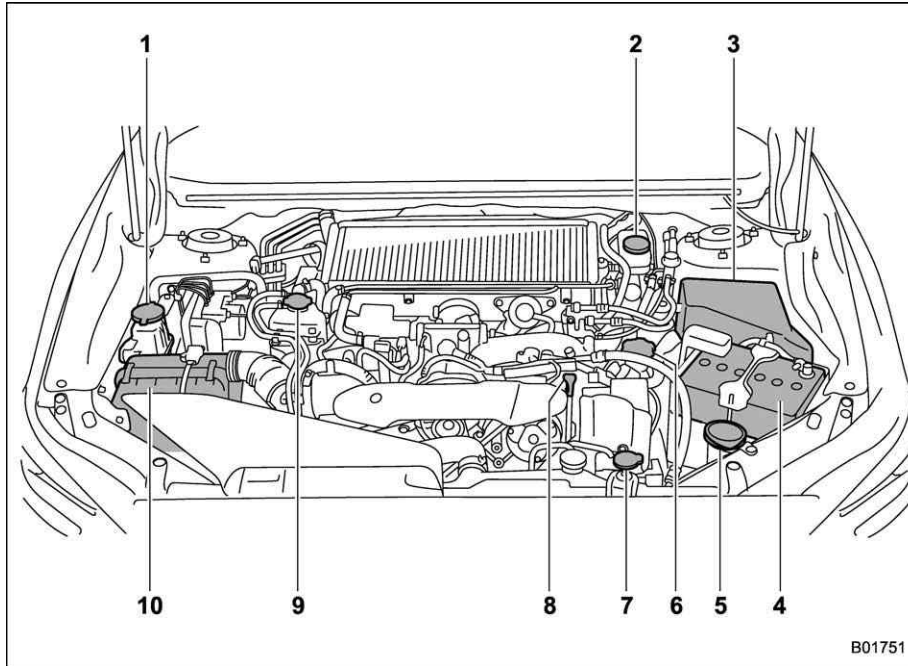

- 1) Power steering fluid reservoir (page 11-22)
- 2) Brake fluid reservoir/Clutch fluid reservoir (page 11-23)
- 3) Fuse box (page 11-42)
- 4) Battery (page 11-41)
- 5) Windshield washer tank (page 11-38)
- 6) Engine oil filler cap (page 11-13)
- 7) Engine coolant reservoir (page 11-17)
- 8) Engine oil level gauge (page 11-13)
- 9) Coolant filler tank cap (page 11-17)
- 10) Air cleaner case (page 11-18)

■ **Except STI**

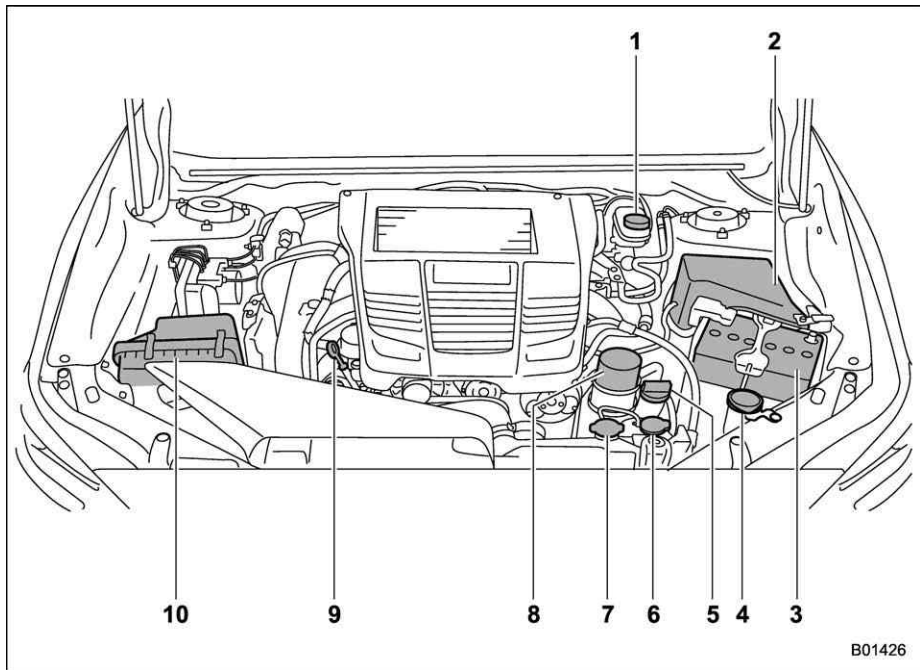

B01426

- 1) Brake fluid reservoir/Clutch fluid reservoir (MT models) (page 11-23)
- 2) Fuse box (page 11-42)
- 3) Battery (page 11-41)
- 4) Windshield washer tank (page 11-38)
- 5) Engine oil filler cap (page 11-13)
- 6) Engine coolant reservoir (page 11-17)
- 7) Radiator cap (page 11-17)
- 8) Engine oil filter (page 11-15)
- 9) Engine oil level gauge (page 11-13)
- 10) Air cleaner case (page 11-18)

## Engine oil

### CAUTION

- If the level gauge is not pulled out easily, twist the level gauge right and left, then pull it out. Otherwise, you may be injured accidentally straining yourself.
- Use only engine oil with the recommended grade and viscosity.
- Be careful not to spill engine oil when adding it. If oil touches the exhaust pipe, it may cause a bad smell, smoke, and/or a fire. If engine oil gets on the exhaust pipe, be sure to wipe it off.

### ■ Engine oil consumption

Some engine oil will be consumed while driving. The rate of consumption can be affected by such factors as transmission type, driving style, terrain and temperature. Under the following conditions, oil consumption can be increased and thus require refilling between maintenance intervals:

- The engine is new and within the break-in period.

- The engine oil is low quality.
- The incorrect oil viscosity is used.
- Engine braking is employed (repeatedly).
- The engine is operated at high engine speeds (for extended periods of time).
- The engine is operated under heavy loads for extended periods of time.
- The engine idles for extended periods of time.
- The vehicle is operated in stop and go and/or heavy traffic situations.
- The vehicle is used under severe thermal conditions.
- The vehicle accelerates and decelerates frequently.

Under these or similar conditions, you should check your oil at least every 2nd fuel fill-up and change your engine oil more frequently. Different drivers in the same car may experience different results. If your oil consumption rate is greater than expected, contact your authorized SUBARU retailer who may perform a test under controlled conditions.

### ■ Checking the oil level

1. Park the vehicle on a level surface and stop the engine. If you check the oil level just after stopping the engine, wait for at least 5 minutes for the oil to drain back into the oil pan before checking the level.

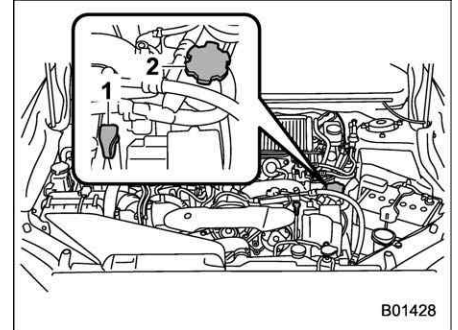

B01428

#### STI

- 1) Oil level gauge
- 2) Oil filler cap

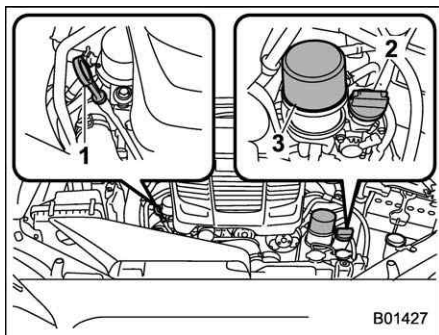

### Except STI

- 1) Oil level gauge
- 2) Oil filler cap
- 3) Oil filter

## CAUTION

If the level gauge is not pulled out easily, twist the level gauge right and left, then pull it out. Otherwise, you may be injured accidentally straining yourself.

2. Pull out the level gauge, wipe it clean, and insert it again.
3. Be sure the level gauge is correctly inserted until it stops.

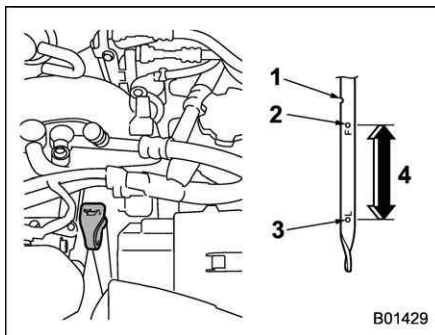

### STI

- 1) Notch
- 2) Full level
- 3) Low level
- 4) Approximately 1.1 US qt (1.0 liter, 0.9 Imp qt) from low level to full level

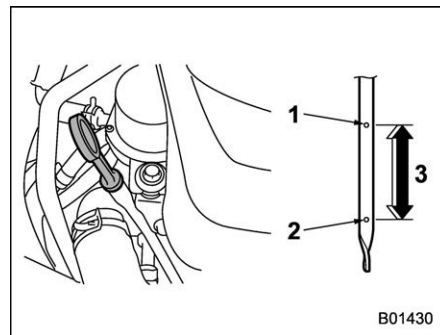

### Except STI

- 1) Full level
- 2) Low level
- 3) Approximately 1.1 US qt (1.0 liter, 0.9 Imp qt) from low level to full level

4. Pull out the oil level gauge again.

### 5. STI:

Check the oil level on the gauge. If the oil level is below the low level mark, add oil so that the full level is reached.

### Except STI:

Check the oil levels on both sides of the level gauge. Judge the engine oil level by the lowest of the two levels. If the oil level is below the low level mark, add oil so that the full level is reached.

**CAUTION**

- For models except STI, be careful not to touch the engine oil filter when removing the oil filler cap. Doing so may result in a burn, a pinched finger, or may cause some other injury.
- Use only engine oil with the recommended grade and viscosity.
- Be careful not to spill engine oil when adding it. If oil touches the exhaust pipe, it may cause a bad smell, smoke, and/or a fire. If engine oil gets on the exhaust pipe, be sure to wipe it off.

To add engine oil, remove the engine oil filler cap and slowly pour engine oil through the filler neck. After pouring oil into the engine, you must use the level gauge to confirm that the oil level is correct.

For models STI, just after driving or while the engine is warm, the engine oil level reading may be in a range between the upper level and the notch mark. This is caused by thermal expansion of the engine oil.

**NOTE**

To prevent overfilling the engine oil, do not add any additional oil above the upper level when the engine is cold.

**■ Changing the oil and oil filter**

Change the oil and oil filter according to the maintenance schedule in the “Warranty and Maintenance Booklet”.

The engine oil and oil filter must be changed more frequently than listed in the maintenance schedule when driving on dusty roads, when short trips are frequently made, or when driving in extremely cold weather.

**NOTE**

- **Changing the engine oil and oil filter should be performed by a well-trained expert. Contact your SUBARU dealer for changing the engine oil and oil filter. Fully trained mechanics are on standby at a SUBARU dealer to utilize the special tools, spare parts and recommended oil for this work, and also, used oils are properly disposed of.**
- **If performing oil replacement yourself, observe the local regulations and dispose of waste oil properly.**

**■ Recommended grade and viscosity****CAUTION**

Use only engine oil with the recommended grade and viscosity.

Refer to “Engine oil” ☞12-4.

**NOTE**

**Engine oil viscosity (thickness) affects fuel economy. Oils of lower viscosity provide better fuel economy. However, in hot weather, oil of higher viscosity is required to properly lubricate the engine.**

**■ Synthetic oil**

You should use synthetic engine oil that meets the same requirements given for conventional engine oil. When using synthetic oil, you must use oil of the same classification, viscosity and grade shown in this Owner’s Manual. Refer to “Engine oil” ☞12-4. Also, you must follow the oil and filter changing intervals shown in the “Warranty and Maintenance Booklet”.

**NOTE**

**Synthetic oil of the grade and viscosity noted in chapter 12 is the recom-**

mended engine oil for optimum engine performance. Conventional oil may be used if synthetic oil is unavailable.

## Cooling system

### WARNING

- Never remove the radiator cap until the engine has been shut off and has cooled down completely. Since the coolant is under pressure, you may suffer serious burns from a spray of boiling hot coolant when the cap is removed.
- Be careful of the rotating cooling fan when the engine hood is open. When the engine temperature is high, the cooling fan in the engine compartment may operate when the ignition switch is in the "ON" position, even if the engine is stopped. Touching the cooling fan while it is rotating may result in injury.

### CAUTION

- Vehicles are filled at the factory with SUBARU SUPER COOLANT that does not require the first change for 11 years/137,500 miles (11 years/220,000 km). Do not mix this coolant with any

other brand or type of coolant during this period. Mixing with a different coolant will reduce the life of the coolant. When necessary to top up the coolant for any reason, use only SUBARU SUPER COOLANT.

If the SUBARU SUPER COOLANT is diluted with another brand or type, the maintenance interval is shortened to that of the mixing coolant.

- Do not splash the engine coolant over painted parts. The alcohol contained in the engine coolant may damage the paint surface.

### ■ Cooling fan, hose and connections

Your vehicle employs an electric cooling fan which is thermostatically controlled to operate when the engine coolant reaches a specific temperature.



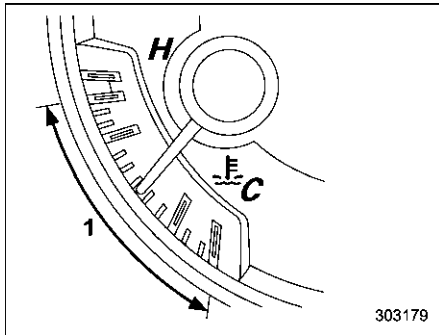

**Temperature gauge**

- 1) Normal operating range

If the radiator cooling fan does not operate even when the engine coolant temperature gauge exceeds the normal operating range, the cooling fan circuit may be defective. Refer to "Temperature gauge" 3-11.

Check the fuse and replace it if necessary. Refer to "Fuses" 11-42 and "Fuses and circuits" 12-10.

If the fuse is not blown, have the cooling system checked by your SUBARU dealer.

If the frequent addition of coolant is necessary between vehicle service visits, it is recommended that you have your vehicle inspected by an authorized SUBARU dealer to check for leaks, da-

mage, or looseness.

■ **Engine coolant**

▼ **Checking the coolant level**

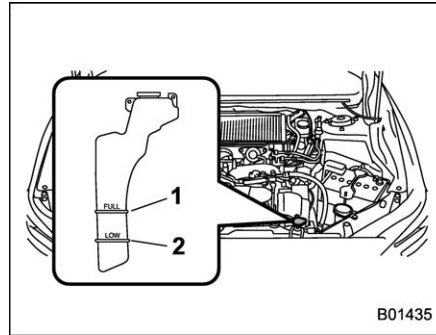

- 1) "FULL" level mark
- 2) "LOW" level mark

Check the coolant level at each fuel stop.

1. Check the coolant level on the outside of the reservoir while the engine is cool.
2. If the level is close to or lower than the "LOW" level mark, add coolant up to the "FULL" level mark. If the reserve tank is empty, remove the radiator cap and refill coolant up to just below the filler neck as shown in the following illustration.

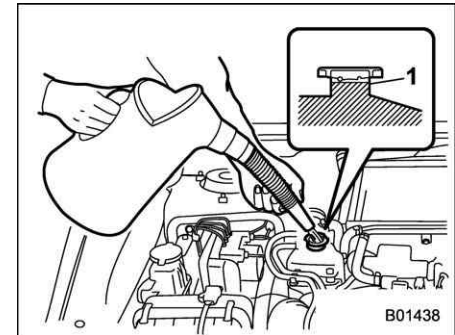

**STI**

- 1) Fill up to this level

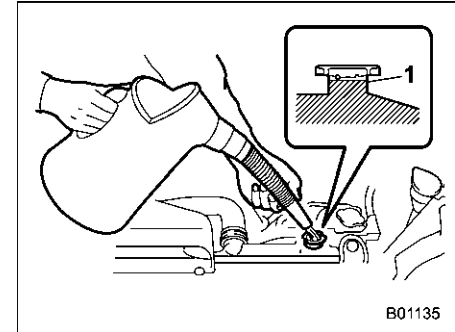

**Except STI**

- 1) Fill up to this level

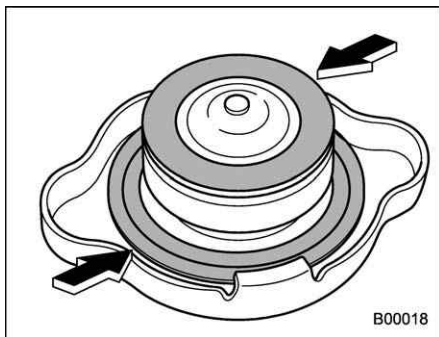

3. After refilling the reserve tank and the radiator, reinstall the cap and check that the rubber gaskets inside the radiator cap are in the proper position.

**CAUTION**

- Be careful not to spill engine coolant when adding it. If coolant touches the exhaust pipe, it may cause a bad smell, smoke, and/or a fire. If engine coolant gets on the exhaust pipe, be sure to wipe it off.
- Do not splash the engine coolant over painted parts. The alcohol contained in the engine coolant may damage the paint surface.

▼ **Changing the coolant**

It may be difficult to change the coolant. Have the coolant changed by your SUBARU dealer if necessary.

Have the coolant changed according to the maintenance schedule in the "Warranty and Maintenance Booklet".

**Air cleaner element**

**WARNING**

**Do not operate the engine with the air cleaner element removed. The air cleaner element not only filters intake air but also stops flames if the engine backfires. If the air cleaner element is not installed when the engine backfires, you could be burned.**

**CAUTION**

**When replacing the air cleaner element, use a genuine SUBARU air cleaner element. If it is not used, there is the possibility of causing a negative effect to the engine.**

The air cleaner element functions as a filter screen. When the element is perforated or removed, engine wear will be excessive and engine life shortened.

It is not necessary to clean or wash the air cleaner element.

## ■ Replacing the air cleaner element

Replace the air cleaner element according to the maintenance schedule in the "Warranty and Maintenance Booklet". Under extremely dusty conditions, replace it more frequently. It is recommended that you always use genuine SUBARU parts.

### ▼ STI

#### NOTE

It may be difficult to replace the air cleaner element. Have the air cleaner element replaced by your SUBARU dealer if necessary.

### ▼ Except STI

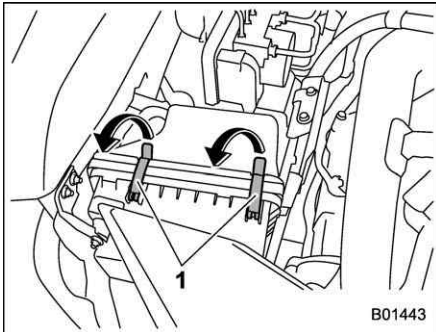

1) Clips

1. Unsnap the two clips holding the air cleaner case cover.

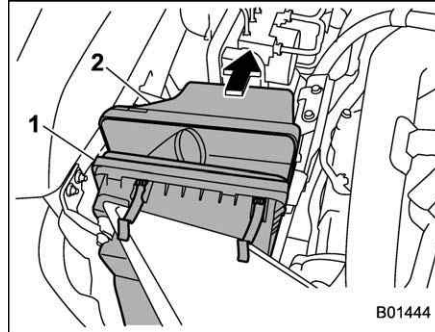

- 1) Air cleaner case
- 2) Air cleaner case cover

2. Open the air cleaner case and pull the cover rearward while lifting it up.

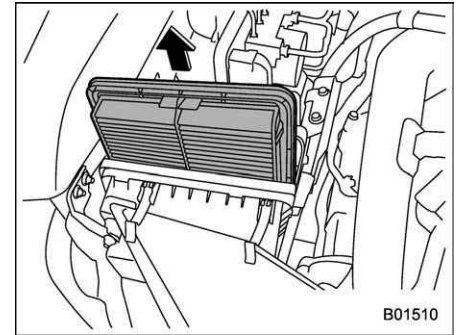

3. Remove the air cleaner element.
4. Clean the inside of the air cleaner case and case cover with a damp cloth and install a new air cleaner element.

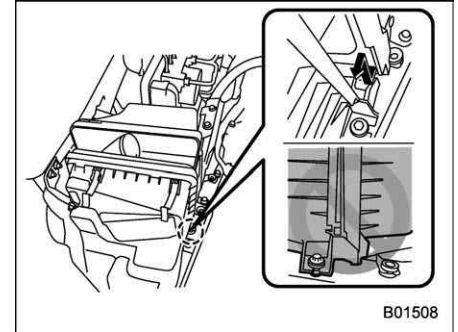

5. To install the air cleaner case cover, insert the projections on the air cleaner

case cover into the slits on the air cleaner case. The illustration above shows an example in which the projections are not fitted into the slits correctly.

6. Install in the reverse order of removal.

## **Spark plugs**

---

It may be difficult to replace the spark plugs. It is recommended that you have the spark plugs replaced by your SUBARU dealer.

Have the spark plugs replaced according to the maintenance schedule in the “Warranty and Maintenance Booklet”.

### **■ Recommended spark plugs**

For the recommended spark plugs, refer to “Electrical system” 12-8.

## **Drive belts**

---

### **NOTE**

**For models except STI, it is unnecessary to check the deflection of the drive belt periodically because this engine is equipped with an automatic belt tension adjuster. However, have the belt replaced according to the maintenance schedule in the “Warranty and Maintenance Booklet”. Consult your SUBARU dealer for replacement.**

**If the drive belt is loose, cracked or worn, contact your SUBARU dealer.**

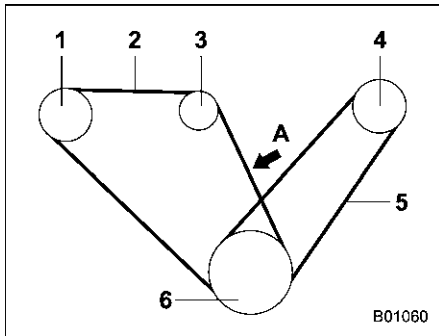
**STI**

- 1) Power steering oil pump pulley
  - 2) Front side belt
  - 3) Alternator pulley
  - 4) Air conditioner compressor pulley
  - 5) Rear side belt
  - 6) Crank pulley
- A) 22 lbf (98 N, 10 kgf)

**CAUTION**

**The front side belt, which runs in conjunction with the following components, must be used within the specified deflection.**

- **Power steering oil pump pulley**
- **Alternator pulley**
- **Crank pulley**

**Check the deflection of the front side**

**belt and if there is any looseness, cracks, wear or unusual noise on the front side belt, contact your SUBARU dealer.**

**Continuing to use the vehicle with the belt outside of the specification may cause the engine to malfunction and the above components to malfunction.**

To check the deflection of the front side belt, place a straightedge (ruler) across two adjacent pulleys (alternator pulley and crank pulley) and apply a force of 22 lbf (98 N, 10 kgf) midway between the pulleys by using a spring scale. The belt deflection should be the amount specified. If the front side belt is loose, cracked or worn, contact your SUBARU dealer.

in (mm)

	Deflection	
	New belt	Used belt
A	0.28 – 0.35 (7.0 – 9.0)	0.35 – 0.43 (9.0 – 11.0)

The rear side belt is a stretch-type belt, therefore the deflection does not need to be checked. If there are cracks or wear confirmed on the belts and a squeaking noise is heard from them, contact your SUBARU dealer.

## Manual transmission oil

It is not necessary to check the transmission oil level. Check that there are no cracks, damage or leakage. However, have the oil inspected by your SUBARU dealer according to the maintenance schedule in the “Warranty and Maintenance Booklet”. Consult your SUBARU dealer for details.

### ■ Recommended grade and viscosity

Each oil manufacturer has its own base oils and additives. Never use different brands together. For details, refer to “Manual transmission, front differential and rear differential gear oil” 12-6.

## Continuously variable transmission fluid

It is not necessary to check the transmission fluid level. Check that there are no cracks, damage or leakage. However, have the fluid inspected by your SUBARU dealer according to the maintenance schedule in the “Warranty and Maintenance Booklet”. Consult your SUBARU dealer for details.

## Front differential gear oil (CVT models) and rear differential gear oil

It is not necessary to check the gear oil level. Check that there are no cracks, damage or leakage. However, have the oil inspected by your SUBARU dealer according to the maintenance schedule in the “Warranty and Maintenance Booklet”. Consult your SUBARU dealer for details.

### ■ Recommended grade and viscosity

Each oil manufacturer has its own base oils and additives. Never use different brands together. For details, refer to “Manual transmission, front differential and rear differential gear oil” 12-6.



### CAUTION

**Using a differential gear oil other than the specified oil may cause a decline in vehicle performance.**

## Power steering fluid (STI)

### ■ Checking the fluid level

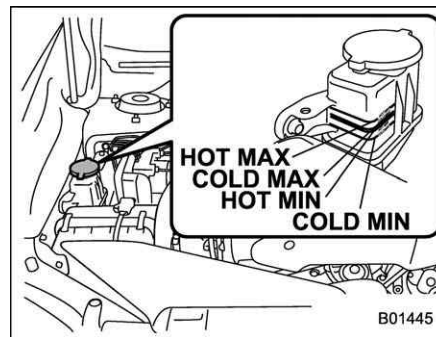

The power steering fluid expands greatly as its temperature rises; the fluid level differs according to fluid temperature. Therefore, the reservoir tank has two different checking ranges for hot and cold fluids.

Check the power steering fluid level monthly.

1. Park the vehicle on a level surface, and stop the engine.
2. Check the fluid level of the reservoir tank.

When the fluid is hot after the vehicle has been run: Check that the oil level is between “HOT MIN” and “HOT MAX” on

the surface of the reservoir tank.

When the fluid is cool before the vehicle is run: Check that the oil level is between "COLD MIN" and "COLD MAX" on the surface of the reservoir tank.

3. If the fluid level is lower than the applicable "MIN" line, add the recommended fluid as necessary to bring the level between the "MIN" and "MAX" line.

If the fluid level is extremely low, it may indicate possible leakage. Consult your SUBARU dealer for an inspection.



#### WARNING

Be careful not to burn yourself because the fluid may be hot.



#### CAUTION

- When you add power steering fluid, use only clean fluid, and be careful not to allow any dirt into the tank. And never use different brands together.
- Be careful not to spill power steering fluid when adding it. If power steering fluid touches the exhaust pipe, it may cause a bad smell, smoke, and/or a fire. If power steering fluid gets on the

exhaust pipe, be sure to wipe it off.

#### ■ Recommended fluid

Refer to "Fluids" 12-7.

## Brake fluid

### ■ Checking the fluid level



#### WARNING

- Never let brake fluid contact your eyes because brake fluid can be harmful to your eyes. If brake fluid gets in your eyes, immediately flush them thoroughly with clean water. For safety, when performing this work, wearing eye protection is advisable.
- Brake fluid absorbs moisture from the air. Any absorbed moisture can cause a dangerous loss of braking performance.
- If the vehicle requires frequent refilling, there may be a leak. If you suspect a problem, have the vehicle checked at your SUBARU dealer.



#### CAUTION

- When adding brake fluid, be careful not to allow any dirt into the reservoir.
- Never splash the brake fluid over painted surfaces or rubber parts.

Alcohol contained in the brake fluid may damage them.

- Be careful not to spill brake fluid when adding it. If brake fluid touches the exhaust pipe, it may cause a bad smell, smoke, and/or a fire. If brake fluid gets on the exhaust pipe, be sure to wipe it off.

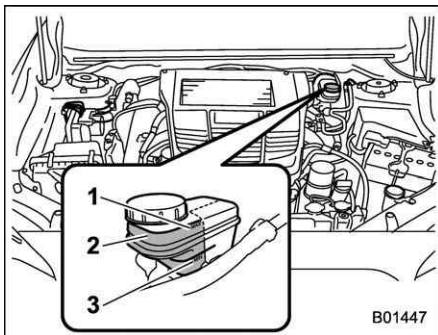

- 1) "MAX" level line
- 2) Check the brake fluid level in this area.
- 3) "MIN" level line

Check the fluid level monthly.

Check the fluid level on the outside of the reservoir. Because this reservoir is used for both the brake and clutch systems and has chambers for each system, be sure to check the fluid level for the brake system at

the front part of the reservoir (shaded area in the illustration). If the fluid level is below "MIN", add the recommended brake fluid to "MAX".

Use only brake fluid from a sealed container.

### ■ Recommended brake fluid

Refer to "Fluids" 12-7.

#### ⚠ CAUTION

Never use different brands of brake fluid together. Also, avoid mixing DOT 3 and DOT 4 brake fluids even if they are the same brand.

## Clutch fluid (MT models)

### ■ Checking the fluid level

#### ⚠ WARNING

Never let clutch fluid contact your eyes because clutch fluid can be harmful to your eyes. If clutch fluid gets in your eyes, immediately flush them thoroughly with clean water. For safety, when performing this work, wearing eye protection is advisable.

#### ⚠ CAUTION

- Clutch fluid absorbs moisture from the air. Any absorbed moisture can cause improper clutch operation.
- If the vehicle requires frequent refilling, there may be a leak. If you suspect a problem, have the vehicle checked at your SUBARU dealer.
- When you add clutch fluid, be careful not to allow any dirt into the tank.
- Never splash the clutch fluid over painted surfaces or rubber parts.



Alcohol contained in the clutch fluid may damage them.

- **Be careful not to spill clutch fluid when adding it. If clutch fluid touches the exhaust pipe, it may cause a bad smell, smoke, and/or a fire. If clutch fluid gets on the exhaust pipe, be sure to wipe it off.**
- **Check the fluid level for the clutch system at the inboard side of the reservoir. You cannot check the fluid level at the outboard side of the reservoir.**

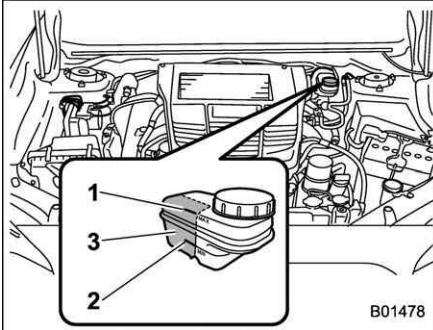

- 1) "MAX" level line
- 2) "MIN" level line
- 3) Check the clutch fluid level in this area.

Check the fluid level monthly.

Check the fluid level on the outside of the reservoir. Because this reservoir is used for both the brake and clutch systems and has chambers for each system, be sure to check the fluid level for the clutch system at the **inboard side of the reservoir** (shaded area in the illustration). If the fluid level is below "MIN", add the recommended clutch fluid to "MAX".

Use only clutch fluid from a sealed container.

### ■ Recommended clutch fluid

Refer to "Fluids" 12-7.

#### ▲ CAUTION

**Never use different brands of clutch fluid together. Also, avoid mixing DOT 3 and DOT 4 brake fluids even if they are the same brand.**

## Brake booster

If the brake booster does not operate as described in the following, have it checked by your SUBARU dealer.

1. With the engine off, depress the brake pedal several times, applying the same pedal force each time. The distance the pedal travels should not vary.
2. With the brake pedal depressed, start the engine. The pedal should move slightly down to the floor.
3. With the brake pedal depressed, stop the engine and keep the pedal depressed for 30 seconds. The pedal height should not change.
4. Start the engine again and run for approximately one minute then turn it off. Depress the brake pedal several times to check the brake booster. The brake booster operates properly if the pedal stroke decreases with each depression.

### NOTE

**When you depress the brake pedal strongly or suddenly, you might feel that lighter depression of the brake pedal generates a greater braking force. However, even though these occur, they do not indicate any malfunctions, and the brake assist system**

is operating properly.

**Brake assist is not a system that brings more braking ability to the vehicle beyond its breaking capability.**

## Brake pedal

Check the brake pedal free play and reserve distance according to the maintenance schedule in the "Warranty and Maintenance Booklet".

### ■ Checking the brake pedal free play

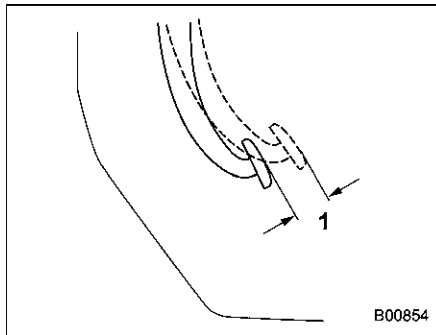

1) 0.02 – 0.11 in (0.5 – 2.7 mm)

Stop the engine and firmly depress the brake pedal several times. Lightly pull the brake pedal up with one finger to check the free play with a force of less than 2 lbf (10 N, 1 kgf).

If the free play is not within proper specification, contact your SUBARU dealer.

### ■ Checking the brake pedal reserve distance

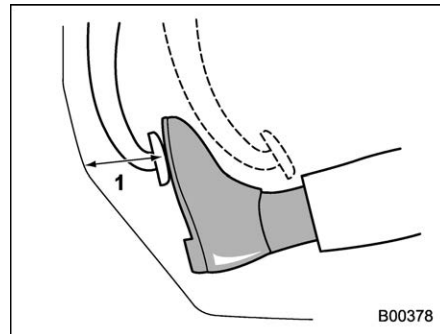

1) More than 2.56 in (65 mm)

Depress the pedal with a force of approximately 66 lbf (294 N, 30 kgf) and measure the distance between the upper surface of the pedal pad and the floor.

When the measurement is smaller than the specification, or when the pedal does not operate smoothly, contact with your SUBARU dealer.

## Clutch pedal (MT models)

Check the clutch pedal free play according to the maintenance schedule in the "Warranty and Maintenance Booklet".

### ■ Checking the clutch function

Check the clutch engagement and disengagement.

1. With the engine idling, check that there are no abnormal noises when the clutch pedal is depressed, and that shifting into 1st or reverse feels smooth.
2. Start the vehicle by releasing the pedal slowly to check that the engine and transmission smoothly couple without any sign of slippage.

### ■ Checking the clutch pedal free play

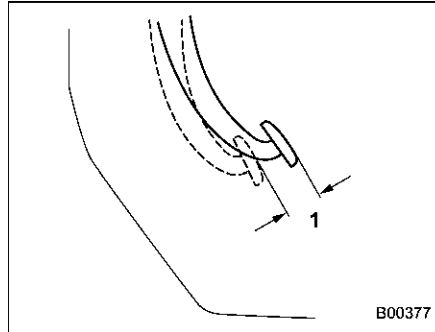

1) 0.16 – 0.43 in (4.0 – 11.0 mm)

Lightly depress the clutch pedal down with your finger until you feel resistance, and check the free play.

If the free play is not within proper specification, contact your SUBARU dealer.

## Hill start assist system

Ensure that the Hill start assist system operates properly under the following circumstances.

1. Stop the vehicle on an uphill grade by depressing the brake pedal (all models) and clutch pedal (MT models only), with the engine running.
2. Make sure that the vehicle does not move backward for several seconds after the brake pedal is released.
3. Then make sure the vehicle starts climbing the grade by following the normal starting procedures.

If the Hill start assist system does not operate as described above, contact your SUBARU dealer.

## Replacement of brake pad and lining

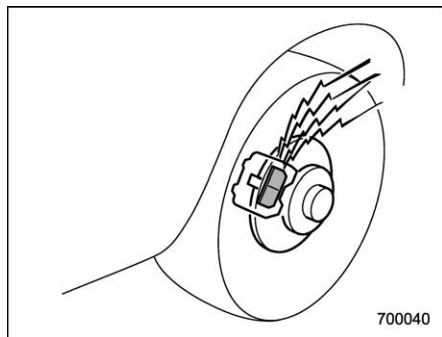

The disc brakes have audible wear indicators on the brake pads. If the brake pads wear close to their service limit, the wear indicator makes a very audible scraping noise when the brake pedal is applied.

If you hear this scraping noise each time you apply the brake pedal, have the brake pads serviced by your SUBARU dealer as soon as possible.



### CAUTION

- It is recommended that you disconnect the vehicle battery before replacing the brake pad. However, it is dangerous to disconnect the vehicle battery. We recommend that you have your SUBARU dealer replace the brake pad.
- If you continue to drive despite the scraping noise from the audible brake pad wear indicator, it will result in the need for costly brake rotor repair or replacement.

### ■ Breaking-in of new brake pads (models with electronic parking brake system)

When replacing the brake pad, use only genuine SUBARU parts. After replacement, break in the new parts as follows.

#### ▼ Brake pad

While maintaining a speed of 30 to 40 mph (50 to 65 km/h), step on the brake pedal lightly. Repeat this five or more times. Also, apply and release the electronic parking brake five or more times.

### ■ Breaking-in of new brake pads and linings (models without electronic parking brake system)

When replacing the brake pad or lining, use only genuine SUBARU parts. After replacement, break in the new parts as follows.

#### ▼ Brake pad and lining

While maintaining a speed of 30 to 40 mph (50 to 65 km/h), step on the brake pedal lightly. Repeat this five or more times.

#### ▼ Parking brake lining

1. Drive the vehicle at a speed of approximately 22 mph (35 km/h).
2. With the parking brake release button pushed in, pull the parking brake lever SLOWLY and GENTLY (pulling with a force of approximately 33.7 lbf [150 N, 15.3 kgf]).
3. Drive the vehicle for approximately 220 yards (200 meters) in this condition.
4. Wait 5 to 10 minutes for the parking brake to cool down. Repeat this procedure.
5. Check the parking brake stroke. If the parking brake stroke is out of the specified range, adjust it by turning the adjusting nut located on the parking brake lever.

Parking brake stroke:

7 – 8 notches / 45 lbf (200 N, 20.4 kgf)



### WARNING

Select a safe location and situation for break-in driving.



### CAUTION

Pulling the parking brake lever too forcefully may cause the rear wheels to lock. To avoid this, be certain to pull the lever up slowly and gently.

## Parking brake stroke (models without electronic parking brake system)

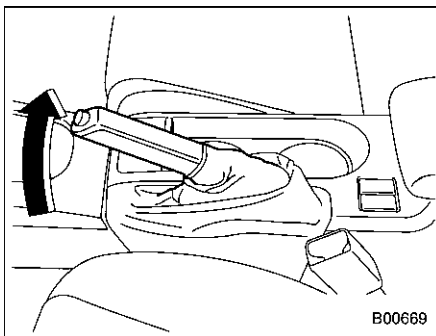

Check the parking brake stroke according to the maintenance schedule in the “Warranty and Maintenance Booklet”.

When the parking brake is properly adjusted, braking power is fully applied by pulling the lever up 7 to 8 notches gently but firmly (approximately 45 lbf [200 N, 20.4 kgf]). If the parking brake lever stroke is not within the specified range, have the brake system checked and adjusted at your SUBARU dealer.

## Tires and wheels

### ■ Types of tires

You should be familiar with type of tires present on your vehicle.

#### ▼ All season tires

All season tires are designed to provide an adequate measure of traction, handling and braking performance in year-round driving including snowy and icy road conditions. However, all season tires do not offer as much traction performance as winter (snow) tires in heavy or loose snow or on icy roads.

All season tires are identified by “ALL SEASON” and/or “M+S” (Mud & Snow) on the tire sidewall.

#### ▼ Summer tires

Summer tires are high-speed capability tires best suited for highway driving under dry conditions.

Summer tires are inadequate for driving on slippery roads such as on snow-covered or icy roads.

If you drive your vehicle on snow-covered or icy roads, we strongly recommend the use of winter (snow) tires.

When installing winter tires, be sure to replace all four tires.

**NOTE**

These tires will wear more rapidly than normal passenger car tires.

▼ **Winter (snow) tires**

Winter tires are best suited for driving on snow-covered and icy roads. However, winter tires do not perform as well as summer tires and all season tires on roads other than snow-covered and icy roads.

■ **Tire pressure monitoring system (TPMS) (if equipped)**

The tire pressure monitoring system provides the driver with a warning message by sending a signal from a sensor that is installed in each wheel when tire pressure is severely low. The tire pressure monitoring system will activate only when the vehicle is driven. Also, this system may not react immediately to a sudden drop in tire pressure (for example, a blow-out caused by running over a sharp object).

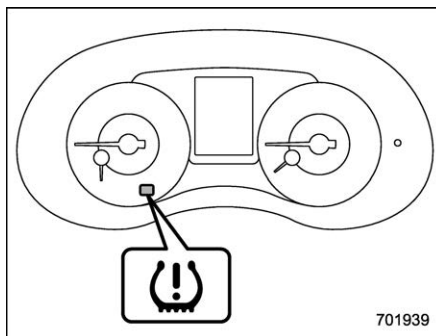

**Low tire pressure warning light**

If you adjust the tire pressures in a warm garage and will then drive the vehicle in cold outside air, the resulting drop in tire pressures may cause the low tire pressure warning light to illuminate. To avoid this problem when adjusting the tire pressures in a warm garage, inflate the tires to pressures higher than those shown on the tire inflation pressure label. Specifically, inflate them by an extra 1 psi (6.9 kPa, 0.07 kgf/cm<sup>2</sup>) for every difference of 10°F (5.6°C) between the temperature in the garage and the temperature outside. By way of example, the following table shows the required tire pressures that correspond to various outside temperatures when the temperature in the garage is 60°F (15.6°C).

**Example:**

Tire size: 245/40R18 97W

Standard tire pressures:

Front: 33 psi (230 kPa, 2.3 kgf/cm<sup>2</sup>)

Rear: 32 psi (220 kPa, 2.2 kgf/cm<sup>2</sup>)

Garage temperature: 60°F (15.6°C)

Outside temperature	Adjusted pressure [psi (kPa, kgf/cm <sup>2</sup> )]	
	Front	Rear
30°F (-1°C)	36 (250, 2.5)	35 (240, 2.4)
10°F (-12°C)	38 (260, 2.6)	37 (255, 2.55)
-10°F (-23°C)	40 (275, 2.75)	39 (270, 2.7)

If the low tire pressure warning light illuminates when you drive the vehicle in cold outside air after adjusting the tire pressures in a warm garage, re-adjust the tire pressures using the method described above. Then, increase the vehicle speed to at least 20 mph (32 km/h) and check to see that the low tire pressure warning light turns off a few minutes later. If the low tire pressure warning light does not turn off, the tire pressure monitoring system may not be functioning normally. In this event, go to a SUBARU dealer to have the system inspected as soon as possible.

While the vehicle is driven, friction between tires and the road surface causes the tires to warm up. After illumination of

the low tire pressure warning light, any increase in the tire pressures caused by an increase in the outside air temperature or by an increase in the temperature in the tires can cause the low tire pressure warning light to turn off.

System resetting is necessary when the wheels are changed (for example, a switch to snow tires) and new TPMS valves are installed on the newly fitted wheels. Have this work performed by a SUBARU dealer following wheel replacement.

It may not be possible to install TPMS valves on certain wheels that are on the market. Therefore, if you change the wheels (for example, a switch to snow tires), use wheels that have the same part number as the standard-equipment wheels. Without four operational TPMS valve/sensors on the wheels, the TPMS will not fully function and the warning light on the combination meter will illuminate steadily after blinking for approximately one minute.

When a tire is replaced, adjustments are necessary to ensure continued normal operation of the tire pressure monitoring system. As with wheel replacement, therefore, you should have the work performed by a SUBARU dealer.

 **WARNING**

**If the low tire pressure warning light does not illuminate briefly after the ignition switch is turned ON or the light illuminates steadily after blinking for approximately one minute, you should have your Tire Pressure Monitoring System checked at a SUBARU dealer as soon as possible.**

**If this light illuminates while driving, never brake suddenly. Instead, perform the following procedure. Otherwise an accident involving serious vehicle damage and serious personal injury could occur.**

- 1) Keep driving straight ahead while gradually reducing speed.**
- 2) Slowly pull off the road to a safe place.**

**If this light still illuminates while driving after adjusting the tire pressure, a tire may have significant damage and a fast leak that causes the tire to lose air rapidly. If you have a flat tire, refer to "Flat tires" 9-4.**

**When a spare tire is mounted or a wheel rim is replaced without the original pressure sensor/transmitter being transferred, the low tire pres-**

**sure warning light will illuminate steadily after blinking for approximately one minute. This indicates the TPMS is unable to monitor all four road wheels. Contact your SUBARU dealer as soon as possible for tire and sensor replacement and/or system resetting. If the light illuminates steadily after blinking for approximately one minute, promptly contact a SUBARU dealer to have the system inspected.**

**■ Tire inspection**

Check on a daily basis that the tires are free from serious damage, nails, and stones. At the same time, check the tires for abnormal wear. Contact your SUBARU dealer immediately if you find any problem.

**NOTE**

- When the wheels and tires strike curbs or are subjected to harsh treatment as when the vehicle is driven on a rough surface, they can suffer damage that cannot be seen with the naked eye. This type of damage**

does not become evident until time has passed. Try not to drive over curbs, potholes or on other rough surfaces. If doing so is unavoidable, keep the vehicle's speed down to a walking pace or less, and approach the curbs as squarely as possible. Also, make sure the tires are not pressed against the curb when you park the vehicle.

- If you feel unusual vibration while driving or find it difficult to steer the vehicle in a straight line, one of the tires and/or wheels may be damaged. Drive slowly to the nearest authorized SUBARU dealer and have the vehicle inspected.

### ■ Tire pressures and wear

Maintaining the correct tire pressures helps to maximize the tires' service lives and is essential for good running performance. Check and, if necessary, adjust the pressure of each tire and the spare (if

equipped) at least once a month and before any long journey.

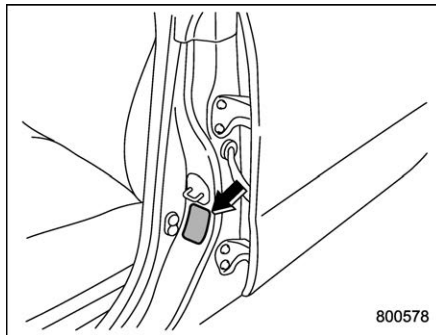

### Tire inflation pressure label

Check the tire pressures when the tires are cold. Use a pressure gauge to adjust the tire pressures to the values shown on the tire inflation pressure label. The tire inflation pressure label is located on the door pillar on the driver's side.

Driving even a short distance warms up the tires and increases the tire pressures. Also, the tire pressures are affected by the out-

side temperature. It is best to check tire pressure outdoors before driving the vehicle.

When a tire becomes warm, the air inside it expands, causing the tire pressure to increase. Be careful not to mistakenly release air from a warm tire to reduce its pressure.

### NOTE

- The air pressure in a tire increases by approximately 4.3 psi (30 kPa, 0.3 kgf/cm<sup>2</sup>) when the tire becomes warm.
- The tires are considered cold when you have parked the vehicle for at least three hours or have driven less than one mile (1.6 km).



**WARNING**

**Do not let air out of warm tires to adjust pressure. Doing so will result in low tire pressure.**



Incorrect tire pressures detract from controllability and ride comfort, and they cause the tires to wear abnormally.

- Correct tire pressure (tread worn evenly)

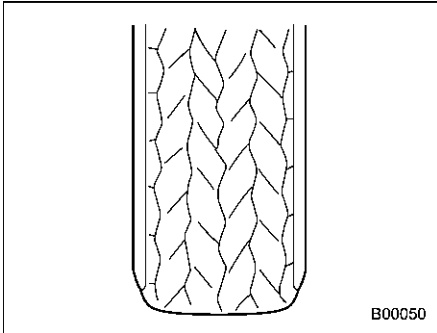

Roadholding is good, and steering is responsive. Rolling resistance is low, so fuel consumption is also lower.

- Under inflated tire (tread worn on shoulders)

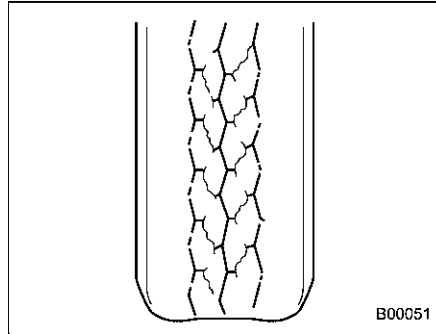

Rolling resistance is high, so fuel consumption is also higher.

- Over inflated tire (tread worn in the center)

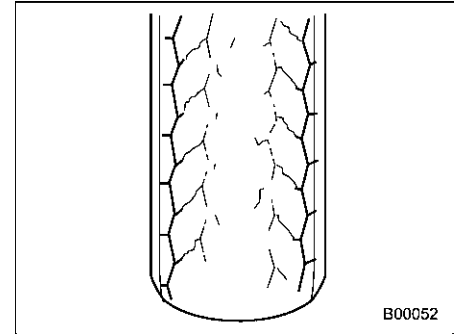

Ride comfort is poor. Also, the tire magnifies the effects of road-surface bumps and dips, possibly resulting in vehicle damage.

If the tire inflation pressure label shows tire pressures for the vehicle when fully loaded, adjust the tire pressures to the values that match the loading conditions.

**⚠ WARNING**

Driving at high speeds with excessively low tire pressures can cause the tires to deform severely and to rapidly heat up. A sharp increase in temperature could cause tread separation, and destruction of the tires. The resulting loss of vehicle control could lead to an accident.

**■ Wheel balance**

Each wheel was correctly balanced when your vehicle was new, but the wheels will become unbalanced as the tires become worn during use. Wheel imbalance causes the steering wheel to vibrate slightly at certain vehicle speeds and detracts from the vehicle's straight-line stability. It can also cause steering and suspension system problems and abnormal tire wear. If you suspect that the wheels are not correctly balanced, have them checked and

adjusted by your SUBARU dealer. Also have them adjusted after tire repairs and after tire rotation.

**⚠ CAUTION**

Loss of correct wheel alignment causes the tires to wear on one side and reduces the vehicle's running stability. Contact your SUBARU dealer if you notice abnormal tire wear.

**NOTE**

The suspension system is designed to hold each wheel at a certain alignment (relative to the other wheels and to the road) for optimum straight-line stability and cornering performance.

**■ Wear indicators**

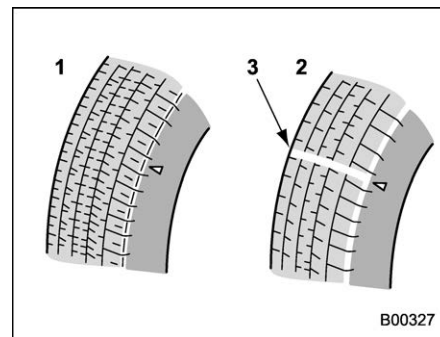

- 1) New tread
- 2) Worn tread
- 3) Tread wear indicator

Each tire incorporates a tread wear indicator, which becomes visible when the depth of the tread grooves decreases to 0.063 in (1.6 mm). Replace the tire when the tread wear indicator appears as a solid band across the tread.

**WARNING**

When a tire's tread wear indicator becomes visible, the tire is worn beyond the acceptable limit and you must replace it immediately. With a tire in this condition, driving at high speeds in wet weather can cause the vehicle to hydroplane. The resulting loss of vehicle control can lead to an accident.

**NOTE**

For safety, inspect tire tread regularly and replace the tires before their tread wear indicators become visible.

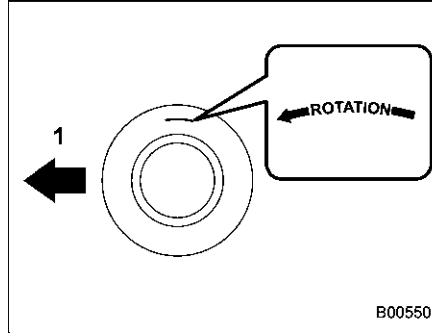
**■ Rotational direction of tires****Example of rotational direction marked on the sidewall**

1) Front

If the tires have specific rotational direction, refer to the arrow marked on the side wall.

The arrow should be pointing forward when the wheels are fitted.

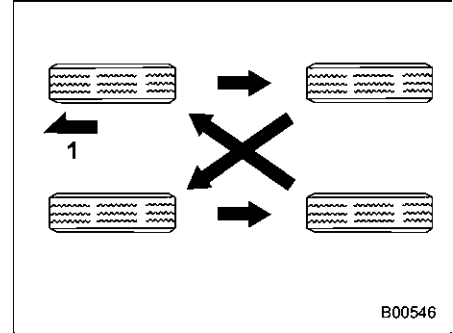
**■ Tire rotation****Vehicles equipped with 4 non-unidirectional tires**

1) Front

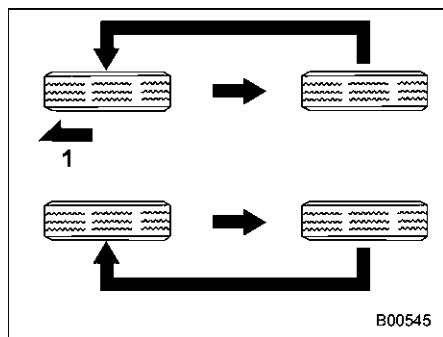

### Vehicles equipped with unidirectional tires

#### 1) Front

Tire wear varies from wheel to wheel. Move the tires to the positions shown in the illustration each time they are rotated. For the tire rotation schedule, refer to the “Warranty and Maintenance Booklet”.

Replace any damaged or unevenly worn tires at the time of rotation. After tire rotation, adjust the tires pressures and make sure the wheel nuts are correctly tightened.

After driving approximately 600

miles (1,000 km), check the wheel nuts again and retighten any nut that has become loose.

### ■ Tire replacement

The wheels and tires are important and integral parts of your vehicle’s design; they cannot be changed arbitrarily. The tires fitted as standard equipment are optimally matched to the characteristics of the vehicle and were selected to give the best possible combination of running performance, ride comfort, and service life. It is essential for every tire to have a size and construction matching those shown on the tire inflation pressure label and to have a speed symbol and load index matching those shown on the tire inflation pressure label.

Using tires of a non-specified size detracts from controllability, ride comfort, braking performance, speedometer accuracy and odometer accuracy. It also creates incorrect body-to-tire clearances and inappropriately changes the vehicle’s ground clearance.

All four tires must be the same in terms of manufacturer, brand (tread pattern), construction, and size. You are advised to replace the tires with new ones that are

identical to those fitted as standard equipment.

For safe vehicle operation, SUBARU recommends replacing all four tires at the same time.

 **WARNING**

- **When replacing or installing tire(s), all four tires must be the same for the following items.**
  - (a) Size
  - (b) Speed symbol
  - (c) Load index
  - (d) Circumference
  - (e) Construction
  - (f) Manufacturer
  - (g) Brand (tread pattern)
  - (h) Degrees of wear

**For items (a) to (c), you must obey the specification that is printed on the tire inflation pressure label. The tire inflation pressure label is located on the driver’s door pillar.**

**If all four tires are not the same for items (a) to (h), serious mechanical damage could be**

caused to the drivetrain of the car, and affect the followings.

- Ride
- Handling
- Braking
- Speedometer/Odometer calibration
- Clearance between the body and the tires

It also may be dangerous and lead to loss of vehicle control, and it can lead to an accident.

- Use only radial tires. Do not use radial tires together with belted bias tires and/or bias-ply tires. Doing so can dangerously reduce controllability, resulting in an accident.

## ■ Wheel replacement

When replacing wheels due, for example, to damage, make sure the replacement wheels match the specifications of the wheels that are fitted as standard equipment. Replacement wheels are available from SUBARU dealers.



### WARNING

Use only those wheels that are specified for your vehicle. Wheels not meeting specifications could interfere with brake caliper operation and may cause the tires to rub against the wheel well housing during turns. The resulting loss of vehicle control could lead to an accident.

### NOTE

- When any of the wheels are removed and replaced for tire rotation or to change a flat tire, always check the tightness of the wheel nuts after driving approximately 600 miles (1,000 km). If any nut is loose, tighten it to the specified torque.

## Alloy wheels

Alloy wheels can be scratched and damaged easily. Handle them carefully to maintain their appearance, performance, and safety.

- When any of the wheels are removed and replaced for tire rotation or to change a flat tire, always check the tightness of the wheel nuts after driving approximately 600 miles (1,000 km). If any nut is loose, tighten it to the specified torque.
- Never apply oil to the threaded parts, wheel nuts, or tapered surface of the wheel.
- Never let the wheel rub against sharp protrusions or curbs.
- When wheel nuts, balance weights, or the center cap is replaced, be sure to replace them with genuine SUBARU parts designed for alloy wheels.

## Windshield washer fluid

### CAUTION

Never use engine coolant as washer fluid because it could cause paint damage.

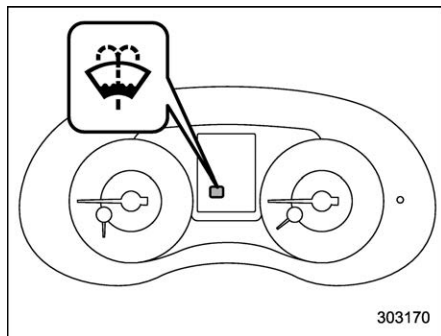

### Windshield washer fluid warning indicator

When there is only a small amount of washer fluid remaining, the windshield washer fluid warning indicator will illuminate. When this occurs, refill the washer fluid as follows.

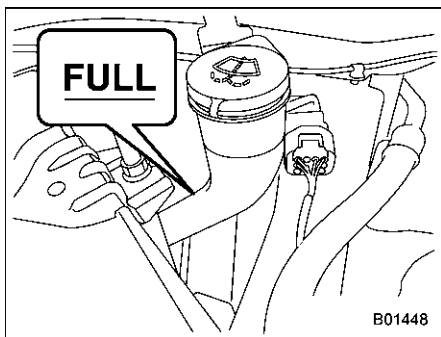

Remove the washer tank filler cap, then add windshield washer fluid until it reaches the "FULL" mark on the tank. If windshield washer fluid is unavailable use clean water.

In areas where water freezes in winter, use an anti-freeze type windshield washer fluid.

If you fill the reservoir tank with a fluid with a different concentration from the one used previously, purge the old fluid from the piping between the reservoir tank and washer nozzles by operating the washer for a certain period of time. Otherwise, if the concentration of the fluid remaining in the piping is too low for the outside temperature, it may freeze and block the nozzles.

### CAUTION

- Adjust the washer fluid concentration appropriately for the outside temperature. If the concentration is inappropriate, sprayed washer fluid may freeze on the windshield and obstruct your view, and the fluid may freeze in the reservoir tank.
- Be careful foreign matter does not contaminate the washer fluid when filling the tank. Contamination could cause malfunctions, such as clogging the pump.
- State or local regulations on volatile organic compounds may restrict the use of methanol, a common windshield washer anti-freeze additive. Use washer fluids containing non-methanol anti-freeze agents only if they provide cold weather protection without damaging your vehicle's paint, wiper blades or washer system.

## Replacement of wiper blades

Grease, wax, insects, or other material on the windshield or the wiper blade results in jerky wiper operation and streaking on the glass. If you cannot remove the streaks after operating the windshield washer or if the wiper operation is jerky, clean the outer surface of the windshield and the wiper blades using a sponge or soft cloth with a neutral detergent or mild-abrasive cleaner. After cleaning, rinse the windshield and wiper blades with clean water. The windshield is clean if beads do not form when you rinse the windshield with water.

### CAUTION

- Do not clean the wiper blades with gasoline or a solvent, such as paint thinner or benzine. This will cause deterioration of the wiper blades.
- When you are going to raise the passenger-side wiper arm, first raise the driver-side wiper arm. Otherwise, the passenger-side wiper assembly and driver-side wiper assembly will touch each other, possibly resulting in scratches.

- Return the passenger-side wiper arm to its original position before returning the driver-side wiper arm to its original position. Otherwise, the passenger-side wiper assembly and driver-side wiper assembly will touch each other, possibly resulting in scratches.
- While removing the wiper blades from the wiper arms, do not return the wiper arms to the original positions. Otherwise, the windshield surface may be scratched.
- When returning the raised wiper arms to the original positions, carefully return the wiper arms on the windshield by hand. You should not return the wiper arms to the windshield only by the return spring. Otherwise, the wiper arms may be deformed and/or the windshield surface may be scratched.

If you cannot eliminate the streaking even after following this method, replace the wiper blades using the following procedures.

## ■ Windshield wiper blade assembly

1. Raise the wiper arm off the windshield.

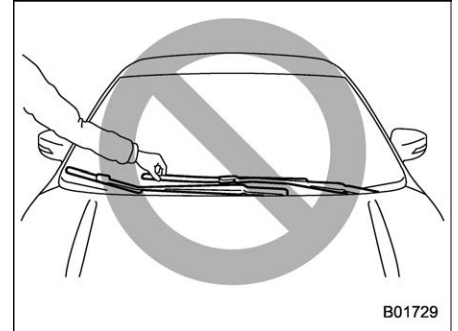

### CAUTION

Hold the wiper arm when replacing the wiper blade. Holding the wiper blade, may result in blade deformation.

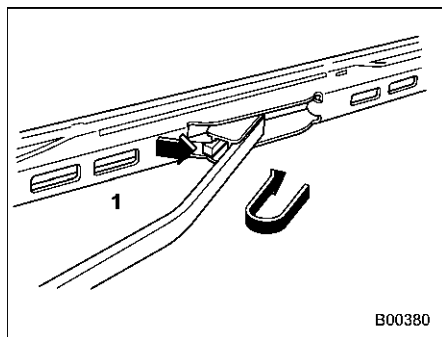

1) Stopper

2. Remove the wiper blade assembly by holding its pivot area and pushing it in the direction shown by the arrow while depressing the wiper blade stopper.

3. Install the wiper blade assembly to the wiper arm. Make sure that it locks in place.

4. Hold the wiper arm by hand and slowly lower it in position.

## ■ Windshield wiper blade rubber

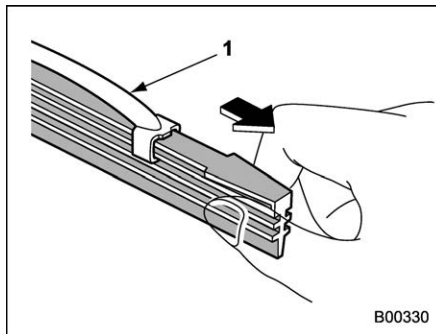

1) Metal support

1. Grasp the locked end of the blade rubber assembly and pull it firmly until the stoppers on the rubber are free of the metal support.

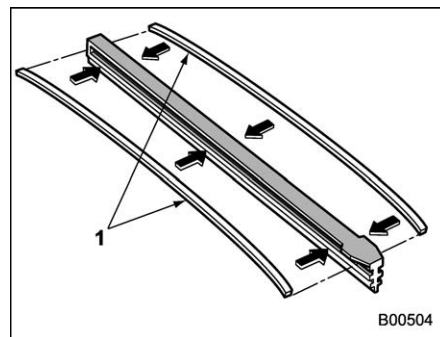

1) Metal spines

2. If the new blade rubber is not provided with two metal spines, remove the metal spines from the old blade rubber and install them in the new blade rubber.

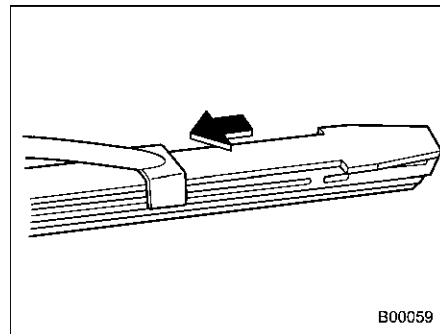

3. Align the claws of the metal support



with the grooves in the rubber and slide the blade rubber assembly into the metal support until it locks.

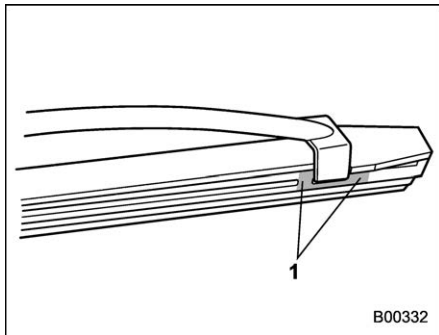

1) Stopper

4. Be sure to position the claws at the end of the metal support between the stoppers on the rubber as shown. If the rubber is not retained properly, the wiper blade may scratch the windshield.

## Battery

### ⚠ WARNING

- Before beginning work on or near any battery, be sure to extinguish all cigarettes, matches, and lighters. Never expose a battery to an open flame or electric sparks. Batteries give off a gas which is highly flammable and explosive.
- For safety, in case an explosion does occur, wear eye protection or shield your eyes when working near any battery. Never lean over a battery.
- Do not let battery fluid contact eyes, skin, fabrics, or paint because battery fluid is a corrosive acid. If battery fluid gets on your skin or in your eyes, immediately flush the area with water thoroughly. Seek medical help immediately if acid has entered the eyes.

If battery fluid is accidentally swallowed, immediately drink a large amount of milk or water, and seek medical attention immediately.

- To lessen the risk of sparks, remove rings, metal watchbands, and other metal jewelry. Never allow metal tools to contact the positive battery terminal and anything connected to it WHILE you are at the same time in contact with any other metallic portion of the vehicle because a short circuit will result.
- Keep everyone including children away from the battery.
- Charge the battery in a well-ventilated area.
- Battery posts, terminals and related accessories contain lead and lead compounds, chemicals known to the State of California to cause cancer and reproductive harm. Batteries also contain other chemicals known to the State of California to cause cancer. *Wash hands after handling.*

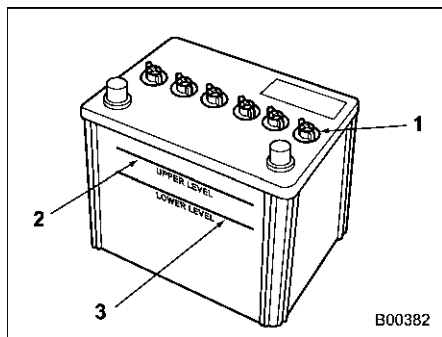

B00382

- 1) Cap
- 2) Upper level
- 3) Lower level

It is unnecessary to periodically check the battery fluid level or periodically refill with distilled water.

However, if the battery fluid level is below the lower level, remove the cap. Fill to the upper level with distilled water.

**CAUTION**

**Never use more than 10 amperes when charging the battery because it will shorten battery life.**

## Fuses

**CAUTION**

**Never replace a fuse with one having a higher rating or with material other than a fuse because serious damage or a fire could result.**

The fuses are designed to melt during an overload to prevent damage to the wiring harness and electrical equipment. The fuses are located in two fuse boxes.

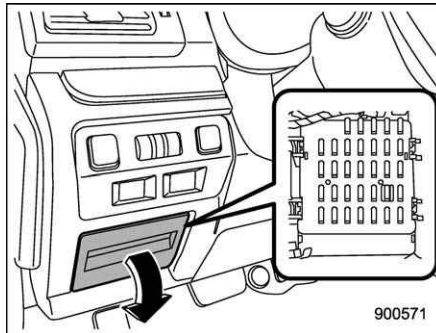

900571

One is located under the instrument panel behind the fuse box cover on the driver's seat side. To remove the cover, pull it out.

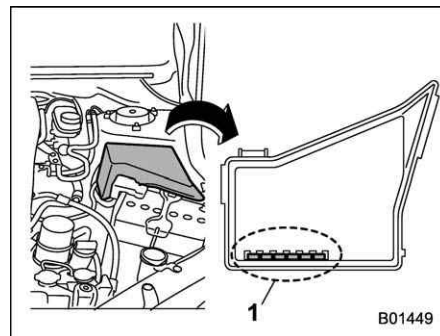

B01449

- 1) Spare fuses

The other one (main fuse box) is housed in the engine compartment. Also, the spare fuses are stored in the fuse box cover.

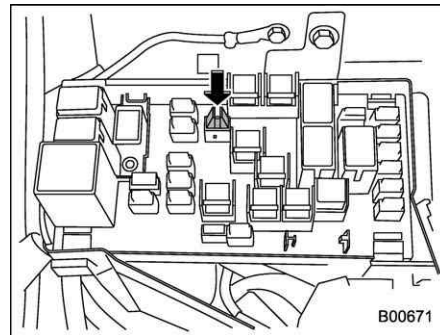

B00671

The fuse puller is stored in the main fuse box in the engine compartment.

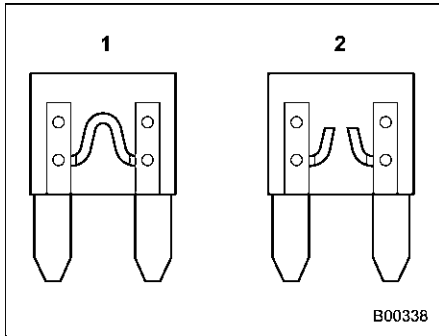

- 1) Good
- 2) Blown

If any lights, accessories or other electrical controls do not operate, inspect the corresponding fuse. If a fuse has blown, replace it.

1. Turn the ignition switch to the "LOCK"/"OFF" position and turn off all electrical accessories.
2. Remove the cover.
3. Determine which fuse may be blown. Look at the back side of each fuse box cover and refer to "Fuses and circuits" 12-10.

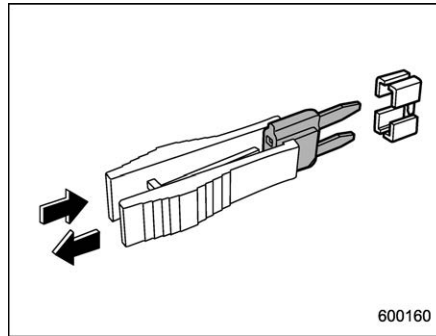

4. Pull out the fuse with the fuse puller.
5. Inspect the fuse. If it has blown, replace it with a spare fuse of the same rating.
6. If the same fuse blows again, this indicates that its system has a problem. Contact your SUBARU dealer for repairs.

## Installation of accessories

Always consult your SUBARU dealer before installing fog lights or any other electrical equipment in your vehicle. Such accessories may cause the electronic system to malfunction if they are incorrectly installed or if they are not suited for the vehicle.

## Replacing bulbs

### ⚠ WARNING

Bulbs may become very hot while illuminated. Before replacing bulbs, turn off the lights and wait until the bulbs cool down. Otherwise, there is a risk of sustaining a burn injury.

### ⚠ CAUTION

- Replace any bulb only with a new bulb of the specified wattage. Using a bulb of different wattage could result in a fire. For the specified wattage of each bulb, refer to “Bulb chart” 12-14.
- Do not touch the glass portion of the light bulb with bare hands. When holding the glass portion is unavoidable, hold it using with a clean dry cloth to avoid getting moisture and grease on the bulb. If there is any fingerprints or grease on the bulb surface, wipe them away with a soft cloth moistened with alcohol. Also, if the bulb is scratched or dropped, it may blow out or crack.

### ■ Headlights (models with LED headlights)

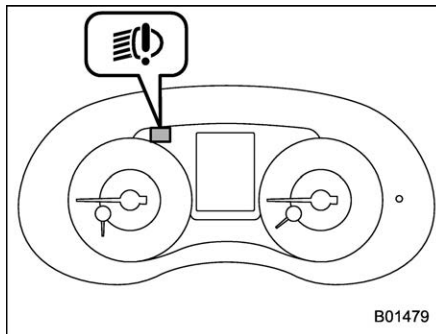

The LED headlight warning light illuminates if the LED headlights malfunction. Have your vehicle inspected at a SUBARU dealer as soon as possible.

### ■ High beam headlight (models without LED headlights)

#### NOTE

- If headlight aiming is required, consult your SUBARU dealer for proper adjustment of the headlight aim.
- It may be difficult to replace the bulbs. Have the bulbs replaced by your SUBARU dealer if necessary.

Perform the following steps to replace the bulbs.

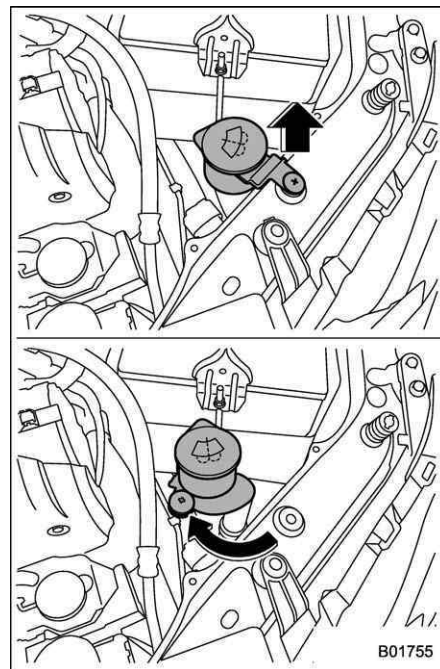

Left-hand side

1. **Left-hand side:** Use a screwdriver to remove the secured clip of the washer tank. To make it easy to access the bulb, turn the neck of the washer fluid filler pipe as illustrated.

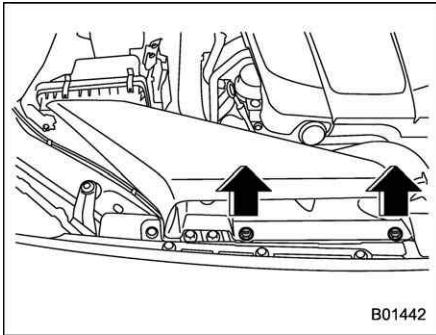

Right-hand side

**Right-hand side:** Use a screwdriver to undo the clips on the air intake duct, then remove the air intake duct.

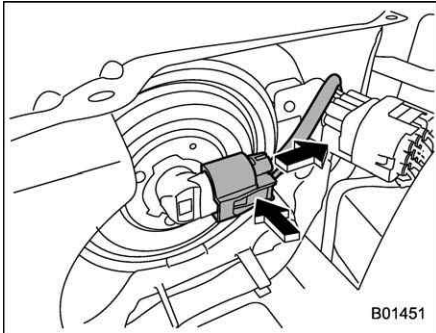

2. Disconnect the electrical connector from the bulb as pushing the tab.

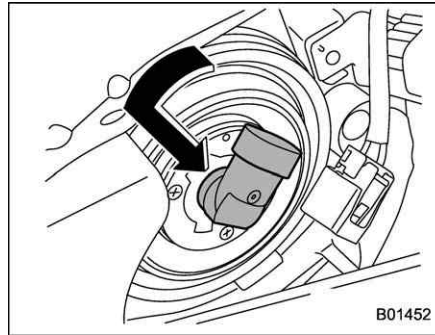

Left-hand side

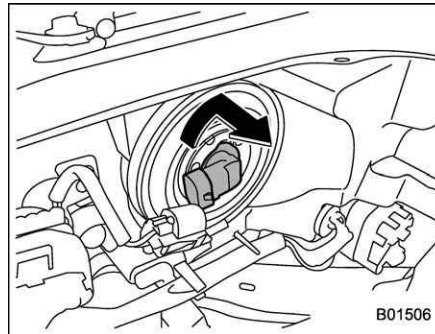

Right-hand side

3. **Left-hand side:** Remove the bulb from the headlight assembly by turning it counterclockwise.

**Right-hand side:** Remove the bulb from

the headlight assembly by turning it clockwise.

4. Replace the bulb with a new one. At this time, use care not to touch the bulb surface.

5. To install the bulb to the headlight assembly, turn it to the reverse direction until it clicks.

6. Reconnect the electrical connector.

7. **Left-hand side:** Set the washer fluid filler pipe to the original place and secure it by a clip.

**Right-hand side:** Install the air intake duct with clips.

■ **Low beam headlight\*, front side marker light, parking light\* and front turn signal light\***

\*: Models without LED headlights

**NOTE**

- If headlight aiming is required, consult your SUBARU dealer for proper adjustment of the headlight aim.
- It may be difficult to replace the bulbs. Have the bulbs replaced by your SUBARU dealer if necessary.

1. Start the engine and turn the steering wheel fully in the opposite direction of the bulb to be replaced.

2. Stop the engine.

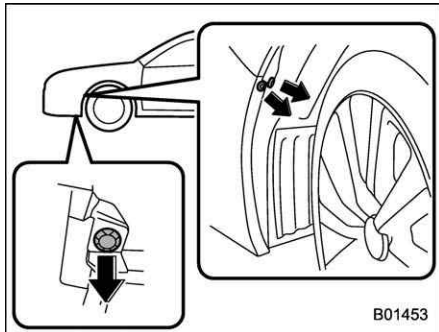

3. Remove the clips from the mud guard.

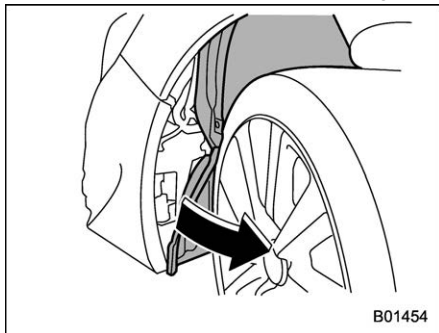

4. Pull off the mud guard.

▼ **Low beam headlight**

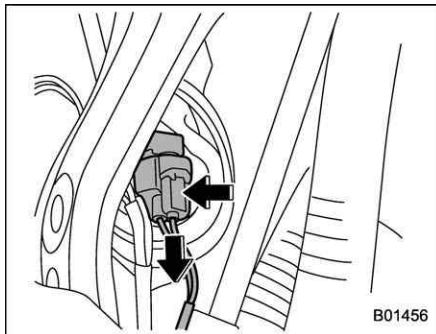
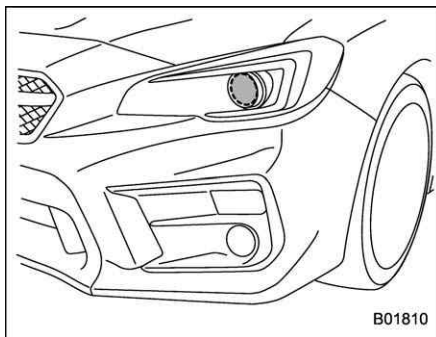

1. Disconnect the electrical connector from the bulb as pushing the tab.

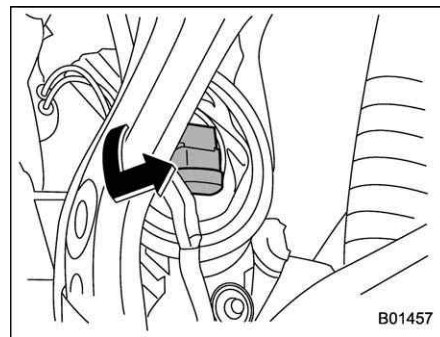

2. Remove the bulb from the headlight assembly by turning it counterclockwise.
3. Replace the bulb with a new one. At this time, use care not to touch the bulb surface.
4. To install the bulb to the headlight assembly, turn it clockwise until it clicks.
5. Reconnect the electrical connector.
6. Reattach the mud guard.

▼ **Front side marker light, parking light and front turn signal light**

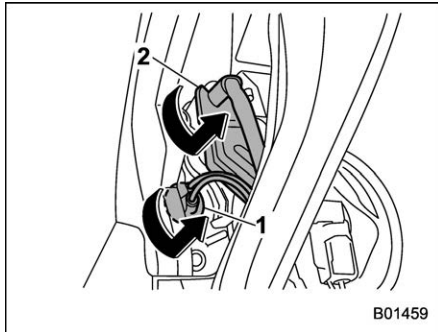
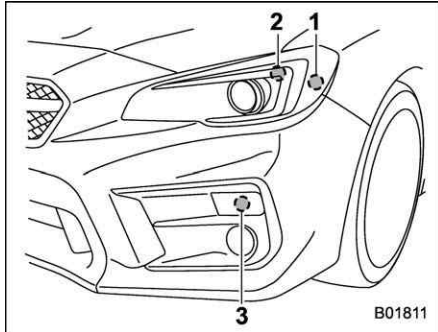

- 1) Front side marker light
- 2) Parking light

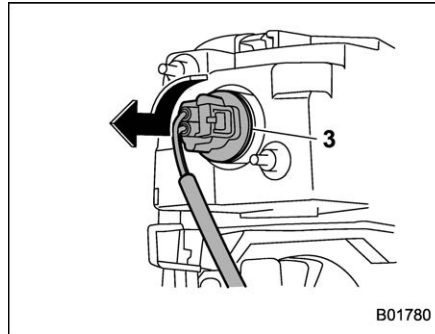

3) Front turn signal light

1. Turn the socket counterclockwise and pull it out.
2. Pull out the bulb from the socket and replace the bulb with a new one.
3. After replacing the bulb, reattach the mud guard.

■ **Front turn signal light (models with LED headlights)**

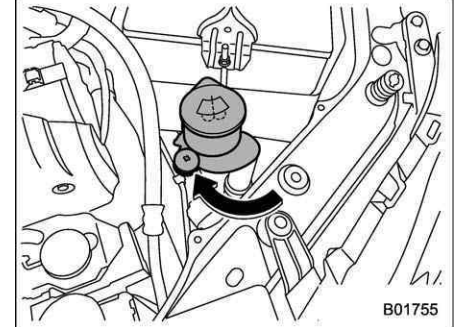
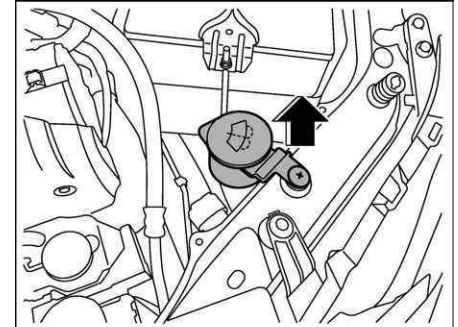

**Left-hand side**

1. **Left-hand side:** Use a screwdriver to remove the secured clip of the washer tank. To make it easy to access the bulb,

turn the neck of the washer fluid filler pipe as illustrated.

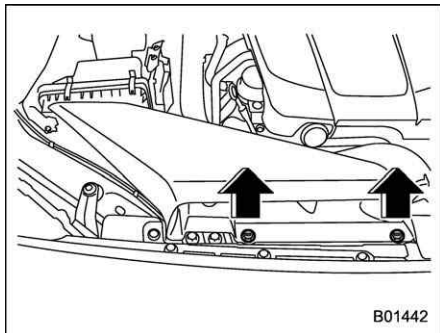

**Right-hand side**

**Right-hand side:** Use a screwdriver to undo the clips on the air intake duct, then remove the air intake duct.

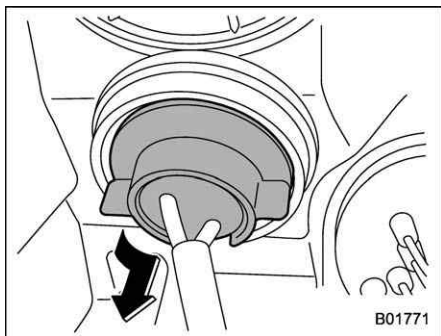

2. Remove the bulb from the headlight assembly by turning it counterclockwise.
  3. Replace the bulb with a new one. At this time, use care not to touch the bulb surface.
  4. To install the bulb to the headlight assembly, turn it clockwise until it clicks.
  5. **Left-hand side:** Set the washer fluid filler pipe to the original place and secure it with a clip.
- Right-hand side:** Install the air intake duct with clips.

■ **Front fog light (models with the LED front fog light)**

Have the front fog light assembly checked by your SUBARU dealer.

■ **Front fog light (models without the LED front fog light) (if equipped)**

**NOTE**

It may be difficult to replace the bulbs. Have the bulbs replaced by your SUBARU dealer if necessary.

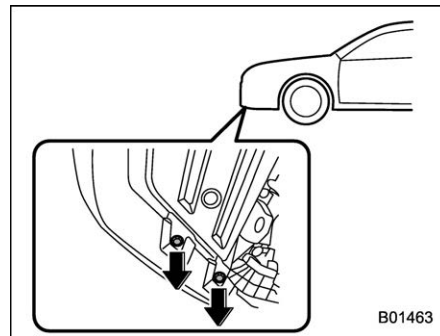

1. Remove the clips.



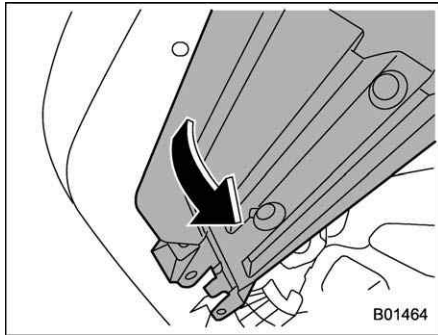

2. Turn over the mud guard.

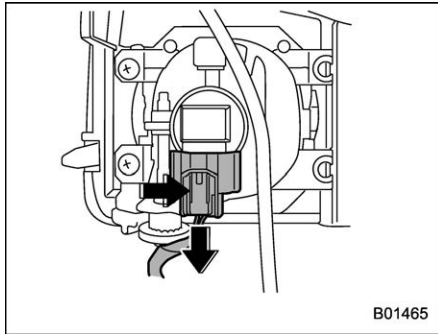

3. Disconnect the electrical connector from the bulb as pushing the tab.

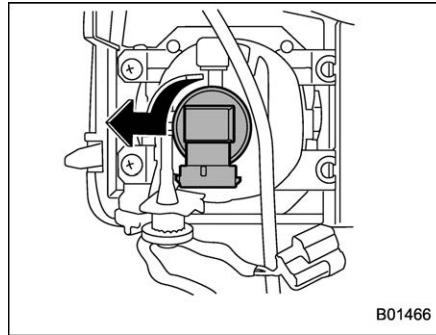

4. Remove the bulb by turning it counter-clockwise.  
5. Replace the bulb with a new one.  
6. Reattach the mud guard.

## ■ Rear combination lights

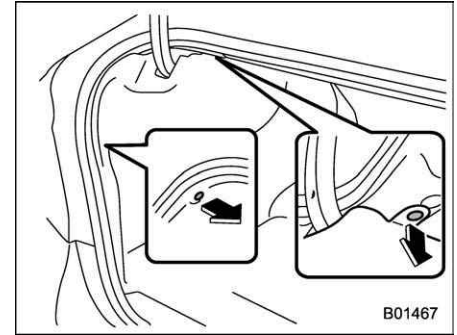

1. Remove the clips from the trunk trim with a flat-head screwdriver.

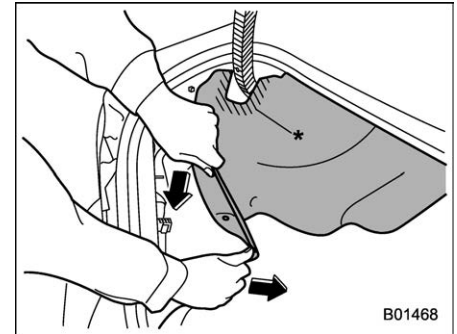

2. Open the rear portion of the trunk trim panel as illustrated.

## NOTE

Make sure that the “\*” part of the trunk trim in the illustration does not contact the trunk lid stay. If the “\*” part is bent, the trunk trim may be torn.

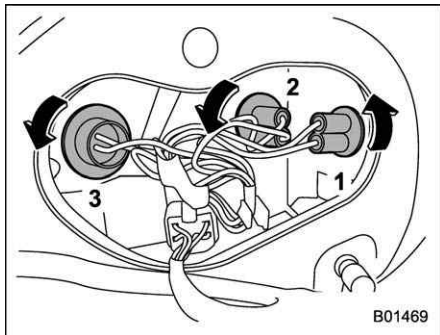

- 1) Rear side marker light
- 2) Backup light
- 3) Rear turn signal light

3. Remove the bulb socket from the rear combination light assembly by turning it counterclockwise.

4. Pull the bulb out of the bulb socket and replace it with a new one.

5. Set the bulb socket into the rear combination light assembly and turn it clockwise until it locks.

6. Secure the rear trunk trim panel with the clips.

## NOTE

When replacing a bulb of the rear side marker light, detach the bulb socket of the backup light in advance. After replacing the bulb, first attach the side marker light, and then attach the back-up light.

### ■ License plate light

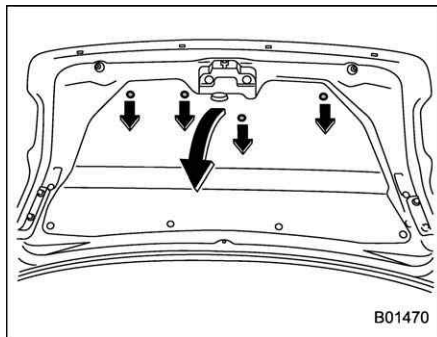

1. Open the trunk and remove the clips from the trunk lid trim with a flat-head screwdriver.

2. Turn over the trunk lid trim.

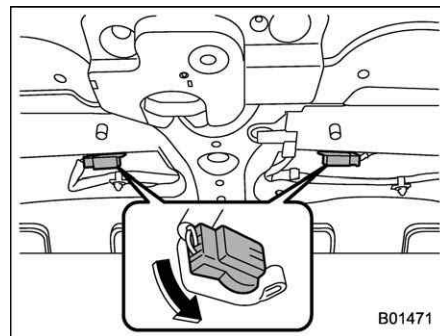

3. Turn the bulb socket counterclockwise and pull out the socket.

4. Pull the bulb out of the socket.

5. Install a new bulb.

6. Reinstall the bulb socket and the trunk lid trim.

## ■ Dome light

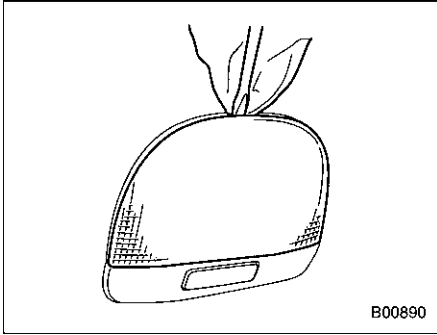

1. Remove the lens by prying the edge of the lens with a flat-head screwdriver.
2. Pull the bulb out of the socket.
3. Install a new bulb.
4. Reinstall the lens.

## ■ Trunk light

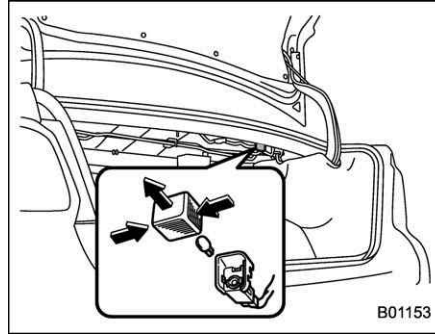

1. Remove the cover by squeezing its sides and pulling it.
2. Pull the bulb out of the socket.
3. Install a new bulb.
4. Reinstall the cover.

## ■ Vanity mirror light

### ⚠ CAUTION

Replacing the bulb could cause burns since the bulb may be very hot. We recommend that you have the bulb replaced by your SUBARU dealer.

## ■ Other bulbs

It may be difficult to replace the bulbs. Have the bulbs replaced by your SUBARU dealer if necessary.

## Replacing battery

The access key fob/transmitter battery may be discharged under the following conditions.

- The operation of the keyless access function is unstable.
- The operating distance of the remote keyless entry system is unstable.
- The transmitter does not operate properly when used within the standard distance.

Replace the battery with a new one.

### ■ Safety precautions

#### CAUTION

- Do not let dust, oil or water get on or in the access key fob/transmitter when replacing battery.
- Before replacing the battery, remove any static electricity.
- Be careful not to touch or damage the printed circuit board in the access key fob/transmitter when replacing the battery.
- Be careful not to allow children to touch the battery and any removed parts; children could

swallow them.

- There is a danger of an explosion if the battery is incorrectly replaced. Replace only with the same or equivalent type of the battery.
- Do not expose batteries to excessive heat such as bright sunlight, fire or the like.

#### NOTE

- Replace only with the same or equivalent type of battery recommended by the manufacturer.
- Dispose of used batteries according to local laws.
- Mount the battery in the correct orientation to prevent fluid leakage. Be careful not to bend the terminals. It may result in a malfunction.
- It is recommended that the battery should be replaced by a SUBARU dealer.
- Use a new battery.
- After replacing the battery, confirm that the access key fob/transmitter functions properly.

### ■ Replacing battery of access key fob

#### CAUTION

When removing or reinstalling the access key fob cover, make sure that the plastic part does not come off or become misaligned.

**Battery:** Button battery CR2032 or equivalent

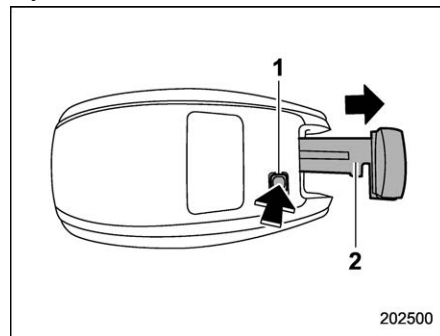

- 1) Release button
- 2) Emergency key

1. Take out the emergency key.

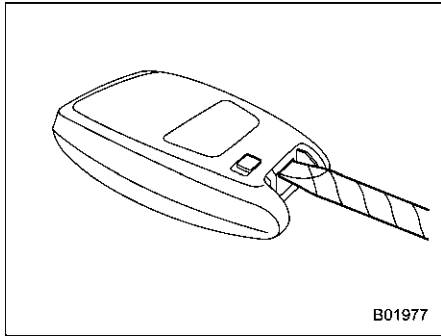

2. Wrap a flat-head screwdriver with vinyl tape or a cloth, and insert it in the gap to remove the cover.

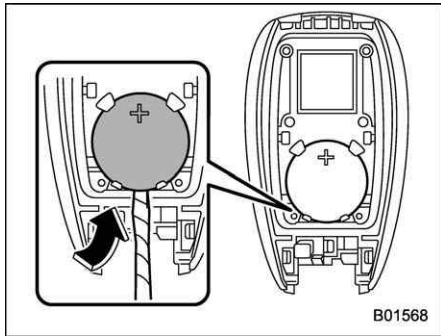

3. Take out the battery using a flat-head screwdriver with vinyl tape or a cloth.

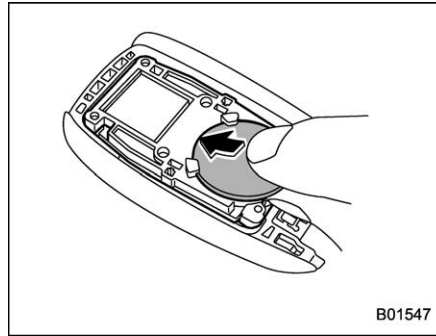

4. Insert a new battery with its positive (+) side facing upward as shown in the figure.

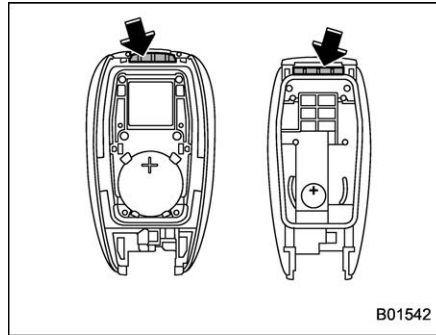

5. Attach the cover to the access key fob by fitting the projections and recesses together.  
6. Reinstall the emergency key.

## ■ Replacing transmitter battery

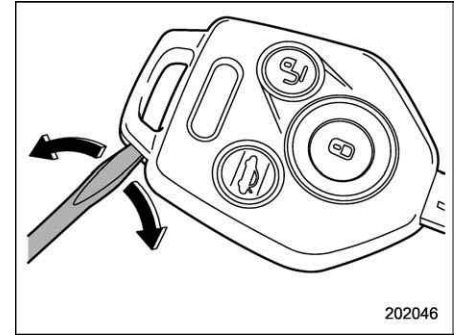

1. Open the key head using a flat-head screwdriver.

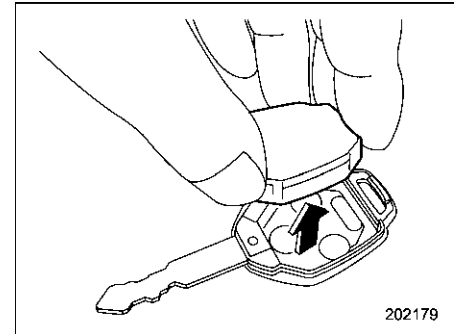

2. Remove the transmitter case from the key head.

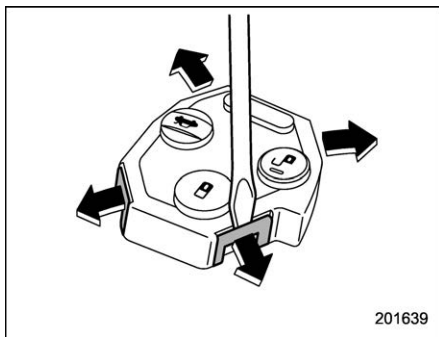

3. Open the transmitter case by releasing the hooks.

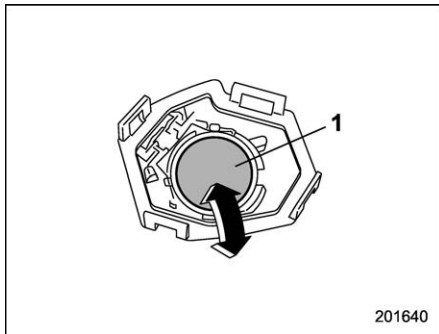

1) Negative (-) side facing up

4. Replace the old battery with a new battery (type **CR1620** or equivalent) making sure to install the new battery with the

negative (-) side facing up.

5. Put together the transmitter case by fitting the hooks on the case.

6. Reinstall the transmitter case in the key head.

7. Refit the removed half of the key head.

**After the battery is replaced, the transmitter must be synchronized with the remote keyless entry system's control unit. Press either the "⏏" or "⏏" button six times to synchronize the unit.**

<b>Specifications</b> .....	<b>12-2</b>	<b>Tires</b> .....	<b>12-8</b>
<b>Dimensions</b> .....	<b>12-2</b>	<b>Temporary spare tires</b> .....	<b>12-9</b>
<b>Engine</b> .....	<b>12-3</b>	<b>Brake disc</b> .....	<b>12-9</b>
<b>Fuel</b> .....	<b>12-3</b>	<b>Fuses and circuits</b> .....	<b>12-10</b>
<b>Engine oil</b> .....	<b>12-4</b>	<b>Fuse panel located in the passenger</b> <b>compartment</b> .....	<b>12-10</b>
<b>Manual transmission, front differential and rear</b> <b>differential gear oil</b> .....	<b>12-6</b>	<b>Fuse panel located in the engine compartment</b> ...	<b>12-12</b>
<b>Fluids</b> .....	<b>12-7</b>	<b>Bulb chart</b> .....	<b>12-14</b>
<b>Engine coolant</b> .....	<b>12-7</b>	<b>Vehicle identification</b> .....	<b>12-16</b>
<b>Electrical system</b> .....	<b>12-8</b>		

## Specifications

---

These specifications are subject to change without notice.

### ■ Dimensions

in (mm)

Overall length		180.9 (4,595)
Overall width		70.7 (1,795)
Overall height		58.1 (1,475)
Wheel base		104.3 (2,650)
Tread	Front	60.2 (1,530)
	Rear	60.6 (1,540)
Ground clearance		4.9 (125)



## ■ Engine

Model	STI	Except STI
Engine model	EJ25 (2.5 L, DOHC, turbo)	FA20 (2.0 L, DOHC, turbo)
Engine type	Horizontally opposed, liquid cooled 4 cylinder, 4-stroke petrol engine	
Displacement cu-in (cc)	150 (2,457)	122 (1,998)
Bore × Stroke in (mm)	3.92 × 3.11 (99.5 × 79.0)	3.39 × 3.39 (86.0 × 86.0)
Compression ratio	8.2 : 1	10.6 : 1
Firing order	1 – 3 – 2 – 4	

## ■ Fuel

### NOTE

The engine is designed to operate using unleaded gasoline.

Model	Fuel	Fuel tank capacity
STI	<b>93 AKI (98 RON) or higher*</b> <sup>1</sup>	15.9 US gal (60 liters, 13.2 Imp gal)
Except STI	<b>91 AKI (95 RON) or higher*</b> <sup>2</sup>	

\*1: If unleaded gasoline with an octane rating of 93 AKI (98 RON) is not available, unleaded gasoline with an octane rating of 91 AKI (95 RON) may be used with no detriment to engine durability or driveability.

\*2: If unleaded gasoline with an octane rating of 91 AKI (95 RON) is not available, unleaded gasoline with an octane rating of 87 AKI (90 RON) or higher may be used.

### ■ Engine oil

For the checking, adding and replacing procedure or other details, refer to “Engine oil” ☞ 11-13.

### NOTE

**Have the procedure for changing the engine oil and oil filter performed by a properly-trained expert. It is recommended that you have this service performed by your SUBARU dealer.**

### ▼ Approved engine oil



Always use the SUBARU approved engine oil. For further details, please contact your SUBARU dealer.  
If the approved engine oil is unavailable, use the alternative engine oil described on the next page.

▼ **Alternative engine oil**



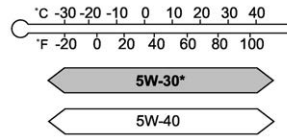

If the SUBARU approved oil is unavailable, the following alternative oil can be used.

**NOTE**

- Each quantity indicated here is only a guideline. The necessary quantity for replacement may differ slightly depending on the temperature and other factors.
- In choosing an oil, you want the proper quality and viscosity, as well as one that will enhance fuel economy. Oils of lower viscosity provide better fuel economy. However, in hot weather, oil of higher viscosity is required to properly lubricate the engine. The following table lists the recommended viscosities and applicable temperatures.
- When adding oil, you may use different brands together as long as they are the same API classification and SAE viscosity as those recommended by SUBARU.

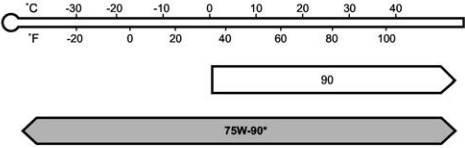
Oil grade	SAE viscosity No. and applicable temperature	Engine oil capacity
<div style="display: flex; justify-content: space-around; align-items: center;"> <div style="text-align: center;">  <p>ZOM0754</p> </div> <p>or</p> <div style="text-align: center;">  <p>ZOM0293</p> </div> </div> <p>API (American Petroleum Institute) classification <b>SN</b> with the words "RESOURCE CONSERVING" or <b>SN PLUS</b> with the words "RESOURCE CONSERVING"</p> <p>ILSAC (International Lubricant Specification Advisory Committee) <b>GF-5</b>, which can be identified with the ILSAC certification mark (Starburst mark)</p>	<p><b>5W-30 synthetic</b> oil is the required oil for optimum engine performance and protection. Conventional oil may be used if synthetic oil is unavailable.</p> <p>*: If 5W-30 synthetic oil is not available, 5W-40 conventional oil may be used if replenishment is needed but should be changed to 5W-30 synthetic oil at the next oil change.</p> <div style="text-align: center;">  <p>ZOM0334</p> </div>	<p><b>STI:</b></p> <ul style="list-style-type: none"> <li>• Adding the oil from L to F level: 1.1 US qt (1.0 liter, 0.9 Imp qt)</li> <li>• Changing the oil and oil filter: 4.5 US qt (4.3 liters, 3.8 Imp qt)</li> <li>• Changing the oil: 4.2 US qt (4.0 liters, 3.5 Imp qt)</li> </ul> <p><b>Except STI:</b></p> <ul style="list-style-type: none"> <li>• Adding the oil from L to F level: 1.1 US qt (1.0 liter, 0.9 Imp qt)</li> <li>• Changing the oil and oil filter: 5.4 US qt (5.1 liters, 4.5 Imp qt)</li> <li>• Changing the oil: 5.2 US qt (4.9 liters, 4.3 Imp qt)</li> </ul>

## Manual transmission, front differential and rear differential gear oil

Oil		Manual transmission oil	Front differential gear oil (CVT models)	Rear differential gear oil
Oil grade	STI	<ul style="list-style-type: none"> <li>API classification GL-5 (75W-90)*<sup>3</sup></li> </ul>	—	API classification GL-5
	Except STI	<ul style="list-style-type: none"> <li>SUBARU Extra MT*<sup>3</sup></li> <li>API classification GL-5 (75W-90)*<sup>4</sup></li> </ul>	<ul style="list-style-type: none"> <li>SUBARU Extra MT*<sup>3</sup></li> <li>API classification GL-5 (75W-90)</li> </ul>	
SAE viscosity No. and applicable temperature		—	—	<ul style="list-style-type: none"> <li>75W-90*</li> <li>90</li> </ul>  <p style="text-align: right;">ZOM0450</p>
				*: Recommended
Oil capacity* <sup>1</sup>	STI	4.3 US qt (4.1 liters, 3.6 Imp qt)	—	1.1 US qt (1.0 liter, 0.9 Imp qt)
	Except STI	3.5 US qt (3.3 liters, 2.9 Imp qt)	1.5 US qt (1.4 liters, 1.2 Imp qt)	0.8 US qt (0.8 liters, 0.7 Imp qt)
Remarks* <sup>2</sup>		"Manual transmission oil"  11-21	"Front differential gear oil (CVT models) and rear differential gear oil"  11-22	"Front differential gear oil (CVT models) and rear differential gear oil"  11-22

\*1: The indicated oil quantity is only a guideline. The necessary quantity for replacement may differ slightly depending on the temperature and other factors. Check the oil level after refilling the gearbox with oil.

\*2: For more details about maintenance and service, refer to the indicated section.

\*3: The vehicle is filled at the factory with this oil.

\*4: You may use this type of manual transmission oil. However, using this type of oil will detract from driveability and fuel efficiency.

## ■ Fluids

Fluid	Fluid type*1	Fluid capacity*2	Remarks*3
Continuously variable transmission fluid (CVT models)	Consult your SUBARU dealer.	13.1 US qt (12.4 liters, 10.9 Imp qt)	"Continuously variable transmission fluid" ☞ 11-22
Brake fluid	FMVSS No. 116, DOT 3 or DOT 4 brake fluid	—	"Brake fluid" ☞ 11-23
Clutch fluid (MT models)	FMVSS No. 116, DOT 3 or DOT 4 brake fluid	—	"Clutch fluid (MT models)" ☞ 11-24
Power steering fluid (STI)	<ul style="list-style-type: none"> <li>· SUBARU ATF</li> <li>· "Dexron III" Type Automatic Transmission Fluid</li> <li>· IDEMITSU ATF HP</li> </ul>	0.7 US qt (0.7 liter, 0.6 Imp qt)	"Power steering fluid (STI)" ☞ 11-22

\*1: Use one of the indicated types of fluid.

\*2: The indicated fluid quantity is only a guideline. The necessary quantity for replacement may differ slightly depending on the temperature and other factors.

\*3: For more details about maintenance and service, refer to the indicated section.

## ■ Engine coolant

Vehicle model		Coolant capacity	Coolant type
STI		8.2 US qt (7.7 liters, 6.8 Imp qt)	SUBARU SUPER COOLANT
Except STI	MT models	8.6 US qt (8.1 liters, 7.2 Imp qt)	
	CVT models	8.8 US qt (8.3 liters, 7.3 Imp qt)	

The indicated coolant quantity is only a guideline. The necessary quantity for replacement may differ slightly depending on the temperature and other factors. For more details about maintenance and service, refer to "Cooling system" ☞ 11-16.

### ■ Electrical system

Battery type		75D23L
Alternator	STI	12 V-110 A
	Except STI	12 V-130 A
Spark plugs	STI	ILFR7H (NGK)
	Except STI	ILKAR8H6 (NGK)

### ■ Tires

Tire size	STI	—	245/40R18 97W*1	245/35R19 89W
	Except STI	235/45R17 94W*1	245/40R18 97W	—
Wheel size		17 × 8J	18 × 8 1/2J	19 × 8 1/2J
Pressure	Front	33 psi (230 kPa, 2.3 kgf/cm <sup>2</sup> )		
	Rear	32 psi (220 kPa, 2.2 kgf/cm <sup>2</sup> )		
Wheel nut tightening torque		89 lbf-ft (120 N·m, 12 kgf·m)*2		

\*1: Except for Mexico

\*2: This torque is equivalent to applying approximately 88 to 110 lbf (40 to 50 kgf) at the end of the wheel nut wrench. If you have tightened the wheel nuts by yourself, have the tightening torque checked at the nearest automotive service facility as soon as possible. For the wheel nut tightening procedure, refer to "Changing a flat tire" 9-4.

## ■ Temporary spare tires

	For U.S. and Canada		For Mexico	
Temporary spare tire size	T145/70D17	T135/70D18	205/50R17	205/45R18
Temporary spare tire inflation pressure (recommended cold tire inflation pressure)	60 psi (420 kPa, 4.2 kgf/cm <sup>2</sup> )		33 psi (230 kPa, 2.3 kgf/cm <sup>2</sup> )	38 psi (260 kPa, 2.6 kgf/cm <sup>2</sup> )
Wheel nut tightening torque	89 lbf·ft (120 N·m, 12 kgf·m)*1*2			

\*1: This torque is equivalent to applying approximately 88 to 110 lbf (40 to 50 kgf) at the end of the wheel nut wrench. If you have tightened the wheel nuts by yourself, have the tightening torque checked at the nearest automotive service facility as soon as possible.

\*2: For the wheel nut tightening procedure, refer to "Changing a flat tire" 9-4.

## ■ Brake disc

If you need information on the usage limit value of brake discs and the method for measuring them, consult your SUBARU dealer.

## Fuses and circuits

### ■ Fuse panel located in the passenger compartment

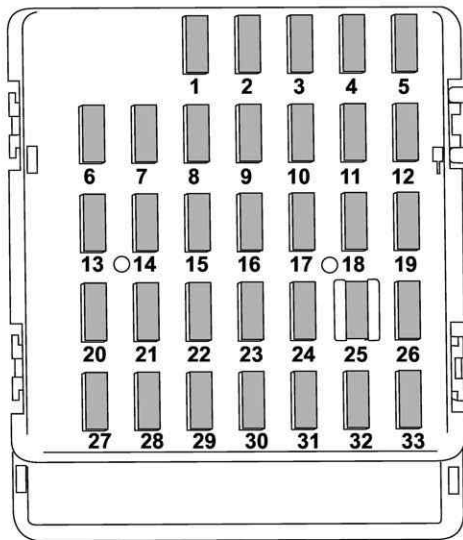

C00123

Fuse panel	Fuse rating	Circuit
1	20 A	R.FOG TRAIL
2	7.5 A	METER IG
3	15 A	DOOR LOCK
4	10 A	IG2
5	Empty	
6	7.5 A	MIR
7	15 A	UNIT+B
8	7.5 A	STOP
9	7.5 A	WIPER DEICE
10	7.5 A	D-OP+B
11	7.5 A	TURN IG
12	15 A	UNIT IG1
13	20 A	12 V PLUG
14	10 A	TAIL CLEARANCE
15	10 A	BKUP+B
16	7.5 A	ILM
17	15 A	SEAT HTR
18	10 A	LAMP IG
19	Empty	
20	10 A	CIGAR
21	10 A	START
22	7.5 A	A/C IG



<b>Fuse panel</b>	<b>Fuse rating</b>	<b>Circuit</b>
23	Empty	
24	10 A	AUDIO NAVI
25	15 A	SRS AIR BAG
26	7.5 A	IG1
27	15 A	BLOWER
28	15 A	BLOWER
29	15 A	F.FOG
30	Empty	
31	7.5 A	ACC
32	7.5 A	STR LOCK
33	7.5 A	UNIT IG2

### ■ Fuse panel located in the engine compartment

▼ STI

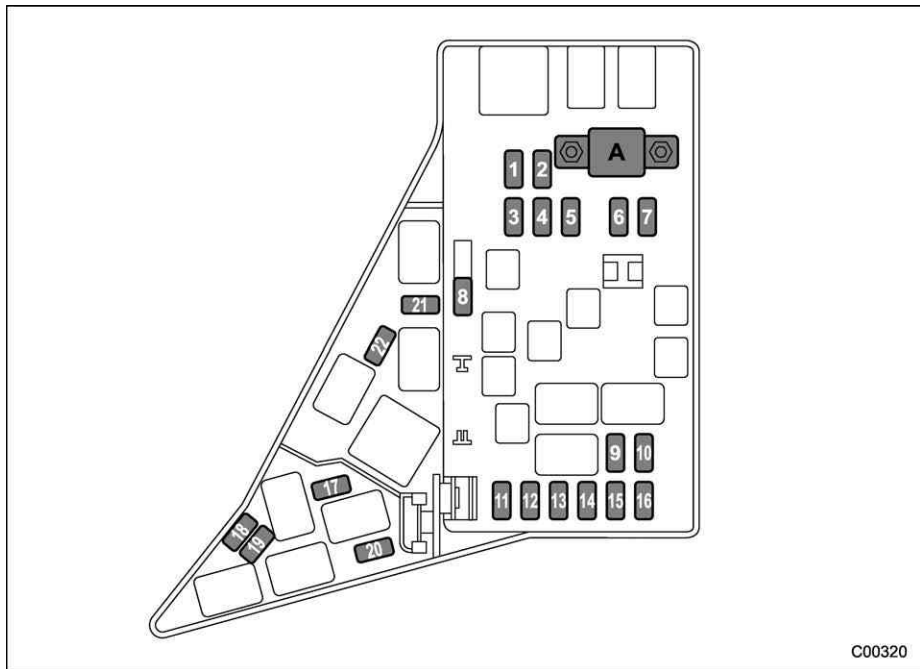

C00320

A) Main fuse

Fuse panel	Fuse rating	Circuit
1	30 A	ABS SOL
2	25 A	MAIN FAN
3	25 A	SUB FAN
4	Empty	
5	25 A	AUDIO AMP
6	30 A	H/L LO
7	15 A	H/L HI
8	20 A	BACK UP
9	15 A	HORN
10	25 A	R.DEF
11	15 A	FUEL PUMP
12	10 A	(Transmission control unit)
13	7.5 A	EGI+B
14	15 A	HAZARD
15	15 A	LIGHTING
16	7.5 A	ALT-S
17	Empty	
18	20 A	INJ
19	15 A	H/L LO RH
20	15 A	H/L LO LH
21	10 A	AIR CUT
22	7.5 A	(Telematics)

▼ Except STI

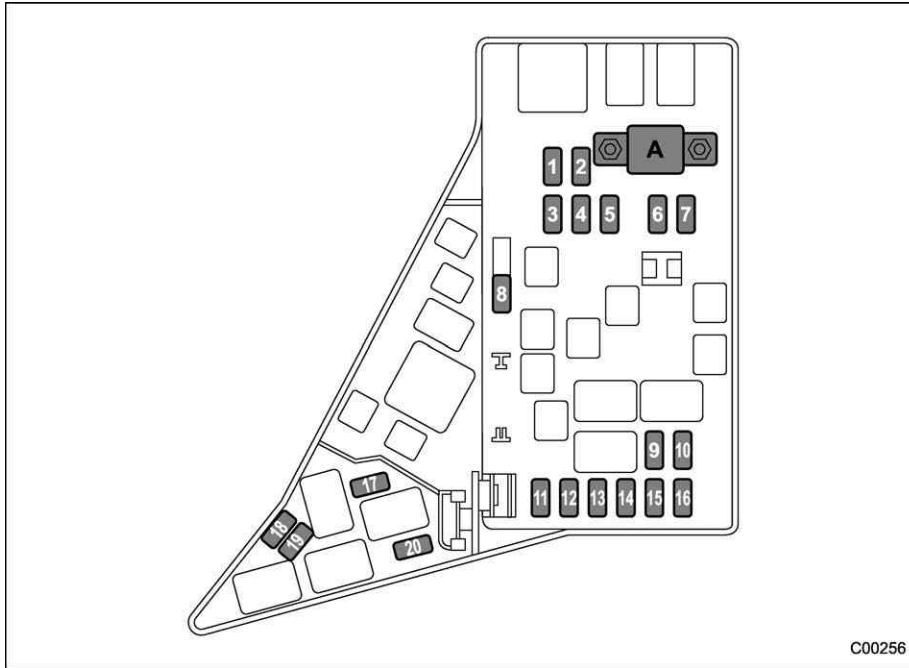

Fuse panel	Fuse rating	Circuit
1	30 A	ABS SOL
2	25 A	MAIN FAN
3	25 A	SUB FAN
4	Empty	
5	25 A	AUDIO AMP
6	30 A	H/L LO
7	15 A	H/L HI
8	20 A	BACK UP
9	15 A	HORN
10	25 A	R.DEF
11	15 A	FUEL PUMP
12	20 A	(Transmission control unit)
13	7.5 A	EGI+B
14	15 A	HAZARD
15	15 A	LIGHTING
16	7.5 A	ALT-S
17	Empty	
18	20 A	INJ
19	15 A	H/L LO RH
20	15 A	H/L LO LH

A) Main fuse

C00256

## Bulb chart

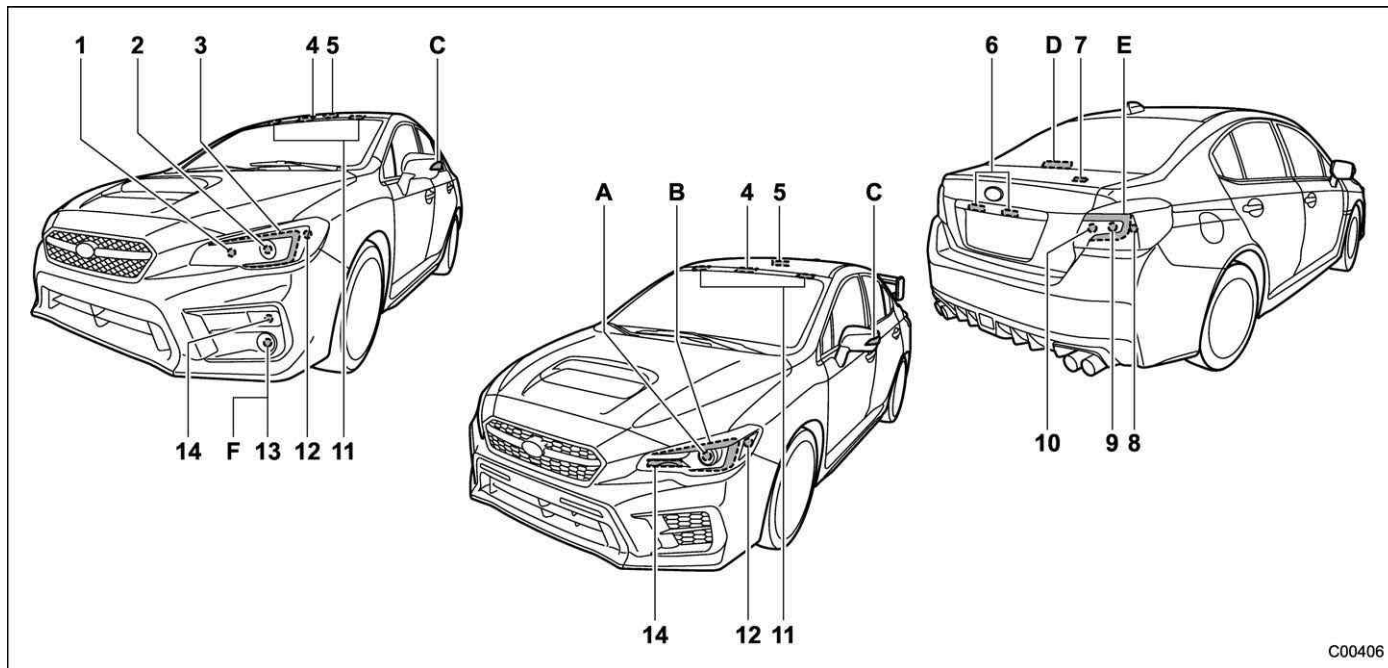

### NOTE

Lights indicated by letters are the LED (Light Emitting Diode) type. Consult your SUBARU dealer for replacement.

	Wattage	Bulb No.
1) High beam headlight (models without LED headlights)	12 V-60 W	HB3
2) Low beam headlight (models without LED headlights)	12 V-55 W	H11
3) Parking light (models without LED headlights)	12 V-5 W	W5W
4) Map light	12 V-8 W	—
5) Dome light	12 V-8 W	—
6) License plate light	12 V-5 W	W5W
7) Trunk light	12 V-5 W	W5W
8) Rear side marker light	12 V-5 W	W5W
9) Backup light	12 V-16 W	W16W
10) Rear turn signal light	12 V-21 W	WY21W
11) Vanity mirror light	12 V-2 W	—
12) Front side marker light	12 V-5 W	W5W
13) Front fog light (models without LED fog lights)	12 V-19 W	H16
14) Front turn signal light	12 V-21 W	WY21W
A) Low and high beam headlight (models with LED headlights)	—	—
B) Parking light (models with LED headlights)	—	—
C) Side turn signal light (if equipped)	—	—
D) High-mounted stop light	—	—
E) Stop light/Tail light	—	—
F) Front fog light (models with LED fog lights)	—	—

**WARNING**

**Bulbs may become very hot while illuminated. Before replacing bulbs, turn off the lights and wait until the bulbs cool down. Otherwise, there is a risk of sustaining a burn injury.**

**CAUTION**

**Replace any bulb only with a new bulb of the specified wattage. Using a bulb of different wattage could result in a fire.**

## Vehicle identification

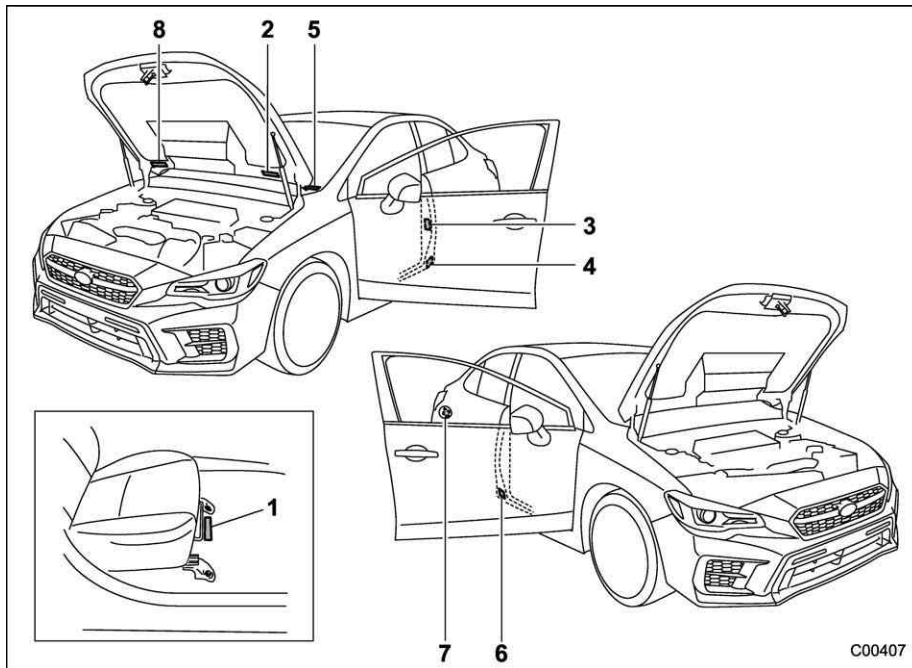

- 1) Vehicle identification number (under the floor carpet of the right-hand front seat)
- 2) Emission control label
- 3) Tire inflation pressure label
- 4) Certification label
- 5) Vehicle identification number
- 6) Model number label
- 7) Fuel label
- 8) Air conditioner label

# ***Consumer information and Reporting safety defects***

---

<b>For U.S.A. ....</b>	<b>13-2</b>	<b>Uniform tire quality grading standards.....</b>	<b>13-15</b>
<b>Tire information.....</b>	<b>13-2</b>	<b>TREADWEAR.....</b>	<b>13-15</b>
<b>Tire labeling.....</b>	<b>13-2</b>	<b>TRACTION AA, A, B, C.....</b>	<b>13-15</b>
<b>Recommended tire inflation pressure .....</b>	<b>13-4</b>	<b>TEMPERATURE A, B, C.....</b>	<b>13-15</b>
<b>Glossary of tire terminology.....</b>	<b>13-5</b>	<b>Reporting safety defects (U.S.A.).....</b>	<b>13-16</b>
<b>Tire care – maintenance and safety practices .....</b>	<b>13-10</b>	<b>How to contact Transport Canada in order to</b>	
<b>Vehicle load limit – how to determine.....</b>	<b>13-10</b>	<b>report a safety concern relating to the</b>	
<b>Determining compatibility of tire and vehicle</b>		<b>vehicle (Canada).....</b>	<b>13-17</b>
<b>load capacities.....</b>	<b>13-13</b>		
<b>Adverse safety consequences of overloading</b>			
<b>on handling and stopping and on tires.....</b>	<b>13-14</b>		
<b>Steps for Determining Correct Load Limit.....</b>	<b>13-14</b>		

## For U.S.A.

The following information has been compiled according to Code of Federal Regulations "Title 49, Part 575".

## Tire information

### ■ Tire labeling

Many markings (e.g. Tire size, Tire Identification Number or TIN) are placed on the sidewall of a tire by tire manufacturers. These markings can provide you with useful information on the tire.

### ▼ Tire size

Your vehicle comes equipped with P-Metric tire size. It is important to understand the sizing system in selecting the proper tire for your vehicles. Here is a brief review of the tire sizing system with a breakdown of its individual elements.

#### ▽ P Metric

With the P-Metric system, Section Width is measured in millimeters. To convert millimeters into inches, divide by 25.4. The Aspect Ratio (Section Height divided by Section Width) helps provide more dimensional information about the tire size.

## Example:

**P 205 / 55 R 16**  
(1) (2) (3) (4) (5)

- (1) P = Certain tire type used on light duty vehicles such as passenger cars
- (2) Section Width in millimeters
- (3) Aspect Ratio (= section height ÷ section width).
- (4) R = Radial Construction
- (5) Rim diameter in inches

### ▽ Load and Speed Rating Descriptions

The load and speed rating descriptions will appear following the size designation.

They provide two important facts about the tire. First, the number designation is its load index. Second, the letter designation indicates the tire's speed rating.



**Example:**

**P 205 / 55 R 16 89 V**  
 Size designation (6) (7)

(6) Load Index: A numerical code which specifies the maximum load a tire can carry at the speed indicated by its speed symbol, at maximum inflation pressure.

For example, “90” means 1,323 lbs (600 kg), “89” means 1,278 lbs (580 kg).



**WARNING**

**Load indices apply only to the tire, not to the vehicle. Putting a load rated tire on any vehicle does not mean the vehicle can be loaded up to the tire’s rated load.**

(7) Speed Rating: An alphabetical system describing a tire’s capability to travel at established and predetermined speeds.

For example, “V” means 149 mph (240 km/h)



**WARNING**

- **Speed ratings apply only to the tire, not to the vehicle. Putting a speed rated tire on any vehicle does not mean the vehicle can be operated at the tire’s rated speed.**
- **The speed rating is void if the tires are worn out, damaged, repaired, retreaded, or otherwise altered from their original condition. If tires are repaired, re-treaded, or otherwise altered, they may not be suitable for original equipment tire designed loads and speeds.**

**▼ Tire Identification Number (TIN)**

Tire Identification Number (TIN) is marked on the intended outboard sidewall. The TIN is composed of four groups. Here is a brief review of the TIN with a breakdown of its

individual elements.

**DOT XX XX XXX XXXX**  
 (1) (2) (3) (4) (5)

- (1) DOT symbol\*
- (2) Manufacturer’s Identification Mark
- (3) Tire Size Code
- (4) Tire Type Code
- (5) Date of Manufacture

The first two figures identify the week, starting with “01” to represent the first full week of the calendar year; the second two figures represent the year. For example, 0101 means the 1st week of 2001.

\*: The DOT symbol certifies that the tire conforms to applicable Federal Motor Vehicle Safety Standards.

▼ **Other markings**

The following makings are also placed on the sidewall.

▽ **Maximum permissible inflation pressure**

The maximum cold inflation pressure to which this tire may be inflated. For example, “300 kPa (44 PSI) MAX. PRESS”

▽ **Maximum load rating**

The load rating at the maximum permissible weight load for this tire. For example, “MAX. LOAD 580 kg (1279 LBS) @ 300 kPa (44 PSI) MAX. PRESS.”

**⚠ WARNING**

**Maximum load rating applies only to the tire, not to the vehicle. Putting a load rated tire on any vehicle does not mean the vehicle can be loaded up to the tire’s rated load.**

▽ **Construction type**

Applicable construction of this tire. For example, “TUBELESS STEEL BELTED RADIAL”

▽ **Construction**

The generic name of each cord material used in the plies (both sidewall and tread area) of this tire. For example, “PLIES: TREAD 2 STEEL + 2 POLYESTER SIDEWALL 2 POLYESTER”

▽ **Uniform Tire Quality Grading (UTQG)**

For details, refer to “Uniform tire quality grading standards” 13-15.

■ **Recommended tire inflation pressure**

▼ **Recommended cold tire inflation pressure**

For recommended cold tire inflation pressure for your vehicle’s tires, refer to “Tires” 12-8.

▼ **Vehicle placard**

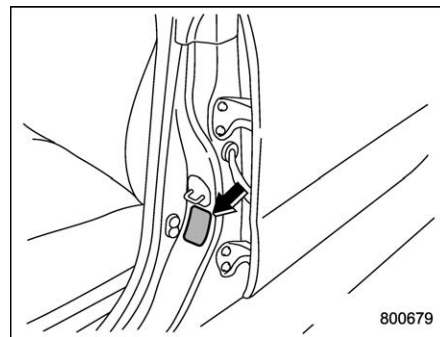

The vehicle placard is affixed to the driver’s side B-pillar.

**Example:**

TIRE AND LOADING INFORMATION RENSEIGNEMENTS SUR LES PNEUS ET LE CHARGEMENT			
	SEATING CAPACITY / TOTAL X	FRONT	REAR
	NUMBER OF PLACES / PNEUS A FROID	AVANT	ARRIERE
The combined weight of occupants and cargo should never exceed XXXkg or XXXlbs. Le poids total des occupants et du chargement ne doit jamais dépasser XXXkg ou XXXlb.			
TIRE PNEU	SIZE DIMENSIONS	COLD TIRE PRESSURE / PRESSION DES PNEUS A FROID	SEE OWNER'S MANUAL FOR ADDITIONAL INFORMATION VOIR LE MANUEL DE L'USAGER POUR PLUS DE RENSEIGNEMENTS
FRONT AVANT	PXXXXXXRXX	XXXKPA, XXPSI	
REAR ARRIERE	PXXXXXXRXX	XXXKPA, XXPSI	
SPARE DE SECOURS	TXXXXDXX	XXXKPA, XXPSI	

XX

The vehicle placard shows original tire size, recommended cold tire inflation pressure on each tire at maximum loaded vehicle weight, seating capacity and loading information.

#### ▼ **Adverse safety consequences of under-inflation**

Driving at high speeds with excessively low tire pressures can cause the tires to flex severely and to rapidly become hot. A sharp increase in temperature could cause tread separation, and failure of the tire(s). Possible resulting loss of vehicle control could lead to an accident.

#### ▼ **Measuring and adjusting air pressure to achieve proper inflation**

Check and, if necessary, adjust the pressure of each tire (including the spare) at least once a month and before any long journey. Check the tire pressures when the tires are cold. Use a pressure gauge to

adjust the tire pressures to the specific values. Driving even a short distance warms up the tires and increases the tire pressures. Also, the tire pressures are affected by the outside temperature. It is best to check tire pressure outdoors before driving the vehicle. When a tire becomes warm, the air inside it expands, causing the tire pressure to increase. Be careful not to mistakenly release air from a warm tire to reduce its pressure.

#### ■ **Glossary of tire terminology**

##### ● **Accessory weight**

The combined weight (in excess of those standard items which may be replaced) of automatic transmission, power steering, power brakes, power windows, power seats, radio, and heater, to the extent that these items are available as factory-installed equipment (whether installed or not).

##### ● **Bead**

The part of the tire that is made of

steel wires, wrapped or reinforced by ply cords and that is shaped to fit the rim.

##### ● **Bead separation**

A breakdown of the bond between components in the bead.

##### ● **Bias ply tire**

A pneumatic tire in which the ply cords that extend to the beads are laid at alternate angles substantially less than 90 degrees to the centerline of the tread.

##### ● **Carcass**

The tire structure, except tread and sidewall rubber which, when inflated, bears the load.

##### ● **Chunking**

The breaking away of pieces of the tread or sidewall.

##### ● **Cold tire pressure**

The pressure in a tire that has been driven less than 1 mile or has been standing for three hours or more.

##### ● **Cord**

The strands forming the plies in the tire.

- **Cord separation**

The parting of cords from adjacent rubber compounds.

- **Cracking**

Any parting within the tread, sidewall, or inner liner of the tire extending to cord material.

- **Curb weight**

The weight of a motor vehicle with standard equipment including the maximum capacity of fuel, oil and coolant, and if so equipped, air conditioning and additional weight optional engine.

- **Extra load tire**

A tire designed to operate at higher loads and higher inflation pressure than the corresponding standard tire.

- **Groove**

The space between two adjacent tread ribs.

- **Innerliner**

The layer(s) forming the inside surface of a tubeless tire that contains the inflating medium within the tire.

- **Innerliner separation**

The parting of the innerliner from cord material in the carcass.

- **Intended outboard sidewall**

(1) The sidewall that contains a whitewall, bears white lettering or bears manufacturer, brand, and/or model name molding that is higher or deeper than the same molding on the other sidewall of the tire, or

(2) The outward facing sidewall of an asymmetrical tire that has a particular side that must always face outward when mounting on a vehicle.

- **Light truck (LT) tire**

A tire designated by its manufacturer as primarily intended for use on lightweight trucks or multipurpose passenger vehicles.

- **Load rating**

The maximum load that a tire is rated to carry for a given inflation pressure.

- **Maximum inflation pressure**

The maximum cold inflation pres-

sure to which a tire may be inflated.

- **Maximum load rating**

The load rating for a tire at the maximum permissible inflation pressure for that tire.

- **Maximum loaded vehicle weight**

The sum of:

- (a) Curb weight
- (b) Accessory weight
- (c) Vehicle capacity weight
- (d) Production options weight

- **Maximum permissible inflation pressure**

The maximum cold inflation pressure to which a tire may be inflated.

- **Measuring rim**

The rim on which a tire is fitted for physical dimension requirements.

- **Normal occupant weight**

150 lbs (68 kg) times the number of occupants specified in the second column of Table 1 that is appended to the end of this section.

- **Occupant distribution**

Distribution of occupants in a vehicle as specified in the third column of Table 1 that is appended to the

end of this section.

- **Open splice**

Any parting at any junction of tread, sidewall, or innerliner that extends to cord material.

- **Outer diameter**

The overall diameter of an inflated new tire.

- **Overall width**

The linear distance between the exteriors of the sidewalls of an inflated tire, including elevations due to labeling, decorations, or protective bands or ribs.

- **Passenger car tire**

A tire intended for use on passenger cars, multipurpose passenger vehicles, and trucks, that have a gross vehicle weight rating (GVWR) of 10,000 lbs (4,535 kg) or less.

- **Ply**

A layer of rubber-coated parallel cords.

- **Ply separation**

A parting of rubber compound between adjacent plies.

- **Pneumatic tire**

A mechanical device made of rubber, chemicals, fabric and steel or other materials, that, when mounted on an automotive wheel, provides the traction and contains the gas or fluid that sustains the load.

- **Production options weight**

The combined weight of those installed regular production options weighing over 5.1 lbs (2.3 kg) in excess of those standard items which they replace, not previously considered in curb weight or accessory weight, including heavy duty brakes, ride levelers, roof rack, heavy duty battery, and special trim.

- **Radial ply tire**

A pneumatic tire in which the ply cords that extend to the beads are laid at substantially 90 degrees to the centerline of the tread.

- **Recommended inflation pressure**

The cold inflation pressure recommended by a vehicle manufacturer.

- **Reinforced tire**

A tire designed to operate at higher loads and at higher inflation pressures than the corresponding standard tire.

- **Rim**

A metal support for a tire or a tire and tube assembly upon which the tire beads are seated.

- **Rim diameter**

Nominal diameter of the bead seat.

- **Rim size designation**

Rim diameter and width.

- **Rim type designation**

The industry of manufacturer's designation for a rim by style or code.

- **Rim width**

Nominal distance between rim flanges.

- **Section width**

The linear distance between the exteriors of the sidewalls of an inflated tire, excluding elevations due to labeling, decoration, or protective bands.

- **Sidewall**

That portion of a tire between the

tread and bead.

- **Sidewall separation**

The parting of the rubber compound from the cord material in the sidewall.

- **Snow tire**

A tire that attains a traction index equal to or greater than 110, compared to the ASTM E1136-93 Standard Reference Test Tire, when using the snow traction test as described in ASTM F-1805-00, Standard Test Method for Single Wheel Driving Traction in a Straight Line on Snow-and Ice-Covered Surfaces, and that is marked with an Alpine Symbol “” on at least one sidewall.

- **Test rim**

The rim on which a tire is fitted for testing, and it may be any rim listed as appropriate for use with that tire.

- **Tread**

That portion of a tire that comes into contact with the road.

- **Tread rib**

A tread section running circumfer-

entially around a tire.

- **Tread separation**

Pulling away of the tread from the tire carcass.

- **Treadwear indicators (TWI)**

The projections within the principal grooves designed to give a visual indication of the degrees of wear of the tread.

- **Vehicle capacity weight**

The rated cargo and luggage load plus 150 lbs (68 kg) times the vehicle’s designated seating capacity.

- **Vehicle maximum load on the tire**

Load on an individual tire that is determined by distributing to each axle its share of the maximum loaded vehicle weight and dividing by two.

- **Vehicle normal load on the tire**

Load on an individual tire that is determined by distributing to each axle its share of the curb weight, accessory weight, and normal occupant weight (distributed in accordance with Table 1 that is appended

to the end of this section) and dividing by 2.

- **Wheel-holding fixture**

The fixture used to hold the wheel and tire assembly securely during testing.

Table 1 — Occupant loading and distribution for vehicle normal load for various designated seating capacities

Designated seating capacity, number of occupants	Vehicle normal load, number of occupants	Occupant distribution in a normally loaded vehicle
2 through 4	2	2 in front.
5 through 10	3	2 in front, 1 in second seat.
11 through 15	5	2 in front, 1 in second seat, 1 in third seat, 1 in fourth seat.
16 through 22	7	2 in front, 2 in second seat, 2 in third seat, 1 in fourth seat.

### ■ Tire care – maintenance and safety practices

- Check on a daily basis that the tires are free from serious damage, nails, and stones. At the same time, check the tires for abnormal wear.
- Inspect the tire tread regularly and replace the tires before their tread wear indicators become visible. When a tire's tread wear indicator becomes visible, the tire is worn beyond the acceptable limit and must be replaced immediately. With a tire in this condition, driving at even low speeds in wet weather can cause the vehicle to hydroplane. Possible resulting loss of vehicle control can lead to an accident.
- To maximize the life of each tire and ensure that the tires wear uniformly, it is best to rotate the tires every 6,000 miles (10,000 km). For information about the tire rotation order, refer to "Tire rotation" ☞ 11-35. Replace any damaged or unevenly worn tires at the time of rotation. After tire rotation, adjust the

tire pressures and make sure the wheel nuts are correctly tightened. For information about the tightening torque and tightening sequence for the wheel nuts, refer to "Flat tires" ☞ 9-4.

### ■ Vehicle load limit – how to determine

The load capacity of your vehicle is determined by weight, not by available cargo space. The load limit of your vehicle is shown on the vehicle placard attached to the driver's side B-pillar. Locate the statement "The combined weight of occupants and cargo should never exceed XXX kg or XXX lbs" on your vehicle's placard.

The vehicle placard also shows seating capacity of your vehicle.

The total load capacity includes the total weight of driver and all passengers and their belongings, any cargo, any optional equipment such as a roof rack or bike carrier, etc. Therefore cargo capacity can be calculated by the following method.

Cargo capacity = Load limit – (total weight of occupants + total weight of optional equipment)

For information about vehicle loading, refer to "Loading your vehicle" ☞ 8-10.



**CAUTION**

**Your vehicle is neither designed nor intended to be used for trailer towing. Therefore, never tow a trailer with your vehicle.**



▼ **Calculating total and load capacities varying seating configurations**

Calculate the available load capacity as shown in the following examples:

**Example 1A**

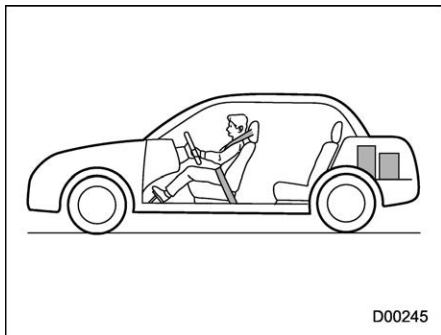

Vehicle capacity weight of the vehicle is 900 lbs (408 kg), which is indicated on the vehicle placard with the statement “The combined weight of occupants and cargo should never exceed 900 lbs or 408 kg”.

For example, if the vehicle has one

occupant weighing 154 lbs (70 kg) plus cargo weighing 662 lbs (300 kg).

1. Calculate the total weight.

**Total weight**

$$= \frac{154 \text{ lbs (70 kg)}}{\text{(Occupant)}} + \frac{662 \text{ lbs (300 kg)}}{\text{(Cargo)}}$$

$$= \mathbf{816 \text{ lbs (370 kg)}}$$

2. Calculate the available load capacity by subtracting the total weight from the vehicle capacity weight of 900 lbs (408 kg).

**Available Load Capacity**

$$= \frac{900 \text{ lbs (408 kg)}}{\text{(Vehicle capacity weight)}} - \frac{816 \text{ lbs (370 kg)}}{\text{(Total weight)}}$$

$$= \mathbf{84 \text{ lbs (38 kg)}}$$

3. The result of step 2 shows that a further 84 lbs (38 kg) of cargo can be carried.

**Example 1B**

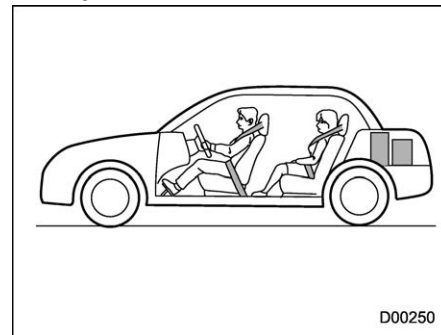

For example, if a person weighing 176 lbs (80 kg) now enters the same vehicle (bringing the number of occupants to two), the calculations are as follows.

1. Calculate the total weight.

**Total weight**

$$= \frac{154 \text{ lbs (70 kg)}}{\text{(Occupant)}} + \frac{176 \text{ lbs (80 kg)}}{\text{(Occupant)}}$$

$$+ \frac{662 \text{ lbs (300 kg)}}{\text{(Cargo)}}$$

$$= \mathbf{992 \text{ lbs (450 kg)}}$$

2. Calculate the available load capacity.

**Available Load Capacity**

$$= \frac{900 \text{ lbs (408 kg)}}{\text{(Vehicle capacity weight)}} - \frac{992 \text{ lbs (450 kg)}}{\text{(Total weight)}}$$

$$= -92 \text{ lbs (-42 kg)}$$

3. The total weight now exceeds the capacity weight by 92 lbs (42 kg), so the cargo weight must be reduced by 92 lbs (42 kg) or more.

**Example 2A**



**Your vehicle is neither designed nor intended to be used for trailer towing. Therefore, never tow a trailer with your vehicle.**

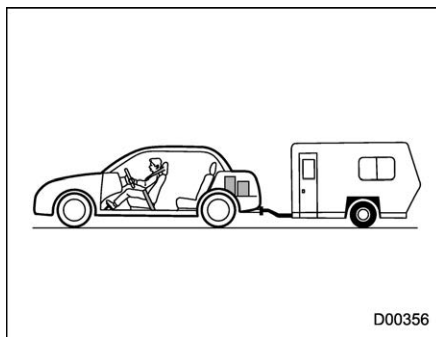

Vehicle capacity weight of the vehicle is 800 lbs (363 kg), which is indicated on the vehicle placard with the statement “The combined weight of occupants and cargo should never exceed 363 kg or 800 lbs”.

For example, the vehicle has one occupant weighing 165 lbs (75 kg) plus cargo weighing 265 lbs (120 kg). In addition, the vehicle is fitted with a trailer hitch weighing 22 lbs (10 kg), to which is attached a trailer weighing 1,764 lbs (800 kg). 10% of the trailer weight is applied to the trailer tongue (i.e. Tongue load =

176 lbs (80 kg)).

1. Calculate the total weight.

**Total weight**

$$= \frac{165 \text{ lbs (75 kg)}}{\text{(Occupant)}} + \frac{265 \text{ lbs (120 kg)}}{\text{(Cargo)}}$$

$$+ \frac{22 \text{ lbs (10 kg)}}{\text{(Trailer hitch)}} + \frac{176 \text{ lbs (80 kg)}}{\text{(Tongue load)}}$$

$$= 628 \text{ lbs (285 kg)}$$

2. Calculate the available load capacity.

**Available Load Capacity**

$$= \frac{800 \text{ lbs (363 kg)}}{\text{(Vehicle capacity weight)}} - \frac{628 \text{ lbs (285 kg)}}{\text{(Total weight)}}$$

$$= 172 \text{ lbs (78 kg)}$$

3. The result of step 2 shows that a further 172 lbs (78 kg) of cargo can be carried.

**Example 2B**

**CAUTION**

**Your vehicle is neither designed nor intended to be used for trailer towing. Therefore, never tow a trailer with your vehicle.**

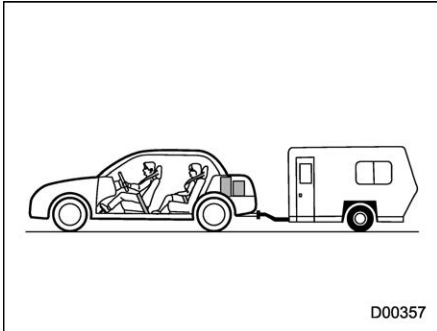

For example, if a person weighing 143 lbs (65 kg) and a child weighing 40 lbs (18 kg) now enter the same vehicle (bringing the number of occupants to three), and a child restraint system weighing 11 lbs (5 kg) is installed in the vehicle for the

child to use, the calculations are as follows:

1. Calculate the total weight.

**Total weight**

$$= \frac{165 \text{ lbs (75 kg)} + 143 \text{ lbs (65 kg)}}{\text{(Occupant)}}$$

$$+ \frac{40 \text{ lbs (18 kg)}}{\text{(Occupant)}}$$

$$+ \frac{11 \text{ lbs (5 kg)}}{\text{(Child restraint)}} + \frac{265 \text{ lbs (120 kg)}}{\text{(Cargo)}}$$

$$+ \frac{22 \text{ lbs (10 kg)}}{\text{(Trailer hitch)}} + \frac{176 \text{ lbs (80 kg)}}{\text{(Tongue load)}}$$

$$= \mathbf{822 \text{ lbs (373 kg)}}$$

2. Calculate the available load capacity.

**Available Load Capacity**

$$= \frac{800 \text{ lbs (363 kg)}}{\text{(Vehicle capacity weight)}} - \frac{822 \text{ lbs (373 kg)}}{\text{(Total weight)}}$$

$$= \mathbf{-22 \text{ lbs (-10 kg)}}$$

3. The total weight now exceeds the capacity weight by 22 lbs (10 kg), so the cargo weight must be

reduced by 22 lbs (10 kg) or more.

**■ Determining compatibility of tire and vehicle load capacities**

The sum of four tires' maximum load ratings must exceed the maximum loaded vehicle weight ("GVWR"). In addition, sum of the maximum load ratings of two front tires and of two rear tires must exceed each axle's maximum loaded capacity ("GAWR"). Original equipment tires are designed to fulfill those conditions.

The maximum loaded vehicle weight is referred to Gross Vehicle Weight Rating (GVWR). And each axle's maximum loaded capacity is referred to Gross Axle Weight Rating (GAWR). The GVWR and each axle's GAWR are shown on the vehicle certification label affixed to the driver's door.

The GVWR and front and rear GAWRs are determined by not only the maximum load rating of tires but

also loaded capacities of the vehicle's suspension, axles and other parts of the body.

Therefore, this means that the vehicle cannot necessarily be loaded up to the tire's maximum load rating on the tire sidewall.

**■ Adverse safety consequences of overloading on handling and stopping and on tires**

Overloading could affect vehicle handling, stopping distance, and vehicle and tire performance in the following ways. This could lead to an accident and possibly result in severe personal injury.

- Vehicle stability will deteriorate.
- Heavy and/or high-mounted loads could increase the risk of rollover.
- Stopping distance will increase.
- Brakes could overheat and fail.
- Suspension, bearings, axles and other body parts could break or experience accelerated wear that

will shorten vehicle life.

- Tires could fail.
- Tread separation could occur.
- Tire could separate from its rim.

**■ Steps for Determining Correct Load Limit**

1. Locate the statement "The combined weight of occupants and cargo should never exceed XXX kg or XXX lbs." on your vehicle's placard.
2. Determine the combined weight of the driver and passengers that will be riding in your vehicle.
3. Subtract the combined weight of the driver and passengers from XXX kg or XXX lbs.
4. The resulting figure equals the available amount of cargo and luggage load capacity. For example, if the "XXX" amount equals 1400 lbs. and there will be five 150 lb passengers in your vehicle, the amount of available cargo and luggage load capacity is 650 lbs. (1400 - 750 (5 × 150) = 650 lbs.)

5. Determine the combined weight of luggage and cargo being loaded on the vehicle. That weight may not safely exceed the available cargo and luggage load capacity calculated in Step 4.

6. If your vehicle will be towing a trailer, load from your trailer will be transferred to your vehicle. Consult this manual to determine how this reduces the available cargo and luggage load capacity of your vehicle.

## Uniform tire quality grading standards

This information indicates the relative performance of passenger car tires in the area of treadwear, traction, and temperature resistance. This is to aid the consumer in making an informed choice in the purchase of tires.

Quality grades can be found where applicable on the tire sidewall between tread shoulder and maximum section width. For example:

### **TREADWEAR 200 TRACTION AA TEMPERATURE A**

The quality grades apply to new pneumatic tires for use on passenger cars. However, they do not apply to deep tread, winter type snow tires, space-saver or temporary use spare tires, tires with nominal rim diameters of 12 inches or less, or to some limited production tires.

All passenger car tires must con-

form to Federal Safety Requirements in addition to these grades.

### ■ TREADWEAR

The treadwear grade is a comparative rating based on the wear rate of the tire when tested under controlled conditions on a specified government test course.

For example, a tire graded 150 would wear one and one-half (1-1/2) times as well on the government course as a tire graded 100. The relative performance of tires depends upon the actual conditions of their use, however, and may depart significantly from the norm due to variations in driving habits, service practices and differences in road characteristics and climate.

### ■ TRACTION AA, A, B, C

The traction grades, from highest to lowest, are AA, A, B and C. Those grades represent the tire's ability to stop on wet pavement as measured under controlled conditions on spe-

cified government test surfaces of asphalt and concrete. A tire marked C may have poor traction performance.



### **WARNING**

**The traction grade assigned to this tire is based on straight-ahead braking traction tests, and does not include acceleration, cornering, hydroplaning, or peak traction characteristics.**

### ■ TEMPERATURE A, B, C

The temperature grades are A (the highest), B, and C, representing the tire's resistance to the generation of heat and its ability to dissipate heat when tested under controlled conditions on a specified indoor laboratory test wheel. Sustained high temperature can cause the material of the tire to degenerate and reduce tire life, and excessive temperature can lead to sudden tire failure. The

grade C corresponds to a level of performance which all passenger car tires must meet under the Federal Motor Vehicle Safety Standard No. 109. Grades B and A represent higher levels of performance on the laboratory test wheel than the minimum required by law.



**WARNING**

**The temperature grade for this tire is established for a tire that is properly inflated and not overloaded. Excessive speed, underinflation, or excessive loading, either separately or in combination, can cause heat buildup and possible tire failure.**

## **Reporting safety defects (U.S.A.)**

If you believe that your vehicle has a defect which could cause a crash or could cause injury or death, you should immediately inform the National Highway Traffic Safety Administration (NHTSA) in addition to notifying Subaru of America, Inc.

If NHTSA receives similar complaints, it may open an investigation, and if it finds that a safety defect exists in a group of vehicles, it may order a recall and remedy campaign. However, NHTSA cannot become involved in individual problems between you, your dealer, or Subaru of America, Inc. To contact NHTSA, you may call the Vehicle Safety Hotline toll-free at 1-888-327-4236 (TTY: 1-800-424-9153); go to <http://www.safercar.gov>; or write to: Administrator, NHTSA, 1200 New Jersey Avenue, SE, West Building, Washington, DC 20590. You can also obtain other

information about motor vehicle safety from <http://www.safercar.gov>.

## How to contact Transport Canada in order to report a safety concern relating to the vehicle (Canada)

---

Transport Canada - ASFAD  
330 Sparks Street  
Ottawa, ON K1A 0N5

Telephone: 819-994-3328  
(Ottawa-Gatineau area or internationally)  
Toll free: 1-800-333-0510 (in Canada)

Online:  
<http://www.tc.gc.ca/recalls>

Transports Canada - ASFAD  
330, rue Sparks  
Ottawa (Ontario) K1A 0N5

Téléphone: 819-994-3328  
(dans la région de Ottawa-Gatineau et à l'extérieur du pays)  
Sans frais: 1-800-333-0510 (au Canada)

Internet:  
<http://www.tc.gc.ca/rappels>

D01001

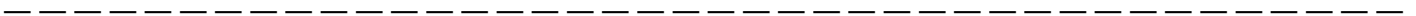
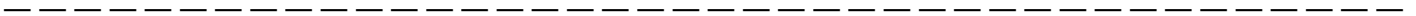
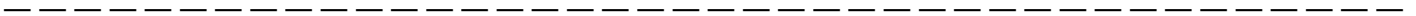
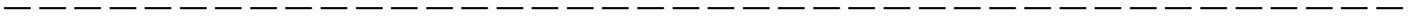
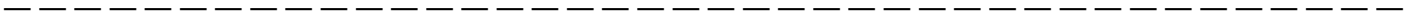
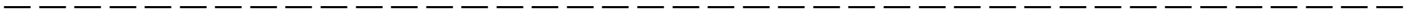
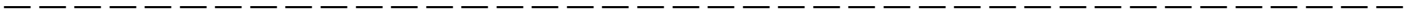
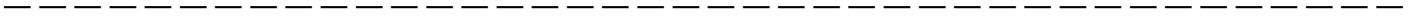
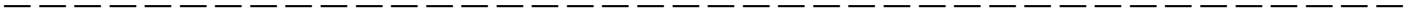





<b>A</b>	
Abbreviation.....	3
ABS (Anti-lock Brake System).....	7-34
Warning light.....	3-20
Access key	
Warning indicator.....	3-29
Access key fob.....	2-7
Warning light.....	3-28, 3-29
Accessories.....	11-43
Accessory power outlet.....	6-8
Air cleaner element.....	11-18
Air conditioner	
Automatic climate control.....	4-5
Manual climate control.....	4-6
Airflow mode.....	4-6
All-Wheel Drive warning light.....	3-25
Alloy wheel.....	11-37
Cleaning.....	10-3
Antenna	
Roof antenna (for Shark fin type).....	5-2
Anti-lock Brake System (ABS).....	7-34
Armrest.....	1-11
Ashtray.....	6-11
Assist grip.....	6-12
AT OIL TEMP warning light.....	3-18
Audio	
Antenna system.....	5-2
Auto dimmer cancel function.....	3-73
Auto Vehicle Hold function	
ON indicator light.....	3-24
Operation indicator light.....	3-24
Auto-dimming mirror/compass.....	3-77, 3-78
Automatic headlight beam leveler.....	3-73
Warning light.....	3-35
Automatic Locking Retractor/Emergency Locking Retractor (ALR/ELR).....	1-13
Automatic transmission	
Oil temperature warning light (AT OIL TEMP).....	3-18
<b>B</b>	
Battery.....	11-41
Drainage prevention function.....	2-5
Jump starting.....	9-9
Replacement (access key fob).....	11-52
Replacement (keyless access with push-button start system).....	2-16, 11-52
Replacement (remote keyless entry system)....	2-21, 11-53
Replacement (transmitter).....	11-53
Booster seat.....	1-30
Bottle holder.....	6-7
Brake	
Assist.....	7-33
Booster.....	7-33, 11-25
Disc.....	12-9
Fluid.....	11-23, 12-7
Pad.....	11-28
Parking.....	7-42, 11-29
Pedal.....	11-26
System.....	7-33
Brake pedal	
Free play.....	11-26
Reserve distance.....	11-26

- |  |            |  |             |
|--|------------|--|-------------|
| Brake system .....                               | 7-33       | Coolant level.....                         | 11-17       |
| Warning light.....                               | 3-21       | Fluid level (brake fluid).....             | 11-23       |
| Braking.....                                     | 7-32       | Fluid level (clutch fluid).....            | 11-24       |
| Tips.....  | 7-32       | Fluid level (power steering fluid).....    | 11-22       |
| Breaking-in of new brake pads .....              | 11-28      | Fluid level (washer fluid).....            | 11-38       |
| BSD/RCTA.....                                    | 7-56       | Oil level (engine oil).....                | 11-13       |
| Approach indicator light/warning buzzer.....     | 7-60       | Child restraint systems.....               | 1-21        |
| OFF indicator.....                               | 7-62       | Installation of a booster seat.....        | 1-30        |
| OFF switch.....                                  | 7-63       | Installation with ALR/ELR seatbelt.....    | 1-25        |
| Warning indicator.....                           | 7-62       | Lower and top tether anchorages.....       | 1-31        |
| Warning light.....                               | 3-37, 7-62 | Top tether anchorages.....                 | 1-34        |
| Bulb   |            | Child safety .....                         | 5           |
| Chart.....                                       | 12-14      | Locks.....                                 | 2-31        |
| Replacing.....                                   | 11-44      | Chime                                      |             |
| <b>C</b>   |            | Light.....                                 | 3-65        |
| Catalytic converter .....                        | 8-3        | Seatbelt .....                             | 3-14        |
| Center   |            | Cigarette lighter .....                    | 6-9         |
| Console.....                                     | 6-5        | Cleaning                                   |             |
| Changing   |            | Alloy wheels .....                         | 10-3        |
| Coolant.....                                     | 11-18      | Interior .....                             | 10-5        |
| Flat tire.....                                   | 9-4        | Ventilation grille.....                    | 4-10        |
| Oil and oil filter .....                         | 11-15      | Climate control system.....                | 4-3         |
| Charge warning light .....                       | 3-17       | Automatic.....                             | 4-5         |
| CHECK ENGINE warning light/Malfunction indicator |            | Manual.....                                | 4-6         |
| light.....                                       | 3-16       | Clock .....                                | 3-44, 3-64  |
| Checking   |            | Clutch                                     |             |
| Brake pedal free play .....                      | 11-26      | Fluid.....                                 | 11-24, 12-7 |
| Brake pedal reserve distance .....               | 11-26      | Pedal.....                                 | 11-27       |
| Clutch function .....                            | 11-27      | Coat hook .....                            | 6-13        |
| Clutch pedal free play .....                     | 11-27      | Combination meter display (color LCD)..... | 3-37        |
|  |            | Compass.....                               | 3-77, 3-78  |

Console .....	6-5
Continuously variable transmission (CVT).....	7-23
Fluid .....	11-22
Coolant.....	11-17, 12-7
Cooling system.....	11-16
Corrosion protection.....	10-4
Cruise control.....	7-53
Indicator light.....	3-35
Set indicator light.....	3-35
Cup holder.....	6-6
Front passenger's.....	6-6
Rear passenger's .....	6-7

**D**

Daytime running light system .....	3-70
Defogger .....	3-86
Defrosting .....	4-9
Deicer .....	3-86
Differential gear oil	
Front.....	11-22, 12-6
Rear.....	11-22, 12-6
Dimensions .....	12-2
Disc brake pad wear warning indicators .....	7-33
Dome light .....	6-2, 11-51
Door	
Locks .....	2-4
Open warning light.....	3-25
Double trip meter.....	3-9
Drive belts .....	11-20
Driver's Control Center Differential.....	7-19
Auto indicator light .....	3-36

Indicator light .....	3-36
Driving	
All-Wheel Drive warning light.....	3-25
AWD vehicles .....	8-5
Car phone/cell phone.....	7
Drinking .....	6
Drugs.....	6
Foreign countries .....	8-4
Pets.....	8
Snowy and icy roads .....	8-8
Tips .....	7-18, 7-28, 8-2, 8-5
Tired or sleepy.....	7
Winter.....	8-6

**E**

ECO gauge .....	3-12
Electrical system .....	12-8
Electronic Brake Force Distribution (EBD) system.....	3-22, 7-35
Electronic parking brake.....	7-42
Automatic release function by accelerator pedal .....	7-44
Light .....	3-22
Warning .....	3-22, 7-45
Emergency Locking Retractor (ELR).....	1-13
Engine	
Compartment overview .....	11-11
Coolant.....	11-17, 12-7
Exhaust gas (carbon monoxide).....	6, 8-2
Hood .....	11-9
Low oil level warning light .....	3-17
Oil .....	11-13, 12-4

Overheating .....	9-12
Starting & stopping .....	7-9
Event data recorder .....	9
Exterior care .....	10-2

**F**

Flat tires .....	9-4
Floor mat .....	6-11
Fluid level	
Brake .....	11-23
Clutch .....	11-24
Continuously variable transmission .....	11-22
Power steering .....	11-22
Fog light .....	3-73
Bulb .....	11-48
Indicator light .....	3-35
Switch .....	3-73
Front	
Differential gear oil .....	11-22, 12-6
Fog light .....	3-73, 11-48
Fog light indicator light .....	3-35
Seatbelt pretensioners .....	1-17
View Monitor .....	6-14
Front fog light .....	3-73, 11-48
Switch .....	3-73
Front seats .....	1-2
Forward and backward adjustment .....	1-4
Head restraint adjustment .....	1-5
Manual seat .....	1-4
Power seat .....	1-5
Reclining .....	1-4

Seat height adjustment (driver's seat) .....	1-4
Fuel .....	7-3
Consumption indicator .....	3-47, 3-48
Economy hints .....	8-2
Filler door and cap .....	7-5
Filler lid and cap .....	7-5
Gauge .....	3-10
Requirements .....	7-3, 12-3
Fuses .....	11-42
Fuses and circuits .....	12-10

**G**

GAWR (Gross Axle Weight Rating) .....	8-12
Glove box .....	6-5
GVWR (Gross Vehicle Weight Rating) .....	8-12

**H**

Hazard warning flasher .....	3-8, 9-2
Head restraint adjustment	
Front seat .....	1-5
Rear seat .....	1-8
Headlight	
Beam leveler .....	3-73
Bulb replacement .....	11-44
Bulb replacing .....	11-44
Bulb wattage .....	12-14
Control switch .....	3-65
Flasher .....	3-70
Indicator light .....	3-35
OFF delay function .....	3-66
OFF delay setting .....	3-66

Welcome lighting function .....	3-66
High Beam Assist	
Indicator light.....	3-35
High beam assist function.....	3-67
High beam indicator light .....	3-35
High/low beam change (dimmer) .....	3-67
Hill start assist.....	7-49, 11-27
OFF indicator light .....	3-24
To activate/deactivate .....	7-51
Warning light .....	3-24
HomeLink®.....	3-78
Hook	
Coat.....	6-13
Towing and tie-down .....	9-13
Horn.....	3-88
Hose and connections .....	11-16
<b>I</b>	
Ignition switch .....	3-4
Illumination brightness control .....	3-72
Immobilizer	
Indicator light (security indicator light).....	3-33
Indicator light	
Auto Vehicle Hold ON .....	3-24
Auto Vehicle Hold operation .....	3-24
BSD/RCTA OFF .....	3-37
BSD/RCTA warning.....	3-37
Cruise control.....	3-35
Cruise control set.....	3-35
Driver's Control Center Differential.....	3-36
Driver's Control Center Differential Auto .....	3-36

Front fog light .....	3-35
Headlight.....	3-35
High beam.....	3-35
High Beam Assist.....	3-35
Hill start assist OFF .....	3-24
Malfunction.....	3-16
RAB OFF .....	3-37
REV .....	3-37
Security.....	3-33
Select lever/Gear position .....	3-34
Shift-up .....	3-34
SI-DRIVE .....	3-34
Steering Responsive Headlight OFF .....	3-37
Traction mode.....	3-27
Turn signal .....	3-35
Vehicle Dynamics Control OFF .....	3-27
Vehicle Dynamics Control operation .....	3-26, 3-27
Inside mirror .....	3-77
Interior lights.....	6-2
Internal trunk lid release handle .....	2-37

**J**

Jack-up point .....	9-4
Jump starting.....	9-9

**K**

Key.....	2-2
Number.....	2-3
Keyless access with push-button start system .....	2-7
Disabling keyless access functions.....	2-14
Locking and unlocking doors .....	2-11

Opening trunk .....	2-11
Warning chimes and warning indicator .....	2-14, 3-28
When access key does not operate properly .....	2-16
When access key fob does not operate properly .....	9-18
<b>L</b>	
Leather seat materials .....	10-5
LED headlights .....	11-44
License plate light .....	11-50
Light	
Control switch .....	3-65
Daytime running .....	3-70
Dome .....	6-2, 11-51
Front fog .....	3-73, 11-48
Front position .....	3-65, 3-73
License plate .....	11-50
Map .....	6-2
Rear combination .....	11-49
Rear side marker light .....	11-49
Stop light .....	11-51
Tail light .....	11-51
Trunk .....	11-51
Turn signal .....	3-72, 11-49
Vanity mirror .....	11-51
Limited slip differential (LSD) .....	7-31
Loading your vehicle .....	8-10
Low fuel warning light .....	3-24
Low tire pressure warning light .....	3-18
Lower and top tether anchorage .....	1-31
LSD (Limited slip differential) .....	7-31

**M**

Maintenance	
Precautions .....	11-3
Schedule .....	11-3
Seatbelt .....	1-17
Tips .....	11-6
Tools .....	9-3
Malfunction indicator light (check engine warning light) ...	3-16
Manual	
Climate control .....	4-6
Mode (continuously variable transmission) .....	7-25
Seat .....	1-4
Transmission .....	7-16
Transmission oil .....	11-21, 12-6
Map light .....	6-2
Meters and gauges .....	3-8
Mirror defogger .....	3-86
Mirrors .....	3-77
Moonroof .....	2-38, 9-20
Multi-function display (color LCD) .....	3-44

**N**

New vehicle break-in driving .....	8-2
------------------------------------	-----

**O**

Odometer .....	3-9
Oil filter .....	11-15
Oil level	
Engine .....	11-13
Front differential gear .....	11-22

Manual transmission .....	11-21
Rear differential gear.....	11-22
Warning light .....	3-17
Oil pressure warning light .....	3-17
Outside	
Mirror defogger.....	3-86
Mirrors.....	3-86
Overheating engine.....	9-12

**P**

Parking	
Brake .....	7-42
Brake stroke.....	11-29
Tips.....	7-45
Periodic inspections .....	8-4
Petrol fuel .....	7-3
PIN code Access .....	2-12
Power	
Door locking switch .....	2-6
Outlets .....	6-8
Outside mirrors.....	3-86
Seat .....	1-5
Steering.....	7-31
Steering fluid.....	11-22, 12-7
Steering warning light.....	3-25
Precautions against vehicle modification.....	1-21, 1-66
Preparing to drive .....	7-8
Push-button	
Ignition switch .....	3-4
Starting and stopping engine.....	7-9

**R**

RAB (Reverse Automatic Braking)	
OFF indicator light.....	3-37
Warning indicator .....	7-75
Warning light .....	3-37
RAB warning indicator .....	7-75
Rear	
Combination lights.....	11-49
Differential gear oil .....	11-22, 12-6
Limited slip differential .....	7-31
Turn signal light .....	11-49
Rear differential	
Oil temperature warning light.....	3-18
Rear seat .....	1-8
Armrest.....	1-11
Folding down .....	1-9
Head restraint adjustment .....	1-8
Rear view camera .....	6-14
Rear window	
Defogger .....	3-86
Recommended	
Brake fluid.....	12-7
Clutch fluid .....	11-24, 12-7
Engine oil .....	12-4
Front differential gear oil .....	12-6
Manual transmission oil.....	12-6
Power steering fluid.....	12-7
Rear differential gear oil.....	12-6
Spark plugs .....	12-8
Refueling.....	7-5
Remote keyless entry system .....	2-18



Replacement		
Access key fob battery .....	11-52	
Brake pad and lining .....	11-28	
Wiper blades .....	11-39	
Replacing		
Access key fob battery .....	11-52	
Air cleaner element .....	11-19	
Battery of access key fob .....	11-52	
Lost transmitters (remote keyless entry system) .....	2-21	
Remote keyless entry transmitter battery .....	11-53	
Replacing bulbs .....	11-44	
Dome light .....	11-51	
Front fog light .....	11-48	
Front side marker light .....	11-47	
Front turn signal light .....	11-47	
Headlight .....	11-44	
License plate light .....	11-50	
Parking light .....	11-47	
Rear combination light .....	11-49	
Rear side marker light .....	11-49	
Rear turn signal light .....	11-49	
Trunk light .....	11-51	
Vanity mirror light .....	11-51	
REV indicator light and buzzer .....	3-12	
Reverse Automatic Braking system .....	7-66	
Rocking the vehicle .....	8-10	
<b>S</b>		
Safety		
Precautions when driving .....	4	
Symbol .....	3	
Warnings .....	2	
Seat		
Fabric .....	10-5	
Front .....	1-2	
Heater .....	1-7	
Height adjustment .....	1-4	
Power .....	1-5	
Rear .....	1-8	
Seatbelt .....	4, 1-12	
Fastening .....	1-13	
Maintenance .....	1-17	
Pretensioners .....	1-17	
Safety tips .....	1-12	
Warning light and chime .....	3-14	
Security		
Indicator light .....	3-33	
Select lever		
Position indicator .....	3-34	
Shift lock function .....	7-26	
Shift-up indicator light .....	3-34	
SI-DRIVE		
Indicator light .....	3-34	
SI-DRIVE mode .....	7-28	
Snow tires .....	8-9, 11-30	
Snowy and icy roads .....	8-8	
Sounding a panic alarm .....	2-20	
Spark plugs .....	11-20, 12-8	
Specifications .....	12-2	
Speedometer .....	3-9	
SRS airbag (Supplemental Restraint System airbag) .....	4, 1-35	

SRS airbag system	
Monitors .....	1-64
Servicing .....	1-65
Warning light .....	3-15
Starting & stopping engine .....	7-9
State emission testing (U.S. only) .....	7-7
Steering lock .....	7-11, 7-14
Steering Responsive Headlight .....	3-71
OFF indicator .....	3-37
OFF indicator light .....	3-37
Warning light .....	3-37
Steering wheel	
Lock .....	7-11, 7-14
Power .....	7-31
Tilt/telescopic .....	3-88
Stop light .....	11-49
Storage compartment .....	6-5
Sun visors .....	6-3
Sunshade .....	2-40
Supplemental Restraint System (SRS) .....	1-35
Supplemental Restraint System airbag (SRS) .....	1-35
Synthetic leather upholstery .....	10-5
<b>T</b>	
Tachometer .....	3-10
Temperature gauge .....	3-11
Temperature warning light	
AT OIL TEMP .....	3-18
Rear differential oil .....	3-18
Temporary spare tire .....	9-2, 12-9

Tether (child restraint system) .....	1-31, 1-34
Tie-down hooks .....	9-13
Tilt/telescopic steering wheel .....	3-88
Tire .....	11-29, 12-8
Chains .....	8-10
Information .....	13-2
Inspection .....	11-31
Pressures and wear .....	11-32
Replacement .....	11-36
Rotation .....	11-35
Size and pressure .....	12-8
Types .....	11-29
Tire pressure monitoring system (TPMS) .....	7-40, 9-8, 11-30
Warning light .....	3-18
Tires and wheels .....	11-29
Tools .....	9-3
Top tether anchorages .....	1-31, 1-34
Towing .....	9-13
All wheels on the ground .....	9-17
Flat-bed truck .....	9-16
Hooks .....	9-13
Trailer	
Towing .....	8-14
Trip meter .....	3-9
Trunk lid .....	2-35
Release handle .....	2-37
Trunk light .....	11-51
Turn signal	
Indicator lights .....	3-35
Lever .....	3-72

**U**

- Under-floor storage compartment..... 6-13
- USB power supply ..... 6-10

**V**

- Vanity mirror..... 6-4
  - Light..... 11-51
- Vehicle
  - Capacity weight ..... 8-11
  - Identification..... 12-16
  - Symbols ..... 4
- Vehicle Dynamics Control
  - OFF indicator light ..... 3-27
  - OFF switch ..... 7-38
  - Operation indicator light..... 3-26, 3-27
  - System ..... 7-37
  - Warning light ..... 3-26
- Ventilator ..... 4-2

**W**

- Warning and indicator lights ..... 3-13
- Warning chimes
  - Keyless access with push-button start system..... 3-28
- Warning indicator
  - RAB ..... 3-37, 7-75
- Warning light
  - ABS ..... 3-20
  - Access key ..... 3-28
  - Access key fob..... 3-29
  - All-Wheel Drive..... 3-25

- AT OIL TEMP ..... 3-18
- Automatic headlight beam leveler..... 3-35
- Brake system..... 3-21
- Charge..... 3-17
- CHECK ENGINE..... 3-16
- Door open ..... 3-25
- Driver's Control Center Differential ..... 3-36
- Engine low oil level..... 3-17
- Hill start assist ..... 3-24
- Keyless access with push-button start system ..... 3-28
- Low fuel ..... 3-24
- Low tire pressure ..... 3-18
- Oil pressure..... 3-17
- Power steering..... 3-25
- Rear differential oil temperature ..... 3-18
- Seatbelt ..... 3-14
- SRS airbag system..... 3-15
- Steering Responsive Headlight ..... 3-37
- Vehicle Dynamics Control..... 3-26
- Windshield washer fluid ..... 3-18
- Warranties..... 1
- Washing..... 10-2
- Waxing and polishing..... 10-3
- Wear indicators ..... 11-34
- Welcome lighting function..... 3-66
- Wheel
  - Alloy ..... 11-37
  - Balance..... 11-34
  - Nut tightening torque ..... 9-4, 12-8, 12-9
  - Replacement ..... 11-37
- Windows ..... 2-31

Windshield	
Washer fluid.....	11-38
Wiper and washer switches .....	3-75
Wiper blades.....	11-39
Wiper deicer.....	3-86
Winter	
Driving.....	8-6
Tires.....	8-9, 11-30
Wiper and washer.....	3-74
Wiper deicer.....	3-86

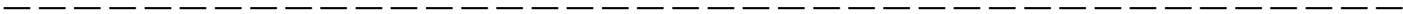
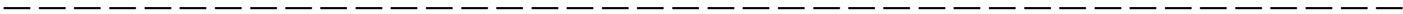
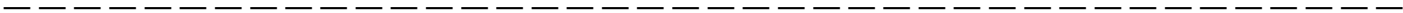
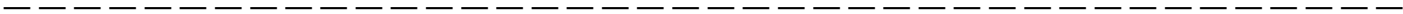
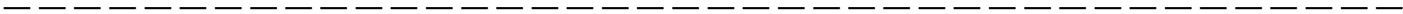
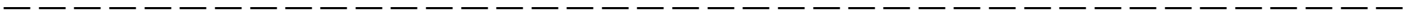
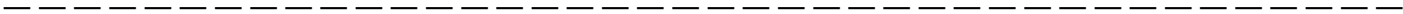
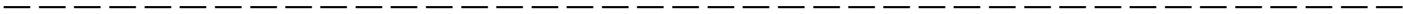
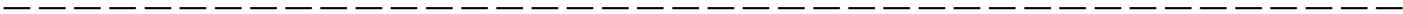
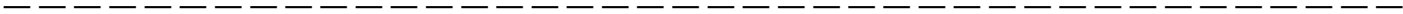
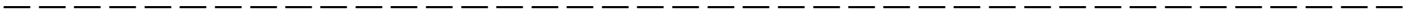
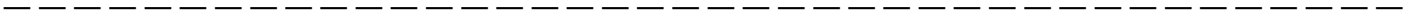
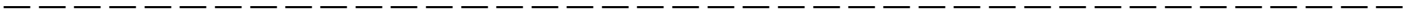

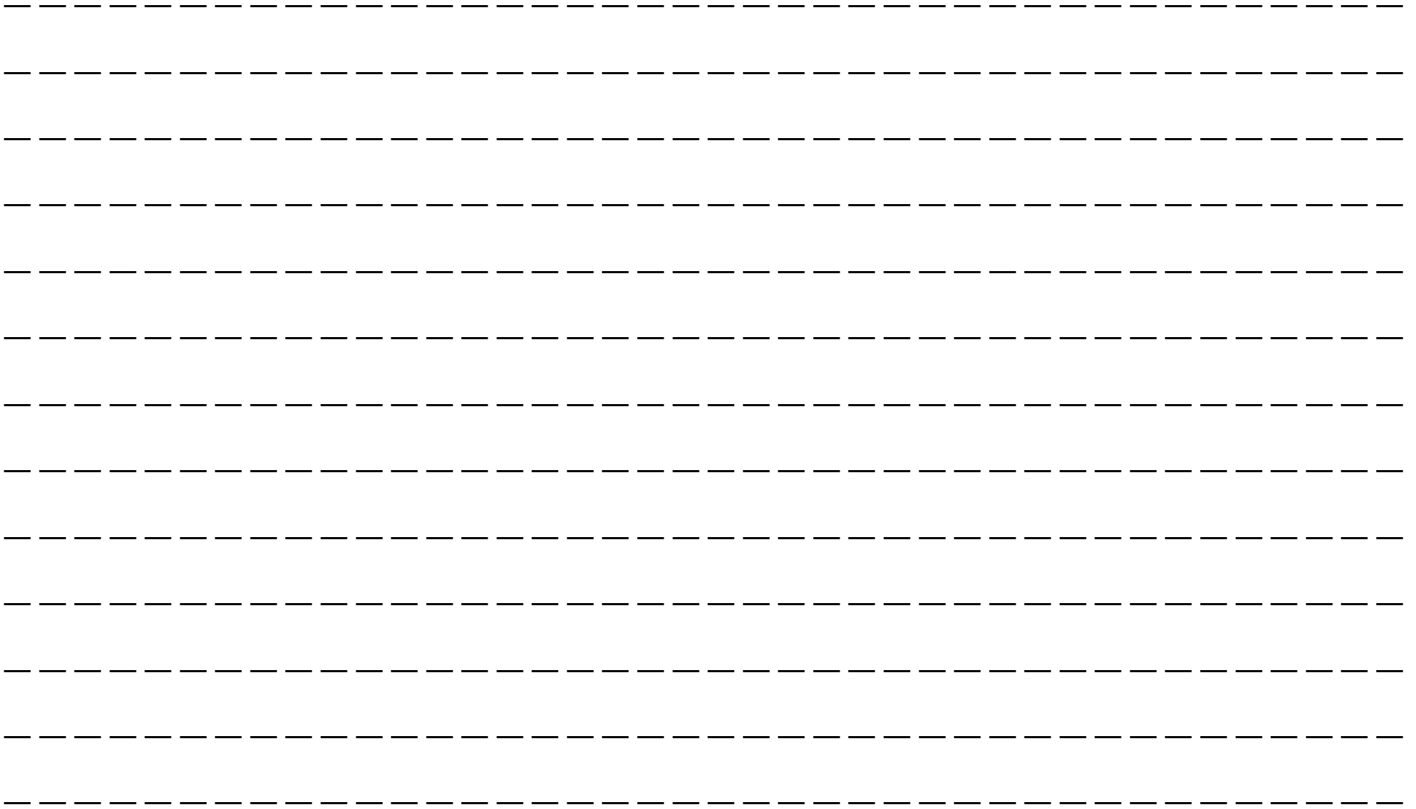

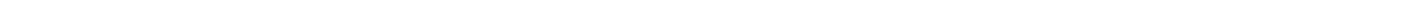
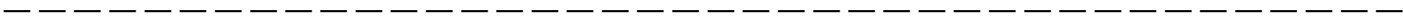
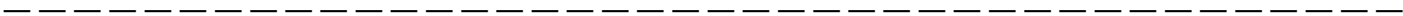
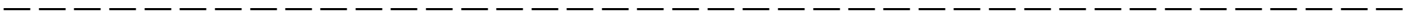
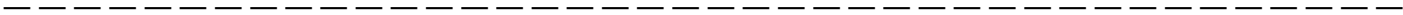
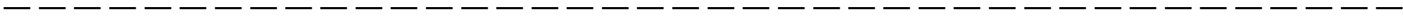
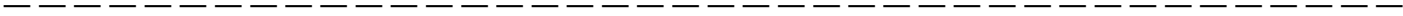

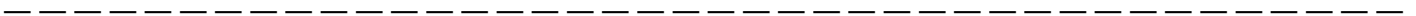
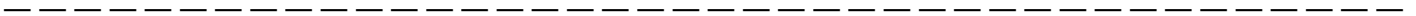
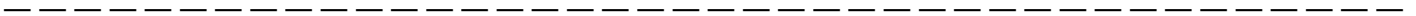
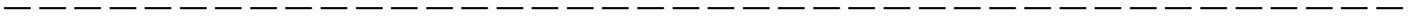
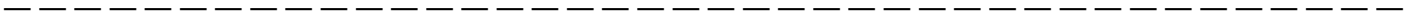
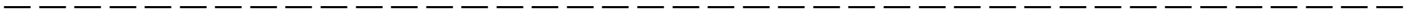
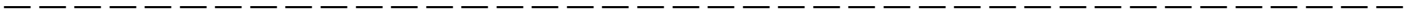
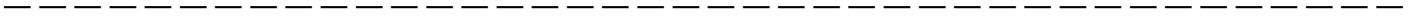
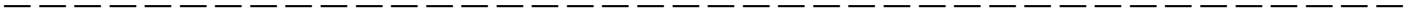



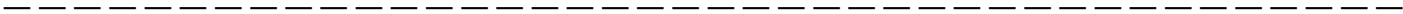
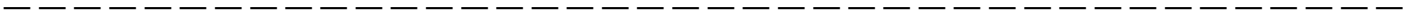
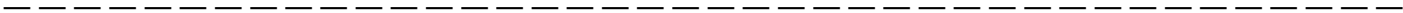
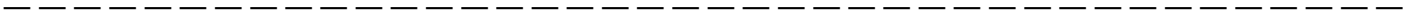
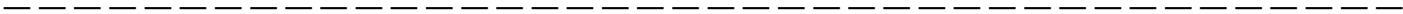
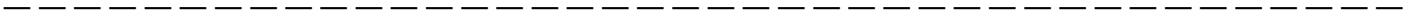
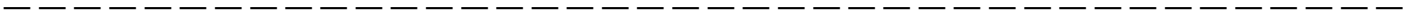
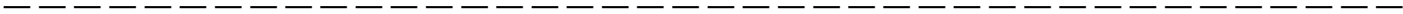
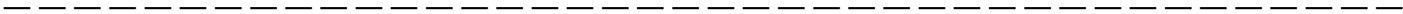
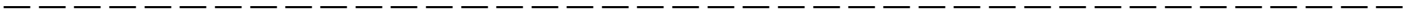
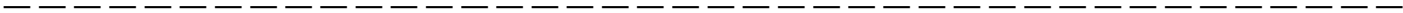
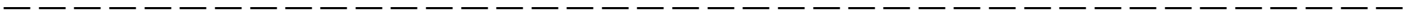
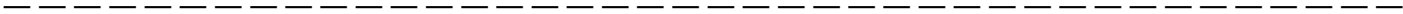

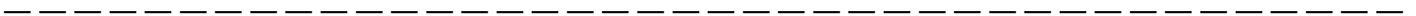
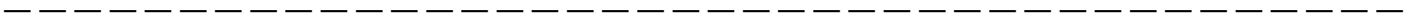
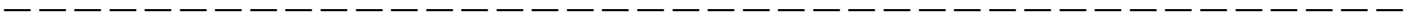
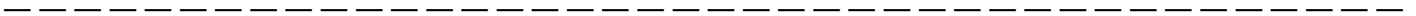
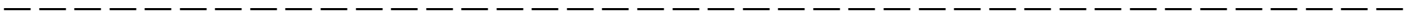
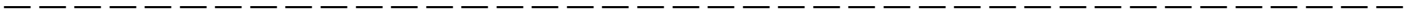
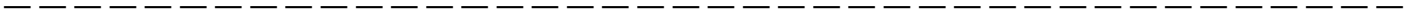
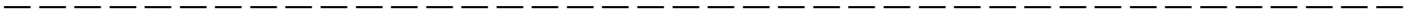
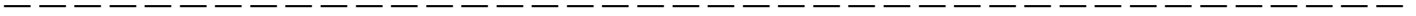

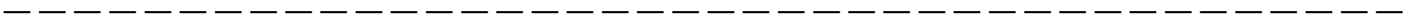
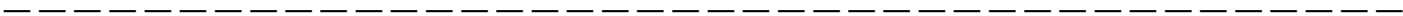
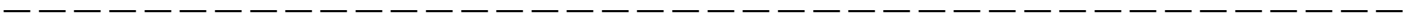
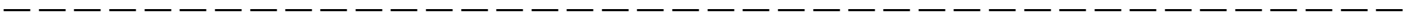
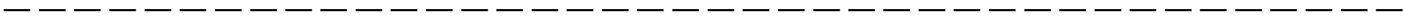
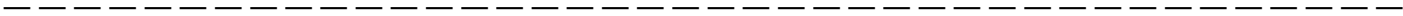
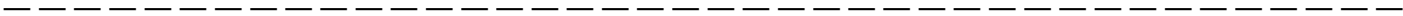
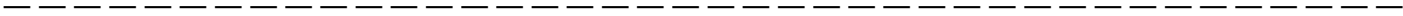
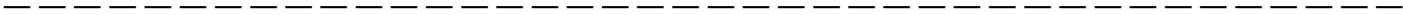
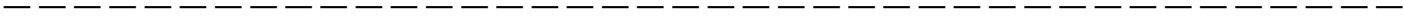
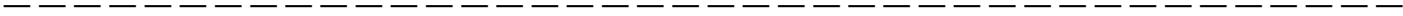

## GAS STATION REFERENCE

---

### ■ Fuel

#### ▼ STI

The engine is designed to operate at maximum performance using **unleaded gasoline** with an octane rating of **93 AKI (98 RON) or higher**. If 93 AKI (98 RON) fuel is not readily available in your area, unleaded gasoline with an octane rating of 91 AKI (95 RON) may be used with no detriment to engine durability or driveability. However, you may notice a slight decrease in maximum engine performance while using 91 AKI (95 RON) fuel. Use of 91 AKI (95 RON) fuel will not affect your warranty coverage.

#### ▼ Except STI

Use **unleaded gasoline** with an octane rating of **91 AKI (95 RON) or higher**. If 91 AKI (95 RON) fuel is not readily available, unleaded gasoline with an octane rating of 87 AKI (90 RON) may be used.

### ■ Fuel octane rating

#### ▼ AKI

This octane rating is the average of the Research Octane and Motor Octane numbers and is commonly referred to as the Anti Knock Index (AKI).

#### ▼ RON

This octane rating is the Research Octane Number.

### ■ Fuel tank capacity

15.9 US gal (60 liters, 13.2 Imp gal)

### ■ Engine oil

Use only the following oils.

- ILSAC GF-5, which can be identified with the ILSAC certification mark (Starburst mark)
- or API classification SN with the words “RESOURCE CONSERVING” or SN PLUS with the words “RESOURCE CONSERVING”

For the complete viscosity requirements, refer to “Engine oil”  12-4.

### ■ Engine oil capacity

#### ▼ STI

4.5 US qt (4.3 liters, 3.8 Imp qt)

#### ▼ Except STI

5.4 US qt (5.1 liters, 4.5 Imp qt)

The indicated oil quantity is only a guideline and is estimated based on a case when the engine oil is changed with an oil filter. Check the oil level using an oil level gauge after refilling the engine with oil. For more details about maintenance and service, refer to “Engine oil”  11-13.

### ■ Cold tire pressure

Refer to “Tires”  12-8.