



2024

**RX450h+**

OWNER'S MANUAL QUICK GUIDE

# Contents

The Quick Guide is not intended as a substitute for your *OWNER'S MANUAL*. We strongly encourage you to review the *OWNER'S MANUAL* and supplementary manuals so you will have a better understanding of your vehicle's capabilities and limitations.

<b>Pictorial Index</b> .....	<b>3</b>
<b>Floor Mat Installation</b>	
Floor Mat Installation.....	11
<b>Plug-in Hybrid System</b>	
Plug-in Hybrid System.....	12
<b>Entering and Exiting</b>	
Keys.....	16
Smart Access System with Push-button Start.....	18
<b>When Driving</b>	
Power (Ignition) Switch.....	19
Transmission.....	22
Turn Signal Lever.....	25
Parking Brake.....	26
Brake Hold.....	28
Multi-information Display.....	29
Displayed content.....	30
Headlights Switch.....	34
AHS (Adaptive High-beam System).....	35
AHB (Automatic High Beam).....	37
Fog Light Switch.....	39
Windshield Wipers and Washer.....	40
Rear Window Wiper and Washer.....	42
Driving Mode Select Switch.....	43

<b>Driving Comfort</b>	
Basic Operation of Multimedia System .....	44
Navigation * .....	45
Connecting a Smartphone or Communication Device * .....	49
Basic Operation of Audio System * .....	55
Lexus Climate Concierge.....	61
Front Automatic Air Conditioning System * .....	62
Rear Air Conditioning System .....	63
<b>Interior features</b>	
Starting Voice Control * .....	64
Connecting a device via the USB port .....	68
<b>Lexus Enform</b>	
Safety Connect .....	69
Remote Connect.....	71
Service Connect.....	72
<b>Opening and Closing</b>	
Side Doors .....	73
Power Windows.....	75
Moon Roof.....	76
Panoramic Moon Roof .....	77
How to Charge .....	79
Power Back Door .....	82
Fuel Tank Cap .....	88
Garage Door Opener .....	89
<b>What to do if...</b>	
List of Warning/Indicator Lights.....	96
If the electronic key does not operate properly .....	100
If the hybrid system doesn't start.....	102
If a door cannot be opened using the door opener switch.....	103

\*: This feature may be operated by Voice command (See P.64)

# Pictorial Index

## Instrument panel

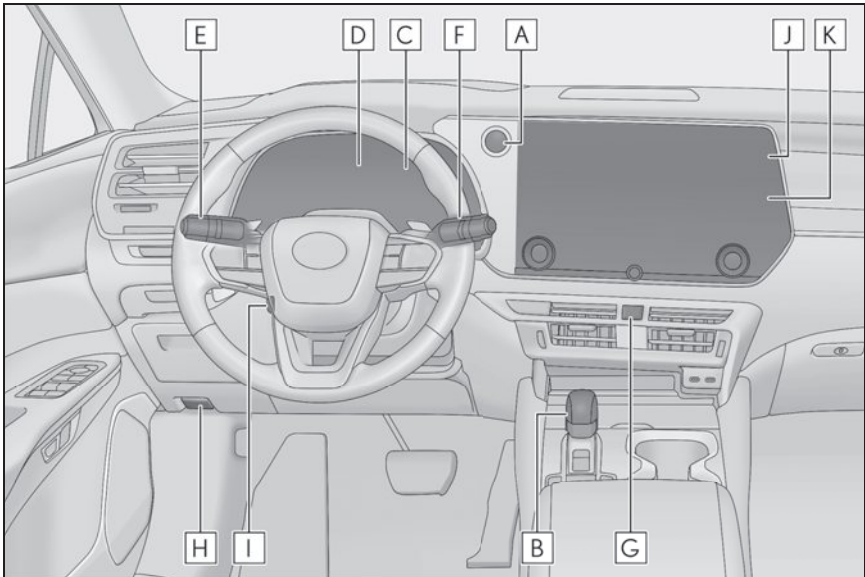

<b>A</b>	<b>Power switch</b> .....	<b>P.19</b>
	Starting the hybrid system/changing the modes .....	P.19
	Emergency stop of the hybrid system .....	P.21
	When the hybrid system will not start.....	P.102
	Warning messages <sup>*1</sup>	
<b>B</b>	<b>Shift lever</b> .....	<b>P.22</b>
	Shifting the shift position.....	P.22
	Precautions for towing <sup>*1</sup>	
<b>C</b>	<b>Meters</b> <sup>*1</sup>	
	Reading the meters/adjusting the instrument panel light <sup>*1</sup>	
	Warning lights/indicator lights.....	P.96
	When a warning light turns on <sup>*1</sup>	
<b>D</b>	<b>Multi-information display</b> .....	<b>P.29</b>
	Display.....	P.29
	Energy monitor.....	P.31
	When the warning messages are displayed <sup>*1</sup>	

<b>E</b>	<b>Turn signal lever</b> .....	P.25
	<b>Headlight switch</b> .....	P.34
	Headlights/side marker lights/parking lights/tail lights/ license plate lights/daytime running lights .....	P.34
	Front fog lights .....	P.39
<b>F</b>	<b>Windshield wiper and washer switch</b> .....	P.40, 42
	Usage .....	P.40, 42
	Adding washer fluid <sup>*1</sup>	
	Warning messages <sup>*1</sup>	
<b>G</b>	<b>Emergency flasher switch</b> <sup>*1</sup>	
<b>H</b>	<b>Hood lock release lever</b> <sup>*1</sup>	
<b>I</b>	<b>Tilt and telescopic steering control switch</b> <sup>*1</sup>	
	Adjustment <sup>*1</sup>	
	Driving position memory <sup>*1,2</sup>	
<b>J</b>	<b>Air conditioning system</b> .....	P.62, 63
	Usage .....	P.62, 63
	Rear window defogger <sup>*1</sup>	
<b>K</b>	<b>Audio system</b> <sup>*3</sup>	

\*1: Refer to the "OWNER'S MANUAL".

\*2: If equipped

\*3: Refer to the "MULTIMEDIA OWNER'S MANUAL".

## ■ Switches

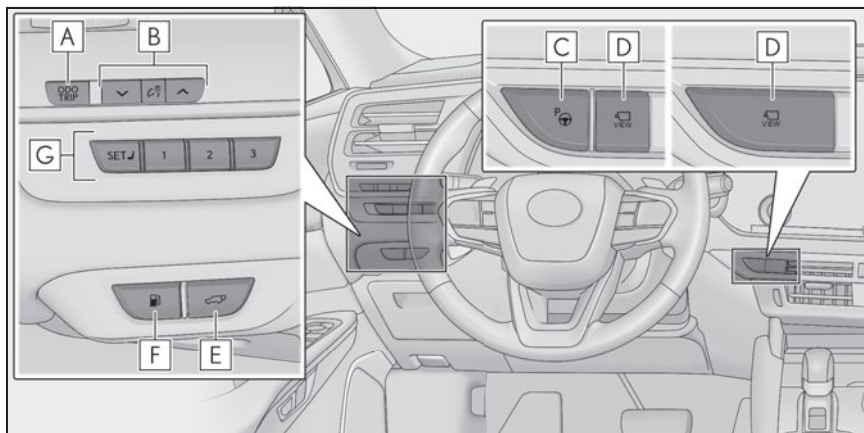

**A** “ODO TRIP” switch \*1

**B** Instrument panel light control switches \*1

**C** Advanced Park (parking assist system) main switch \*1,2

**D** Camera switch \*2,3

**E** Power back door switch ..... P.82

**F** Fuel filler door opener switch ..... P.88

**G** Driving position memory switches \*1,2

\*1: Refer to the “OWNER’S MANUAL”.

\*2: If equipped

\*3: Refer to the “MULTIMEDIA OWNER’S MANUAL”.

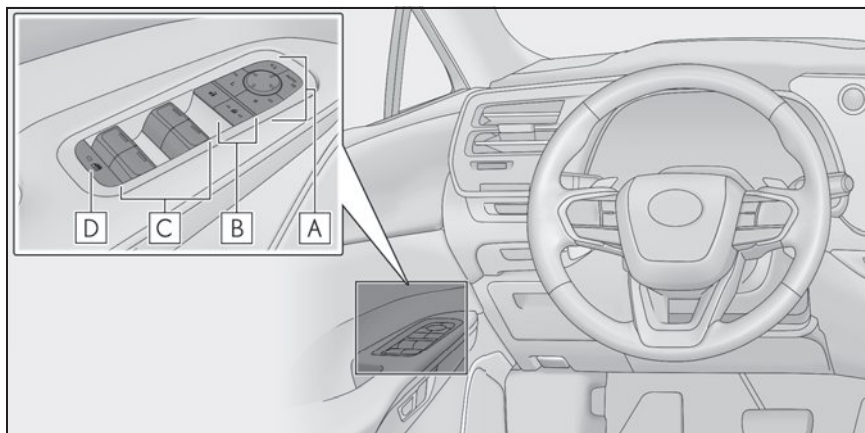

- A** Outside rear view mirror switches \*
- B** Door lock switches..... P.73
- C** Power window switches..... P.75
- D** Window lock switch..... P.75

\*: Refer to the "OWNER'S MANUAL".

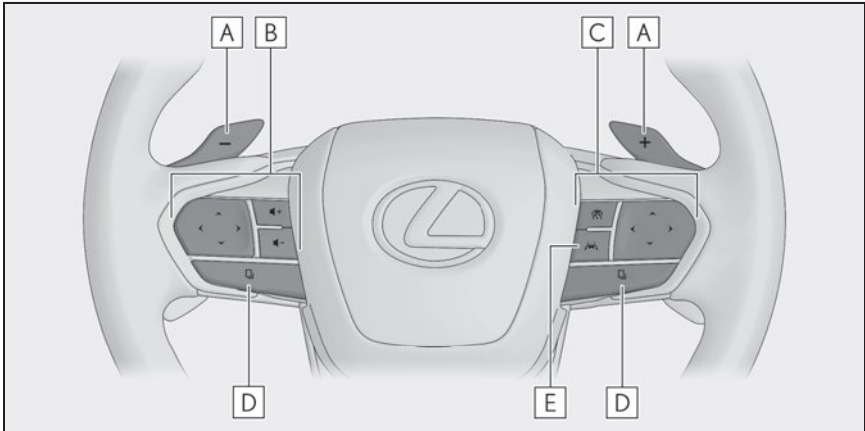

- A** Paddle shift switches ..... P.23
- B** Audio remote control switches/telephone switch/talk switch<sup>\*2</sup>
- C** Cruise control switch
  - Dynamic radar cruise control<sup>\*1</sup>
  - Cruise control<sup>\*1</sup>
- D** Switch function change switch ..... P.30
- E** LTA (Lane Tracing Assist) switch<sup>\*1</sup>

<sup>\*1</sup>: Refer to the "OWNER'S MANUAL".

<sup>\*2</sup>: Refer to the "MULTIMEDIA OWNER'S MANUAL".



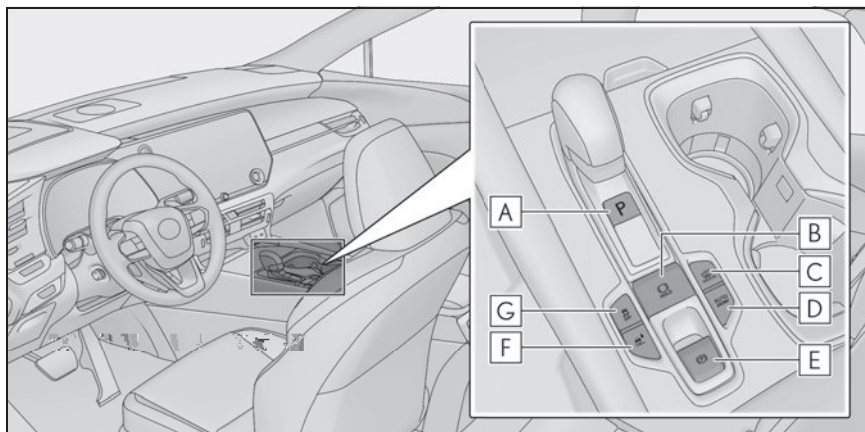

<b>A</b>	P position switch.....	P.22
<b>B</b>	Brake hold switch .....	P.28
<b>C</b>	EV/HV mode selection switch .....	P.14
<b>D</b>	AUTO EV/HV mode switch .....	P.14
<b>E</b>	Parking brake switch.....	P.26
	Applying/releasing.....	P.26
	Precautions for winter season*	
	Warning buzzer/messages*	
<b>F</b>	Trail Mode switch*	
<b>G</b>	VSC OFF switch*	

\*: Refer to the "OWNER'S MANUAL".

## Interior

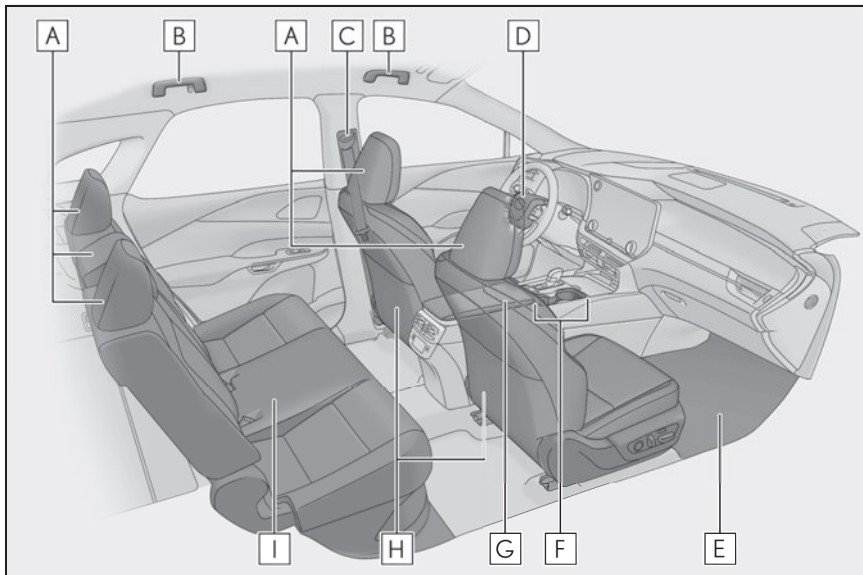

**A** Head restraints\*

**B** Assist grips\*

**C** Seat belts\*

**D** SRS airbags\*

**E** Floor mats ..... P.11

**F** Cup holders\*

**G** Console box\*

**H** Front seats\*

**I** Rear seats\*

\*: Refer to the "OWNER'S MANUAL".

## ■ Ceiling

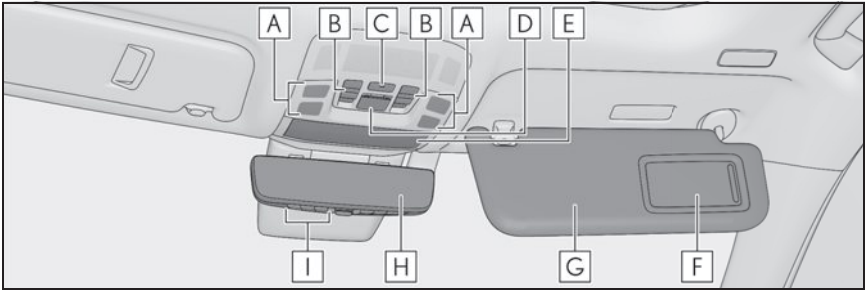

- A** Interior light<sup>\*1</sup>  
Personal lights<sup>\*1,2</sup>
- B** Moon roof switches<sup>\*3</sup> ..... P.76  
Panoramic moon roof switches<sup>\*3</sup> .....P.77
- C** Door-linked interior light switch<sup>\*1</sup>
- D** "SOS" button<sup>\*1,3</sup>
- E** Auxiliary box<sup>\*1</sup>
- F** Vanity mirrors<sup>\*1</sup>
- G** Sun visors<sup>\*1</sup>
- H** Inside rear view mirror<sup>\*1,3</sup>  
Digital Rearview Mirror<sup>\*1,3</sup>
- I** Garage door opener switches ..... P.89

\*1: Refer to the "OWNER'S MANUAL".

\*2: The illustration shows the front, but they are also equipped in the rear.

\*3: If equipped

## Floor Mat Installation

Use only floor mats designed specifically for vehicles of the same model and model year as your vehicle. Fix them securely in place onto the carpet.

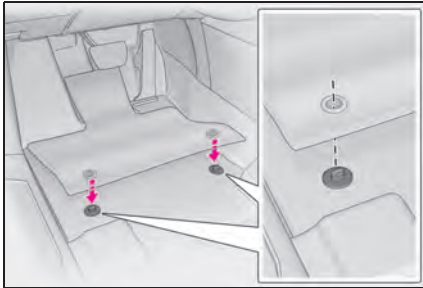

- 1 Insert the retaining hooks (clips) into the floor mat eyelets.

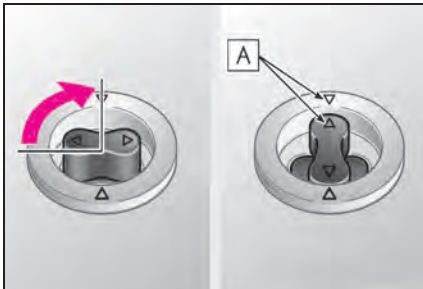

- 2 Turn the upper knob of each retaining hook (clip) to secure the floor mats in place.

Always align the  $\triangle$  marks **A**.

The shape of the retaining hooks (clips) may differ from that shown in the illustration.

## Plug-in Hybrid System

Your vehicle is a hybrid electric vehicle. It has characteristics different from conventional vehicles. Be sure you are closely familiar with the characteristics of your vehicle, and operate it with care.

The hybrid system combines the use of a gasoline engine and an electric motor (traction motor) according to driving conditions, improving fuel efficiency and reducing exhaust emissions.

For details, refer to the “Owner’s Manual”.

## Hybrid System Indicator

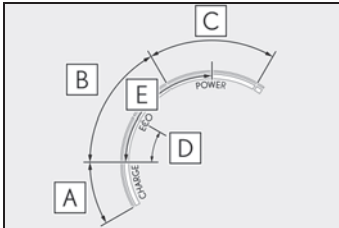

This illustration is for explanation only and may differ depending on the specifications of the vehicle.

- A** Charge area  
Shows regeneration\* status.
- B** Eco area  
Shows that the vehicle is being driven in an Eco-friendly manner.
- C** Power area  
Shows that an Eco-friendly driving range is being exceeded (during full power driving etc.)
- D** Hybrid Eco area (HV mode)  
Shows that gasoline engine power is not being used very often.  
The gasoline engine will automatically stop and restart under various conditions.
- E** EV driving area (EV mode or AUTO EV/HV mode)  
Shows that the vehicle is driven using only the electric motor (traction motor).
  - By keeping the indicator needle within Eco area, more Eco-friendly driving can be achieved.

- Charge area indicates regeneration\* status. Regenerated energy will be used to charge the hybrid battery (traction battery).

\*: When used in this manual, regeneration refers to the conversion of energy created by the movement of the vehicle into electrical energy.

## Hybrid battery (traction battery) charge

If the shift position is in N, the hybrid battery (traction battery) will not be charged. To help prevent the battery from discharging, avoid leaving the N position selected for a certain amount of time.

## Sounds and vibrations specific to a hybrid electric vehicle

Because there is no engine sound or vibration, it is easy to mistake the hybrid electric vehicle for being off when it is actually still running, as indicated by the “READY” indicator being illuminated. For safety, make sure to always shift the shift position to P and apply the parking brake when parked.

The following sounds or vibrations may occur when the hybrid system is operating and are not a malfunction.

- Motor sounds may be heard from the engine compartment.
- Sounds may be heard from the hybrid battery (traction battery) when the hybrid system starts or stops.
- Click or clunk sounds that may be heard from under of the floor or the rear when the hybrid system is started or stopped, which are sounds of high voltage relay.
- Sounds from the hybrid system may be heard when the back door is open.
- Sounds may be heard from the transmission when the gasoline engine starts or stops, when driving at low speeds, or during idling.
- Engine sounds may be heard when accelerating sharply.
- Sounds may be heard due to regenerative braking when the brake pedal is depressed or as the accelerator pedal is released.
- Vibration may be felt when the gasoline engine starts or stops.
- Cooling fan sounds may be heard from the air intake vent under the rear seat.
- Sounds may be heard from near the hybrid battery (traction battery) in accordance with the operation of the air conditioning system or battery cooler.

## Switching the plug-in hybrid system operation modes

Press the AUTO EV/HV mode switch or EV/HV mode selection switch to change modes as the following table shows.

When in EV mode, the EV drive mode indicator illuminates.

When in AUTO EV/HV mode, the AUTO EV/HV mode indicator illuminates.

When in HV mode, the HV drive mode indicator illuminates.

### ► AUTO EV/HV mode switch

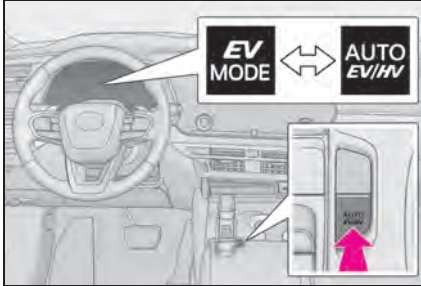

Current mode	Mode after switching
EV mode	AUTO EV/HV mode
AUTO EV/HV mode	EV mode
HV mode	AUTO EV/HV mode*

\*: If there is not enough charge remaining in the hybrid battery (traction battery) to allow EV driving, AUTO EV/HV mode will not be selectable.

### ► EV/HV mode selection switch

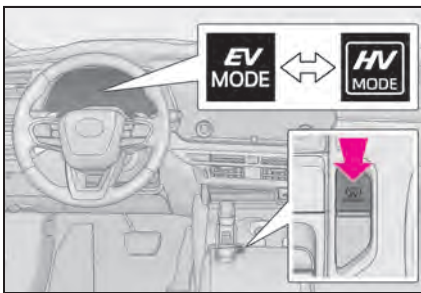

Current mode	Mode after switching
EV mode	HV mode
AUTO EV/HV mode	HV mode
HV mode	EV mode*

\*: If there is not enough charge remaining in the hybrid battery (traction battery) to allow EV driving, EV mode will not be selectable.

## Switching to the hybrid battery (traction battery) charge mode

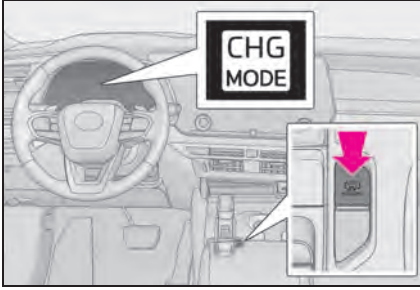

Press and hold the EV/HV mode selection switch.

Take your hand off the switch once the hybrid battery charge mode indicator starts to blink.

The hybrid battery charge mode indicator illuminates when the switch to hybrid battery (traction battery) charge mode is complete.

When the charge of the hybrid battery (traction battery) reaches the specified level, battery charge mode is released automatically to change to HV mode.

The hybrid battery (traction battery) charge mode will be canceled by pressing AUTO EV/HV mode switch or EV/HV mode selection switch.

\*: The specified charge level in battery charge mode is approximately 80% of the fully charged level.



# Keys

## The keys

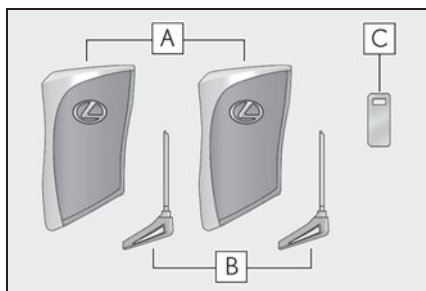

**A** Electronic keys

- Operating the smart access system with push-button start
- Operating the wireless remote control function

**B** Mechanical keys

**C** Key number plate

## Wireless remote control

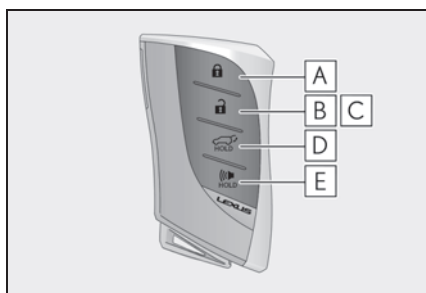

**A** Locks all the doors

**B** Unlocks all the doors

**C** Opens the windows<sup>\*2</sup> and the moon roof<sup>\*1,2</sup> or panoramic moon roof<sup>\*1,2</sup>

**D** Opens and closes the power back door

**E** Sounds the alarm

\*1: If equipped

\*2: These settings must be customized at your Lexus dealer.

## Mechanical key

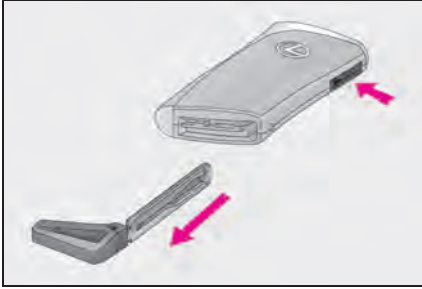

To take out the mechanical key, push the release button and take the key out.

The mechanical key can only be inserted in one direction, as the key only has grooves on one side. If the key cannot be inserted in a lock cylinder, turn it over and re-attempt to insert it.

After using the mechanical key, store it in the electronic key. Carry the mechanical key together with the electronic key. If the electronic key battery is depleted or the entry function does not operate properly, you will need the mechanical key.

## Smart Access System with Push-button Start

The following operations can be performed simply by carrying the electronic key on your person, for example in your pocket. The driver should always carry the electronic key. For details on starting the engine, see page 19.

### Unlocking and locking the doors from the outside

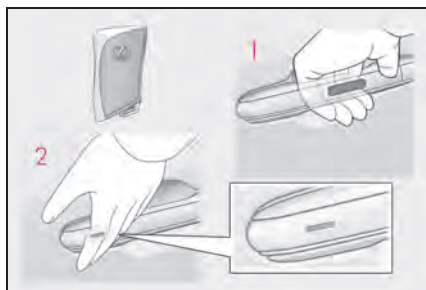

- 1 Grip the driver's door handle to unlock the door. Grip any passenger door handle to unlock all the doors.\*

Make sure to touch the sensor on the back of the handle.

The doors cannot be unlocked for 3 seconds after the doors are locked.

- \*: The door unlock settings can be changed.

- 2 Touch the lock sensor (indentation on the surface of the door handle) to lock all the doors.

Check that the door is securely locked.

### Unlocking and locking the power back door from the outside

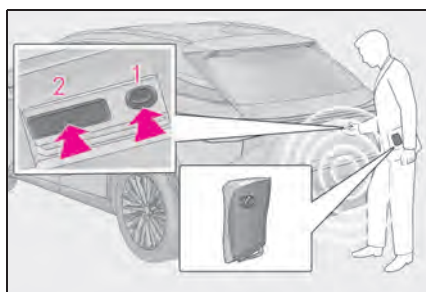

- 1 Locks all the doors  
Check that the door is securely locked.
- 2 Unlocks all the doors  
The doors cannot be unlocked for 3 seconds after the doors are locked.

For details on what to do when the electronic key does not operate properly, see page 100.

## Power (Ignition) Switch

Performing the following operations when carrying the electronic key on your person starts the hybrid system or changes Power switch modes.

### Starting the hybrid system

- 1 Check that the AC charging cable is disconnected.
- 2 Pull the parking brake switch to check that the parking brake is set.  
The parking brake indicator will come on.
- 3 Firmly depress the brake pedal.



and a message will be displayed on the multi-information display.

If it is not displayed, the hybrid system cannot be started.

When the shift position is N, the hybrid system cannot start.

Shift the shift position to P when starting the hybrid system.



- 4 Press the power switch shortly and firmly.

When operating the power switch, one short, firm press is enough. It is not necessary to press and hold the switch.

If the "READY" indicator turns on, the hybrid system will operate normally.

Continue depressing the brake pedal until the "READY" indicator is illuminated.

The hybrid system can be started from any power switch mode.

- 5 Check that the "READY" indicator is illuminated.

The vehicle will not move when the "READY" indicator is off.

## Stopping the hybrid system

- 1 Stop the vehicle completely.
- 2 Set the parking brake.
- 3 Press the P position switch.  
Check that the shift position indicator shows P and the parking brake indicator is illuminated.
- 4 Press the power switch.  
The hybrid system will stop, and the meter display will be extinguished (the shift position indicator will be extinguished a few seconds after the meter display).
- 5 Release the brake pedal and check that ACC or ON is not shown on the meter.

## Changing Power switch modes

Modes can be changed by pressing the power switch with brake pedal released. (The mode changes each time the switch is pressed.)

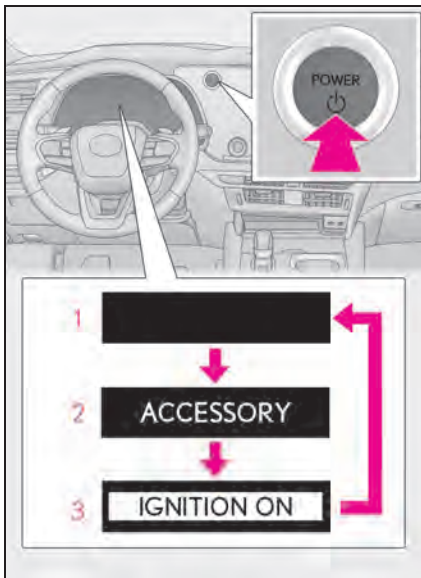

- 1 Off  
The emergency flashers can be used.
  - 2 ACC\*  
Some electrical components such as the audio system can be used.
  - 3 ON  
All electrical components can be used.
- \*: ACC mode can be enabled/disabled on the customize menu.

## If your vehicle has to be stopped in an emergency

Only in an emergency, such as if it becomes impossible to stop the vehicle in the normal way, stop the vehicle using the following procedure:

- 1 Steadily step on the brake pedal with both feet and firmly depress it.  
Do not pump the brake pedal repeatedly as this will increase the effort required to slow the vehicle.
- 2 Shift the shift position to N.  
▶ **If the shift position is shifted to N**
- 3 After slowing down, stop the vehicle in a safe place by the road.
- 4 Stop the hybrid system.
- ▶ **If the shift position cannot be shifted to N**
- 3 Keep depressing the brake pedal with both feet to reduce vehicle speed as much as possible.

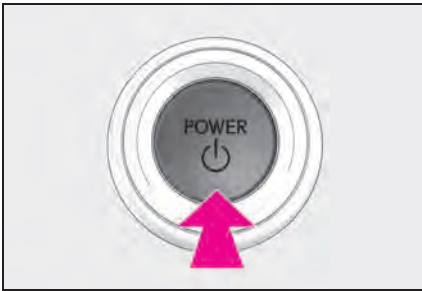

- 4 To stop the hybrid system, press and hold the power switch for 2 consecutive seconds or more, or press it briefly 3 times or more in succession.

- 5 Stop the vehicle in a safe place by the road.

# Transmission

## Shift position display and how to change the shift position

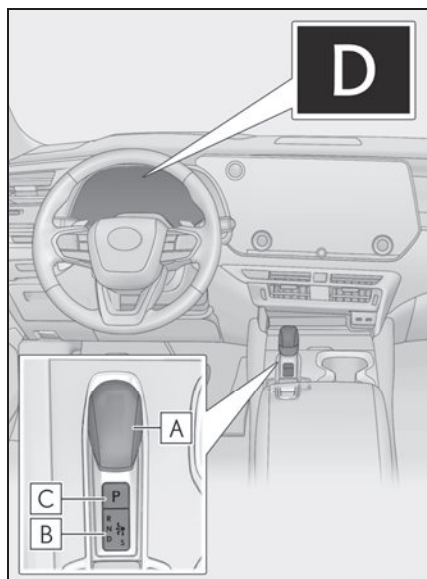

### A Shift lever

Operate the shift lever gently and securely in the direction of the arrow on the shift position indicator.

To shift to N, slide the shift lever in the direction of the arrow and hold it.

Release the shift lever after each shifting operation to allow it to return to its regular position (●).

Shifting to S is only possible when the shift position is in D.

When shifting from P to N, D or R, from N, D, S or R to P, from D or S to R, or from R to D, ensure that the brake pedal is being depressed and the vehicle is stationary.

### B Shift position indicator

Meter display:

The current shift position is illuminated.

Shift lever display:

The current shift position is illuminated.

When selecting the shift position, make sure that the shift position has been changed to the desired position by checking the shift position indicator provided on the instrument cluster.

### C P position switch

Fully stop the vehicle and set the parking brake, and then press the P position switch.

When the shift position is changed to P, the switch illuminates.

Check that the shift position indicator shows P.

Shift position	Objective or function
P	Parking the vehicle/starting the hybrid system
R	Reversing
N	Neutral (Condition in which the power is not transmitted)
D	Normal driving <sup>*1</sup>
S	S mode driving <sup>*2</sup>

<sup>\*1</sup>: To improve fuel efficiency and reduce noise, set the shift position in D for normal driving. You can choose gear range suitable for your driving situation by operating the paddle shift switches.

<sup>\*2</sup>: By selecting shift ranges using S mode, you can control accelerating force and engine braking force.

## Selecting the driving mode

### ■ Driving mode

→P.43

## Selecting shift ranges in the D position

To drive using temporary shift range selection, operate the “-” paddle shift switch. Changing the shift range enables the level of engine braking force to be selected. The shift range can then be selected by operating the “-” and “+” paddle shift switches.

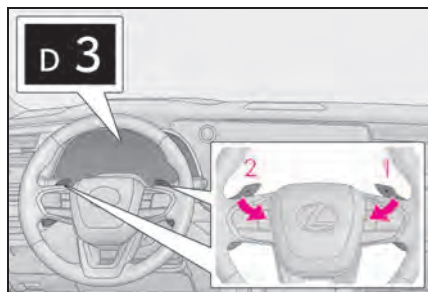

**1** Upshifting

**2** Downshifting

The selected shift range, from D1 to D5, will be displayed on the meter.

The initial shift range when the “-” paddle shift switch is operated is automatically set to D4.

To return to normal D position driving, hold the “+” paddle shift switch for a period of time or operate the “+” paddle shift switch in the D5 range.

### ■ Shift ranges and their functions

- You can choose from 5 levels of engine braking force.
- A lower shift range will provide greater engine braking force than a higher shift range, and the engine revolutions will also increase.



## Selecting gears in the S position

To enter S mode, shift the shift position to S. Gears can be selected by operating the paddle shift switches, allowing you to drive in the gear of your choosing. The shift range can then be selected by operating the “-” and “+” paddle shift switches.

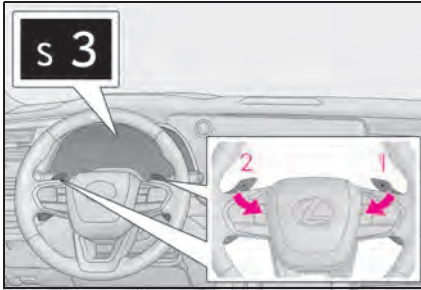

**1** Upshifting

**2** Downshifting

The selected shift range, from S1 to S6, will be displayed on the meter.

The initial shift range in S mode is automatically set to S4\*.

\*: It is set to S3 when the driving mode is set to sport mode.

### ■ Shift ranges and their functions

- You can choose from 6 levels of accelerating force and engine braking force.
- A lower shift range will provide greater accelerating force and engine braking force than a higher shift range, and the engine revolutions will also increase.

## Turn Signal Lever

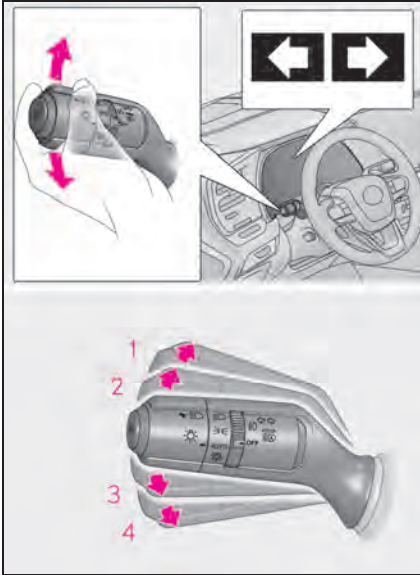

- 1** Right turn
- 2** Lane change to the right (move the lever partway and release it)  
The right hand signals will flash 3 times.
- 3** Lane change to the left (move the lever partway and release it)  
The left hand signals will flash 3 times.
- 4** Left turn

# Parking Brake

The parking brake can be set or released automatically or manually.

In automatic mode, the parking brake can be set or released automatically according to the shift lever operation.

Also, even in automatic mode, the parking brake can be set or released manually.

## Using the manual mode

The parking brake can be set and released manually.

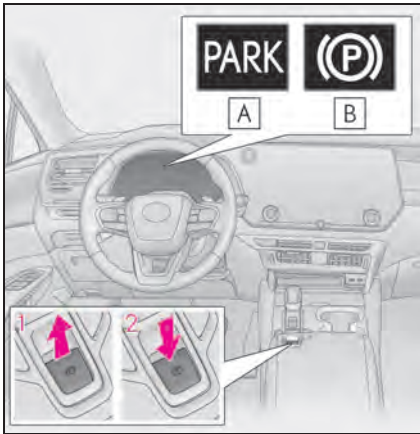

**A** Parking brake indicator (U.S.A.)

**B** Parking brake indicator (Canada)

**1** Pull the switch to set the parking brake.

The parking brake indicator light will turn on.

Pull and hold the parking brake switch if an emergency occurs and it is necessary to operate the parking brake while driving.

**2** Press the switch to release the parking brake.

- Operate the parking brake switch while depressing the brake pedal.
- Using the parking brake automatic release function, the parking brake can be released by depressing the accelerator pedal. When using this function, slowly depress the accelerator pedal.

Make sure that the parking brake indicator light turn off.

If the parking brake indicator light flash, operate the switch again.

## Turning the automatic mode on

While the vehicle is stopped, pull and hold the parking brake switch until a buzzer sounds and a message is shown on the multi-information display.

When the automatic mode is turned on, the parking brake operates as follows.

- When the shift position is shifted from P, the parking brake will be released, and the parking brake indicator light will turn off.
- When the shift position is shifted to P, the parking brake will be set, and the parking brake indicator light will turn on.

Operate the shift lever and P position switch with the vehicle stopped and the brake pedal depressed.

The auto function may not operate if the shift lever is moved extremely quickly. In this situation, apply the parking brake manually.

## Turning the automatic mode off

While the vehicle is stopped and depressing the brake pedal, press and hold the parking brake switch until a buzzer sounds and a message is shown on the multi-information display.

## Brake Hold

The brake hold system keeps the brake applied when the shift position is in D, S or N with the system on and the brake pedal has been depressed to stop the vehicle. The system releases the brake when the accelerator pedal is depressed with the shift position in D or S to allow smooth start off.

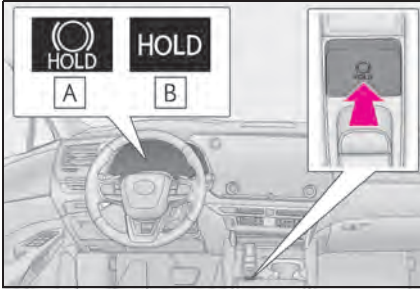

Turns the brake hold system on

The brake hold standby indicator (green)

**A** comes on. While the system is holding the brake, the brake hold operated indicator (yellow) **B** comes on.

# Multi-information Display

## Displayed contents summary

A variety of driving-related information can be displayed. Depending on the situation, warning or advice pop-up displays will also be displayed.

### ■ Items displayed in the content display area

The following items can be displayed.

- Drive information 1
- Drive information 2
- Energy monitor/EV driving ratio
- Audio system-linked display
- Navigation system-linked display\*
- G-force
- Driving support system information display\*
- Blank (No items)

\*: Displayed on the head-up display when the display mode is set to display the maximum.

If a problem is detected in any of the vehicle's systems, a warning message is shown on the multi-information display.

# Displayed content

## Components/Operations

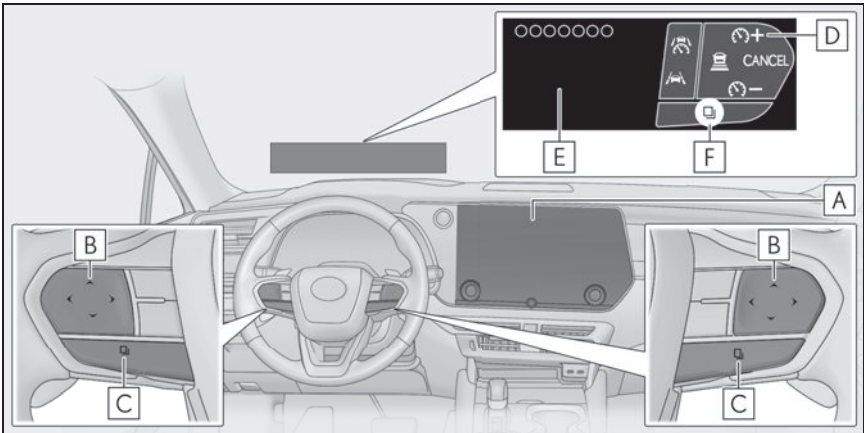

**A** Center display

**B** Steering switch

The function of each switch differs depending on the conditions and settings.

When a switch is touched, the function of each switch is displayed on the head-up display. If the head-up display is off, or when it is not possible to display content on the head-up display, the functions will be displayed on the multi-information display.

Also, preferred functions for each switch can be set on the center display.

**C** Switch function change switch

Each time this switch is pressed, the functions will change.

**D** Switch icon display

The icon of each switch will be displayed. The touched switch will be highlighted. (**F**)

**E** Switch function guide display

The function guide for the touched switch will be displayed.

The head-up display may seem dark or hard to see when viewed through sunglasses, especially polarized sunglasses.

Adjust the brightness of the head-up display or remove your sunglasses.

## Energy monitor/EV driving ratio (If equipped)

The energy monitor and EV driving ratio can be displayed on the multi-information display.

The energy monitor screen can be displayed on the center display.

### ■ Displaying Energy monitor screen on the center display

1 Select  on the main menu.

2 Select “Energy flow”.

### ■ Energy monitor

The energy monitor can be used to check the vehicle drive status, hybrid system operation status and energy regeneration status.

The arrows will appear in accordance with the energy flow. When there is no energy flow, arrows will not be displayed.

The color of the arrows will change as follows.

- Blue: When the hybrid battery (traction battery) is regenerated or charged.
- Orange: When the hybrid battery (traction battery) is in use.
- Red: When the gasoline engine is in use.

The image shows all the arrows as an example. The actual display will vary depending on conditions.

#### ► Multi-information display

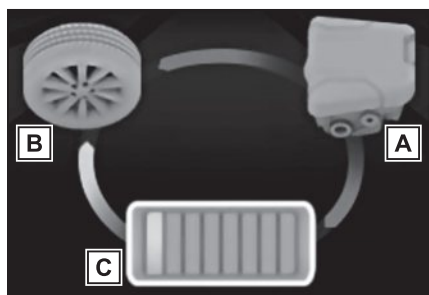

- A** Gasoline engine
- B** Tires
- C** Hybrid battery (traction battery)

This illustration is for explanation only and may differ depending on the specifications of the vehicle.

#### ► Center display (except when charging)

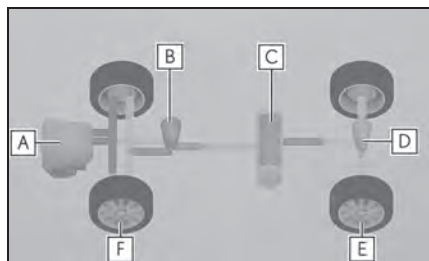

- A** Gasoline engine
- B** Front electric motor (traction motor)
- C** Hybrid battery (traction battery)
- D** Rear electric motor (traction motor)
- E** Rear tires
- F** Front tires



### ► Center display (when charging)

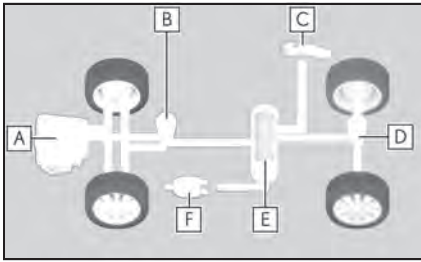

- A** Gasoline engine
- B** Front electric motor (traction motor)
- C** Charging connector
- D** Rear electric motor (traction motor)
- E** Hybrid battery (traction battery)
- F** Power outlet (120 VAC) (if equipped)

### ■ EV driving ratio since starting (If equipped)

Displays the percentage of EV driving since starting.

It is reset each time the hybrid system stops.

## Current fuel consumption/history screen

Fuel consumption information can be displayed on the center display.

### ■ Displaying fuel consumption/history screen on the center display

- 1 Select  on the main menu.
- 2 Select "Trip information".
- 3 Select "Current" or "History".

### ■ Current fuel consumption screen

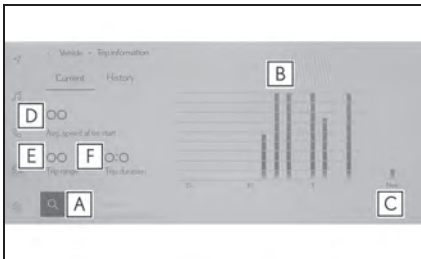

- A** Resetting the history data
- B** Fuel consumption in the past 15 minutes
- C** Current fuel consumption
- D** Average vehicle speed since the hybrid system was started.
- E** Trip range
- F** Elapsed time since the hybrid system was started.

Use the displayed average fuel consumption as a reference. The image is an example only, and may vary slightly from actual conditions.

## History fuel consumption screen

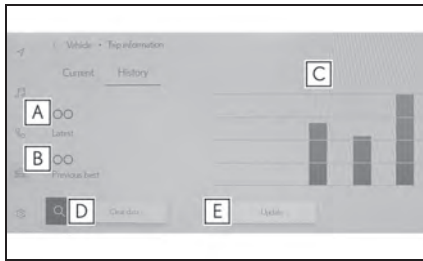

- A** Latest fuel consumption
- B** Best recorded fuel consumption
- C** Previous fuel consumption record
- D** Resetting the history data
- E** Updating the latest fuel consumption data

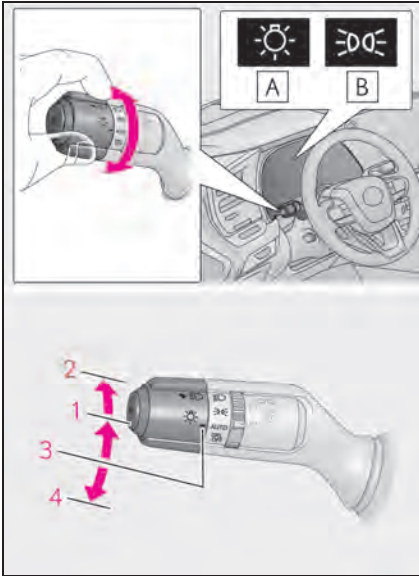

Use the displayed average fuel consumption as a reference. The image is an example only, and may vary slightly from actual conditions.

## Headlights Switch



**A** U.S.A.

**B** Canada

- 1**  The side marker, parking, tail, license plate, instrument panel lights, and daytime running lights turn on.
- 2**  The headlights and all lights listed above (except daytime running lights) turn on.
- 3** **AUTO** The headlights, daytime running lights and all the lights listed above turn on and off automatically. (When the power switch is in ON.)
- 4**  (U.S.A.) Off

## Turning on the high beam headlights

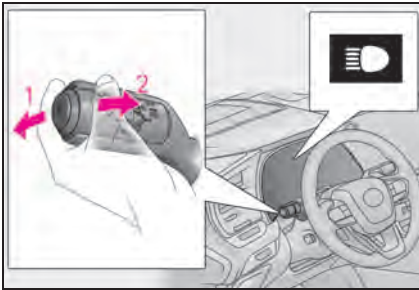

- 1** With the headlights on, push the lever away from you to turn on the high beams.  
Pull the lever toward you to the center position to turn the high beams off.
- 2** Pull the lever toward you and release it to flash the high beams once.  
You can flash the high beams with the headlights on or off.

## AHS (Adaptive High-beam System) (if equipped)

The Adaptive High-beam System uses a front camera located on the upper portion of the windshield to detect the brightness of the lights of vehicles ahead, streetlights, etc., and automatically controls the light distribution of the headlights.

### Using the Adaptive High-beam System

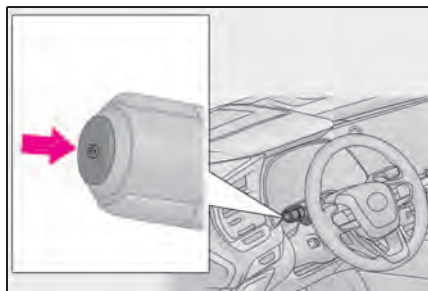

- 1 Press the Adaptive High-beam System switch.

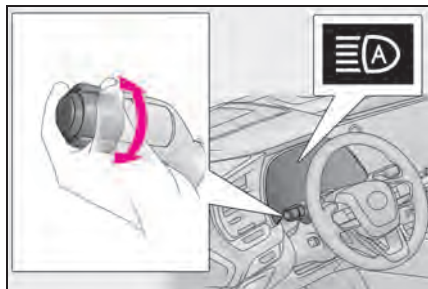

- 2 Turn the headlight switch to the AUTO or  position.

When the headlight switch lever is in the low beam position, the AHS will be enabled and the AHS indicator will illuminate.

## Turning the high beams on/off manually

### ■ Changing to the high beams

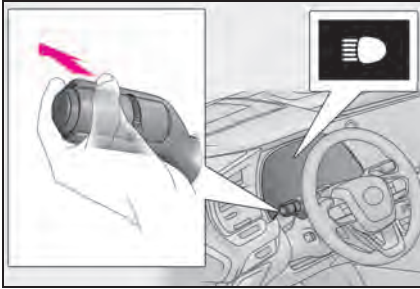

Push the lever forward.

The AHS indicator will turn off and the high beam indicator will turn on.

Pull the lever to its original position to enable the Adaptive High-beam System again.

### ■ Changing to the low beams

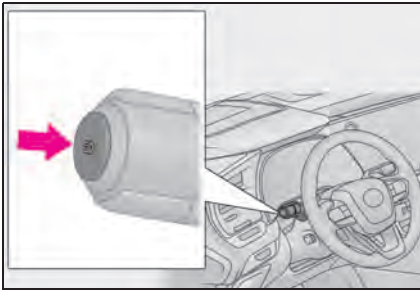

Press the Adaptive High-beam System switch.

The AHS indicator will turn off.

Press the switch to enable the Adaptive High-beam System again.

### ■ Temporarily changing to the low beams

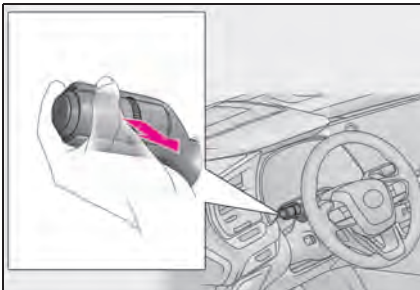

Pull the lever rearward and then return it to its original position.

The high beams will illuminate while the lever is pulled, however, after the lever is returned to its original position, the low beams will remain on for a certain amount of time. After this, the Adaptive High-beam System will operate.

## AHB (Automatic High Beam)

The Automatic High Beam uses a front camera located on the upper portion of the windshield to detect the brightness of the lights of vehicles ahead, streetlights, etc., and automatically changes the head lights between the high beams and low beams.

### Using the Automatic High Beam system

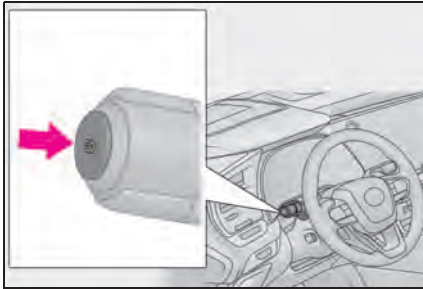

- 1 Press the Automatic High Beam switch.

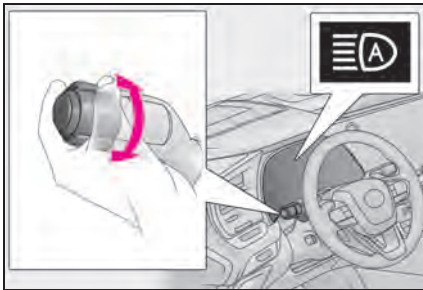

- 2 Turn the headlight switch to the AUTO or  position.

When the headlight switch lever is in the low beam position, the AHB system will be enabled and the AHB indicator will illuminate.

## Turning the high beams on/off manually

### ■ Changing to the high beams

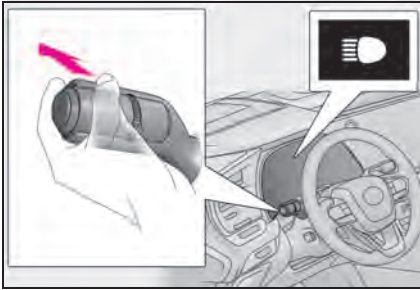

Push the lever forward.

The AHB indicator will turn off and the high beam indicator will turn on.

Pull the lever to its original position to enable the Automatic High Beam system again.

### ■ Changing to the low beams

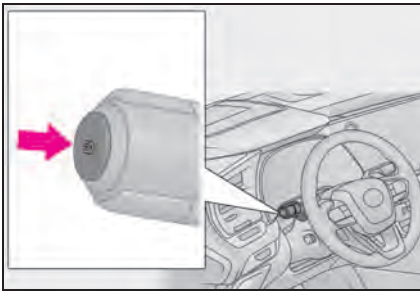

Press the Automatic High Beam switch.

The AHB indicator will turn off.

Press the switch to enable the Automatic High Beam system again.

### ■ Temporarily switching to the low beams

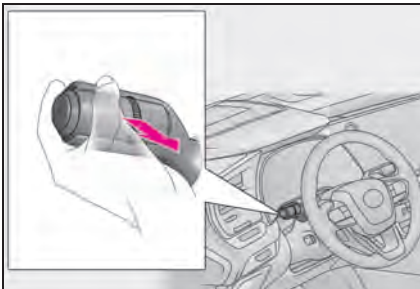

Pull the lever rearward and then return it to its original position.

The high beams will illuminate while the lever is pulled, however, after the lever is returned to its original position, the low beams will remain on for a certain amount of time. After this, the Automatic High Beam system will operate.

## Fog Light Switch

The fog lights secure excellent visibility in difficult driving conditions, such as in rain and fog.

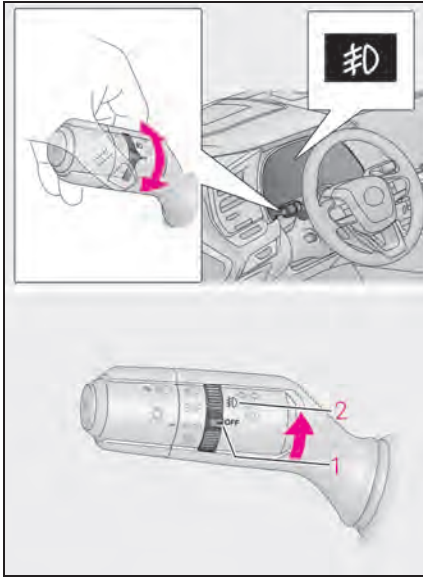

- 1** OFF (U.S.A.) or ⊘ (Canada)  
Turns the fog lights off
- 2** ⊘ Turns the fog lights on



# Windshield Wipers and Washer

When AUTO is selected, the wipers will operate automatically when the sensor detects falling rain. The system automatically adjusts wiper timing in accordance with rain volume and vehicle speed.

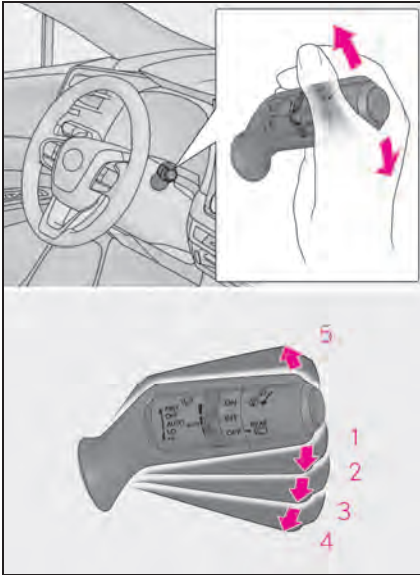

- 1** OFF (U.S.A.) or ○ (Canada) Off
- 2** AUTO Rain-sensing wiper operation
- 3** LO (U.S.A.) or ▼ (Canada)  
Low speed operation
- 4** HI (U.S.A.) or ▼ (Canada)  
High speed operation
- 5** MIST (U.S.A.) or △ (Canada)  
Temporary operation

When is AUTO selected, the sensor sensitivity can be adjusted by turning the switch ring.

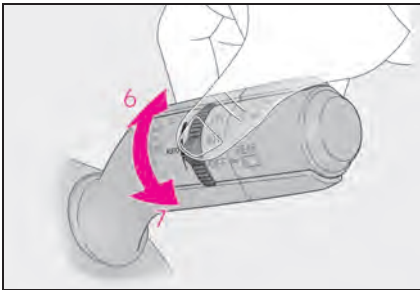

- 6** Increases the sensitivity
- 7** Decreases the sensitivity

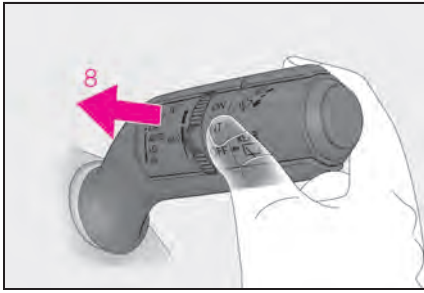

**8**  Washer/wiper dual operation

Pulling the lever operates the wipers and washer.

(After operating several times, the wipers operate once more time after a short delay to prevent dripping. However, the dripping prevention does not operate while the vehicle is moving.)

Vehicles with headlight cleaners:

When the power switch is in ON and the headlights are on, if the lever is pulled, the headlight cleaners will operate once. After this, the headlight cleaners will operate every 5th time the lever is pulled.

## Rear Window Wiper and Washer

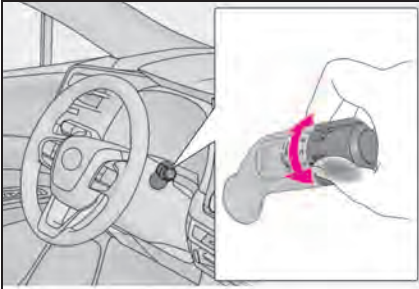

- 1** OFF (U.S.A.) or ○ (Canada) Off
- 2** INT (U.S.A.) or --- (Canada) Intermittent operation
- 3** ON (U.S.A.) or — (Canada) Normal operation

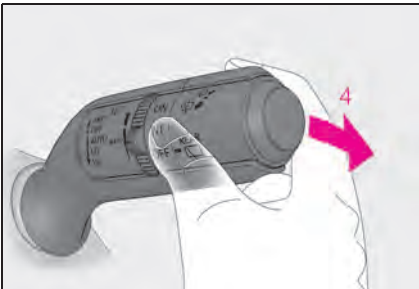
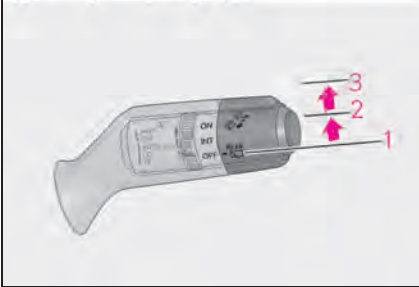

- 4**  Washer/wiper dual operation  
Pushing the lever operates the wiper and washer.

The wiper will automatically operate a couple of times after the washer squirts.

Vehicles with camera cleaning washer:  
The washer will automatically operate and clean the rear camera.\*

\*: Refer to "MULTIMEDIA OWNER'S MANUAL".

# Driving Mode Select Switch

The driving modes can be selected to suit driving conditions.

## Selecting a drive mode

- 1 Select  on the center display.
- 2 Select "Drive mode".
- 3 Select driving mode.

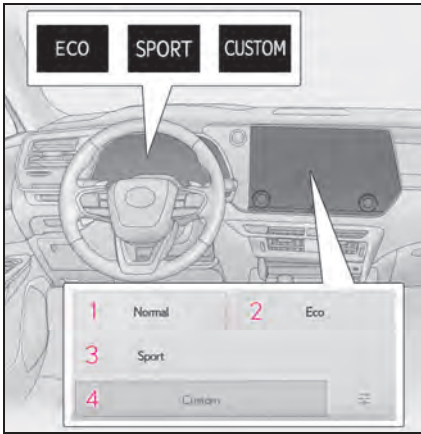

### 1 Normal mode

Provides an optimal balance of fuel economy, quietness, and dynamic performance. Suitable for city driving.

### 2 Eco drive mode

Helps the driver accelerate in an eco-friendly manner and improve fuel economy through moderate throttle characteristics and by controlling the operation of the air conditioning system (heating/cooling).

When the Eco drive mode is selected, Eco drive mode indicator comes on.

### 3 Sport mode

Controls the hybrid system to provide quick, powerful acceleration. This mode also changes the steering feel, making it suitable for when agile driving response is desired, such as when driving on roads with many curves.

When the Sport mode is selected, "Sport" indicator will come on.

### 4 Custom mode

Allows you to drive with the power train, steering and air conditioning system functions set to your preferred settings.

When the Custom mode is selected, Custom mode indicator comes on.

# Basic Operation of Multimedia System

## Map scrolling operation

The map can be moved and a touched point can be set as the center of the map screen.

### ■ Flick/drag operation



The map screen can be moved by touching, dragging or flicking it.

Touch [Recenter] to return to the center of the map to the current position.

### ■ Touch and hold operation

If a desired point on the map screen is touched and held, the full route map screen to the selected point will be displayed.



1 Touch and hold the desired point.

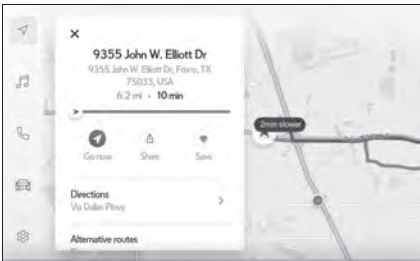

2 Full route map screen will be displayed for the selected point.

# Navigation

The navigation system indicates your present position and assists in locating a desired destination.

## Destination search screen

### ■ Searching for a destination using the keyboard

A destination can be searched for by entering keywords.

**1** Touch [  ] or [  ] on the map screen.

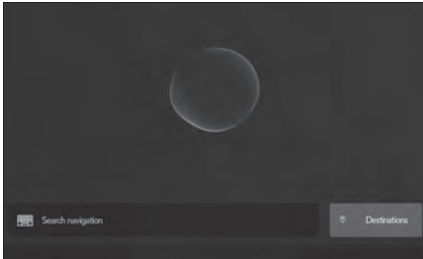

**2** Touch [Search navigation].



**3** Enter characters using the keyboard.

**4** Touch [Go].

**5** Touch the desired item from the list.

## ■ Searching for a destination by category

A destination can be searched for from a list of categories.

1 Touch [🎤] or [🔍] on the map screen.

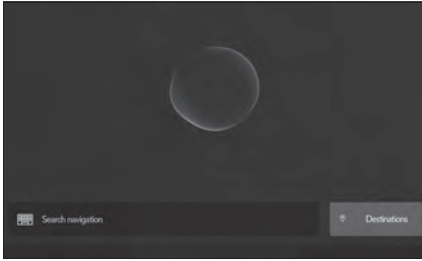

2 Touch [Destinations].

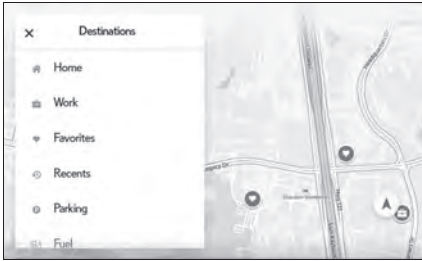

3 Touch [Navigation].

4 Touch the desired search method.

[Home]: Touch to set the registered home as the destination. A point must be registered as home before using this function.\*

[Work]: Touch to set the registered workplace as the destination. A point must be registered as a workplace before using this function.\*

[Favorites]: Touch to set a registered favorite as the destination. A point must be registered as a favorite before using this function.

[Recents]: Touch to set a destination from the destination history as the destination.

[Sent to car]: Send to car enables customer to send a destination or POI to the vehicle from Lexus app.

[Parking]: Touch to search for a nearby parking lot to set as a destination.

[Fuel/Charging]: Touch to search for a fuel station/charging facility to set as a destination.

[Food]: Touch to search for a restaurant to set as a destination.

[Hospitals]: Touch to search for a hospital to set as a destination.

When setting a business as a destination, if your estimated time of arrival is outside of business hours or near closing time, a notification asking to confirm the destination will be displayed.

\*: Home and Work must be added via Lexus app.

5 Touch the desired destination from the list.

### ► Editing the favorites list

The favorites list can be edited.

- 1 Touch [📍] or [🔍] on the map screen.
- 2 Touch [Destinations].
- 3 Touch [Favorites].

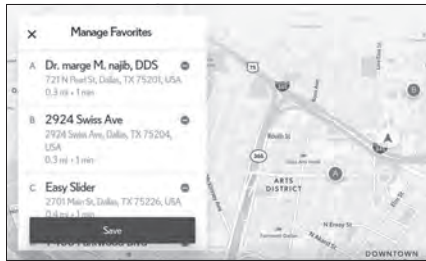

4 Touch [✎].

Touch [⊖] to delete a favorite.

The favorites list editing screen will be displayed.

5 Touch [Save].

### ► Editing the destination history

The destination history can be edited.

- 1 Touch [📍] or [🔍] on the map screen.
- 2 Touch [Destinations].
- 3 Touch [Recents].

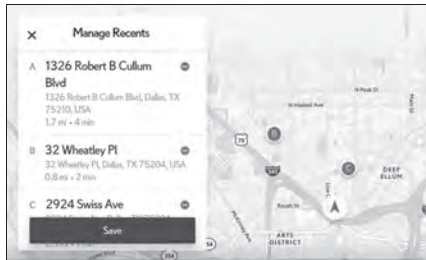

4 Touch [✎].

The destination history editing screen will be displayed.

Touch [⊖] to delete a destination history item.

5 Touch [Save].



## ■ Searching for a destination using voice controls

1 Touch [  ] or [  ] on the map screen.

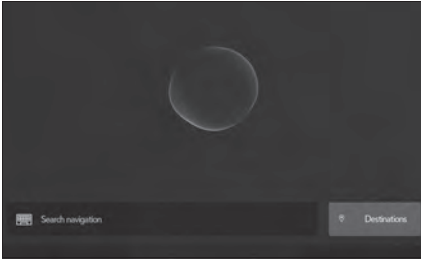

2 Say the keyword you wish to use for the search.

3 Touch or use voice command for desired result from list.

# Connecting a Smartphone or Communication Device

## Registering a Bluetooth® device from the multimedia system

A cellular phone or portable device must be registered in order to use hands-free calling or Bluetooth® audio. Once registration is complete, Bluetooth® will automatically be connected each time the multimedia system is started.

When Apple CarPlay/Android Auto is connected via USB, the device will be registered automatically.

If no Bluetooth® device is connected, the registration screen can also be displayed by pressing and holding the [  ] switch on the steering.

- 1 Touch [  ] from the main menu.
- 2 Touch [Bluetooth & Devices] on the submenu.

If no device is registered, proceed to Procedure 4.

- 3 Touch [Add another device].

While a device is connected to the multimedia system, the confirmation screen for disconnecting the device may be displayed. Disconnect the device to perform registration.

- 4 Touch [Search for devices].

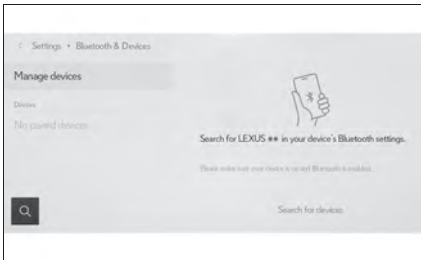

- 5 Touch the device to register from the main area.
  - The Bluetooth® address may be displayed instead of the device name.
  - Certain models of Bluetooth® devices may not be displayed in the device list, unless a certain screen is displayed on the Bluetooth® device. Refer to the Bluetooth® device's instruction manual for details.

- 6 Check that the displayed PIN code matches the PIN code displayed on the Bluetooth<sup>®</sup> device, and then touch [OK].
  - Some Bluetooth<sup>®</sup> devices may need to be operated to complete registration.
  - When an HFP supported Bluetooth<sup>®</sup> device is registered, that device is automatically set as the primary device if the driver does not have a primary device set.
  - The Apple CarPlay or Android Auto settings may be displayed. The Apple CarPlay or Android Auto screen will be displayed if the use of either is enabled.
  - A message indicating that connection is complete is displayed, and the name of the registered Bluetooth<sup>®</sup> device is displayed in the submenu.
  - If an operation failed screen is displayed, follow the operation instructions on the screen.

### ■ Registering from a Bluetooth<sup>®</sup> device

If the Bluetooth<sup>®</sup> device cannot be found by searching with the multimedia system, register by searching for the multimedia system from the Bluetooth<sup>®</sup> device.

- 1 Touch [  ] from the main menu.
- 2 Touch [Bluetooth & Devices] on the submenu.  
If no device is registered, proceed to Procedure 4.
- 3 Touch [Add another device].

While a device is connected to the multimedia system, the confirmation screen for disconnecting the device may be displayed. Disconnect the device to perform registration.

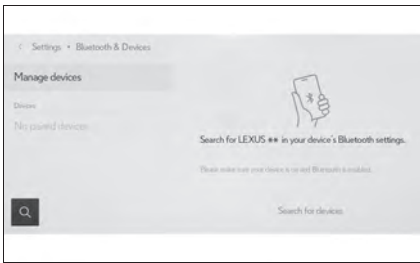

- 4 Register the multimedia system from the Bluetooth<sup>®</sup> device to be used.
  - Perform the operation according to the operating procedure of the Bluetooth<sup>®</sup> device.
  - Be sure to display this Bluetooth<sup>®</sup> connection screen before performing registration on the Bluetooth<sup>®</sup> device.

- 5 Check that the displayed PIN code matches the PIN code displayed on the Bluetooth® device, and then touch [OK].
  - Some Bluetooth® devices may need to be operated to complete registration.
  - When an HFP supported Bluetooth® device is registered, that device is automatically set as the primary device if the driver does not have a primary device set.
  - The Apple CarPlay or Android Auto settings may be displayed. The Apple CarPlay or Android Auto screen will be displayed if the use of either is enabled.
  - A message indicating that connection is complete is displayed, and the name of the registered Bluetooth® device is displayed in the submenu.
  - If an operation failed screen is displayed, follow the operation instructions on the screen.

### ■ Operating with the steering switches (Type A)

Some hands-free call functions can be operated from the steering switches, such as receiving or making calls. The steering switch functions change depending on the status of the multimedia system.

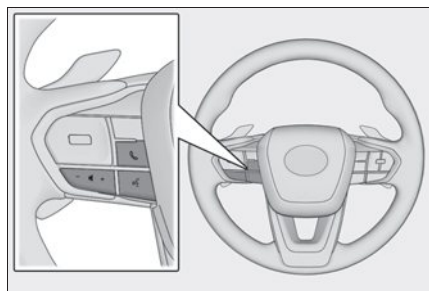

- Operate the switches as necessary.
  - [+] switch
    - Increases the ringtone volume or receiver volume.
    - Press and hold to adjust continuously.
  - [-] switch
    - Decreases the ringtone volume or receiver volume.
    - Press and hold to adjust continuously.

[] switch

Calls can be made using Intelligent Assistant.

To end Intelligent Assistant, press and hold the talk switch.

[] switch

- While a call cannot be made, displays call history screen or phone menu.
- Phone calls can be made when [] is displayed on the phone screen.
- While making a call or during a call, ends the call.
- While receiving a call or during call waiting, answers the call.

## ■ Operating with the steering switches (Type B)

Some hands-free call functions can be operated from the steering switches, such as receiving or making calls. The steering switch functions change depending on the status of the multimedia system.

The steering switches are an electrostatic type. A switch functions when the switch is touched. The displayed switch functions and their position will vary depending on the state of the vehicle and multimedia system.

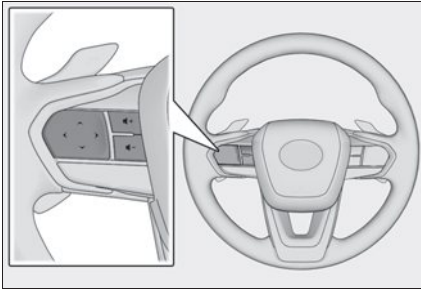

● Operate the switches as necessary.

[  + ] switch

Increases the ringtone volume or receiver volume.

Press and hold to adjust continuously.

[  - ] switch

Decreases the ringtone volume or receiver volume.

Press and hold to adjust continuously.

[  ] switch

Calls can be made using Intelligent Assistant.

To end Intelligent Assistant, press and hold the talk switch.

[  ] switch

- While a call cannot be made, displays call history screen or phone menu.
- Phone calls can be made when [  ] is displayed on the phone screen.
- Change calls/put a call on hold during a call.
- While receiving a call or during call waiting, answers the call.

[  ] switch

- While making a call or during a call, ends the call.
- Decline an incoming call/call waiting call.

## Making calls from call history

Calls can be made to phone numbers that have been recorded in the call history as outgoing or incoming calls.

- 1 Touch [  ] from the main menu.
- 2 Touch [Recents] on the submenu.



- 3 Select the contact.  
For phone numbers that are not registered in the contact, the phone number will be displayed as it is.
- 4 Touch the desired phone number.

## Making calls from the favorites list

Make a call from your favorites list.

- 1 Touch [  ] from the main menu.
- 2 Touch [Favorites] on the submenu.

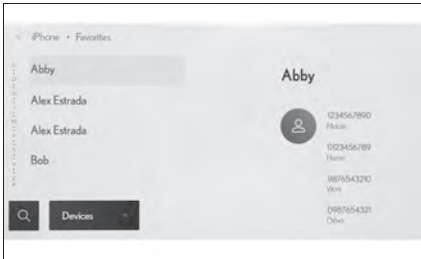

- 3 Select the person you want to call from your favorites list.
- 4 Touch the desired phone number.

## Making calls from contacts

Make a call from the contacts registered on the multimedia system.

- 1 Touch [📞] from the main menu.
- 2 Touch [Contacts] on the submenu.
- 3 Select a contact.

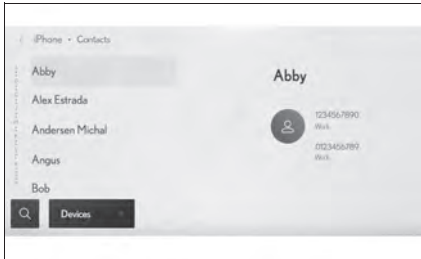

- 4 Touch the desired phone number.

## Answering calls

When there is an incoming call, the incoming call sounds and the incoming call screen or incoming call notification is displayed.

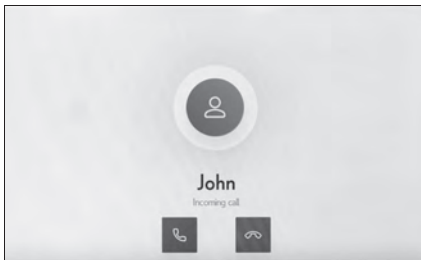

- Answer the call by doing one of the following.
  - Touch [📞].
  - Press the [📞] switch on the steering.

## Making calls from the message function

Hands-free calls can be made using the message function.

- Touch the blue number to make a call.
- Consecutive numbers may be recognized as phone numbers. In addition, some phone numbers, such as phone numbers from other countries, may not be recognized.

# Basic Operation of Audio System

## Changing the audio source

Source can be changed to radio, USB, etc.

- 1 Touch [  ] from the main menu.
- 2 Touch [Sources].
- 3 Touch the source you wish to select.

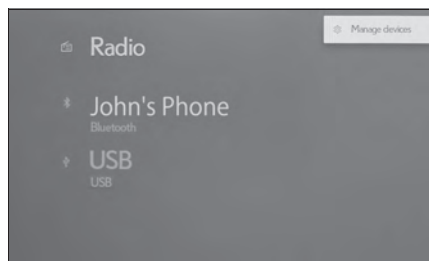

## Listening to the radio

Switch to your preferred frequency or service and listen to the radio.

- 1 Touch [  ] from the main menu.
- 2 Touch [Sources].
- 3 Touch [Radio].
- 4 Select the station selection method or service as necessary.
  - [Favorites]: Select a broadcasting station from those registered as favorites.
  - [Tune]: Select the broadcasting station by entering a frequency with the numeric keypad.
  - [FM Radio]: Switches to FM mode. The FM station list, the 3 most recently listened stations, and the receivable FM broadcasting stations are displayed.
  - [AM Radio]: Switches to AM mode. The AM station list, the 3 most recently listened stations, and the receivable AM broadcasting stations are displayed.
  - [SiriusXM]: Switches to SiriusXM Radio mode. Displays [For You] and contents/Super Categories/[All channels]/[Listening History]. (This function is not available in some countries or areas)
- 5 Select the broadcasting station from the station list or genre.





- 6 Operate the radio that is being received as necessary.
- Operating AM/FM from the screen



[Ch]: Touch [ - ] or [ + ] to search for the receivable broadcasting stations. Touch and hold to jump to the next frequency with available radio signal. When released, the broadcasting station closest to that position with the best reception sensitivity is selected automatically.

[Scan]: SEEK UP and output the audio of the detected station for 10 sec. This is repeated.

[  ]: Displayed when Multicast CH is supported in FM mode. Touch to display the SPS channel list. The mode can be changed to the displayed SPS channel list.

[  ]: Registers the currently received broadcasting station in favorites. When registered, touch to cancel.

Preset buttons of submenu: Receive the registered broadcasting stations.

- Operating SiriusXM Radio from the screen  
(This function is not made available in some countries or areas)

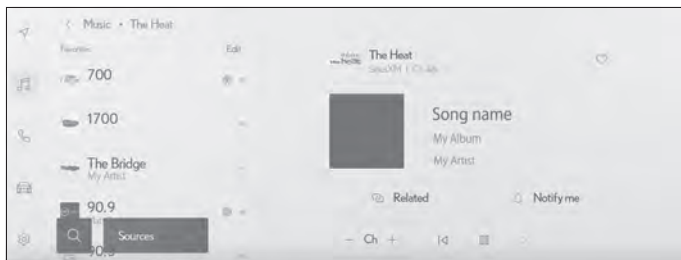

[Ch]: Touch [ - ] or [ + ] to search for the receivable channels. Touch and hold to jump to the next frequency with available radio signal. When released, the current channel is received.

[ < ]/[ > ]: Fast rewind or fast forward the radio cache. Touch and hold to jump to the start or end of the buffer.

[ || ]: Pause the radio cache.

[ ▶ ]: Play the radio cache.

[Related]: Displays related channels on the Related Channels drawer menu.

[Notify me]: Select an artist or song, or both an artist and song, to receive a notification when the corresponding broadcast starts. (When receiving a regular channel) Select a sports team to receive a notification when the corresponding broadcast starts. (When receiving a sport channel)

[ ♥ ]: Registers the currently received channel in favorites. When registered, touch to cancel.

Preset buttons of sub menu: Receive the registered channels.

- Operating with the steering switches

### ► Type A

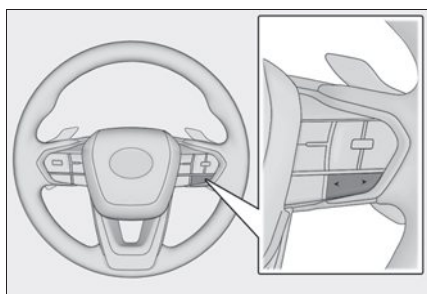

[ < ]/[ > ] switches

- AM/FM Radio

Switch the frequencies or broadcasting stations registered in the preset buttons in order.

Press and hold to switch frequencies. When released, the broadcasting station closest to that position with the best reception sensitivity is selected automatically.

- SiriusXM Radio

Switch the channels registered in the preset buttons in order.

Press and hold to switch channels. When released, the channel closest to that position with the best reception sensitivity is selected automatically.

## ► Type B

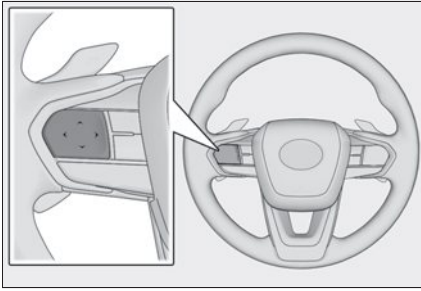

[<]/[>]switches

This switch can be used if set as a favorite steering switch through customization.

For the customization procedure, refer to the "OWNER'S MANUAL".

- AM/FM Radio

Switch the frequencies or broadcasting stations registered in the preset buttons in order.

Press and hold to switch frequencies. When released, the broadcasting station closest to that position with the best reception sensitivity is selected automatically.

- SiriusXM Radio

Switch the channels registered in the preset buttons in order.

Press and hold to switch channels. When released, the channel closest to that position with the best reception sensitivity is selected automatically.

## Playing iPod/iPhone

Play back music files on an iPod/iPhone connected to the USB port. When an iPod/iPhone is connected, a button with the device's name is displayed on the source selection screen. This may not be displayed for some devices.

Connect an iPod or iPhone.

- 1 Touch [  ] from the main menu.
  - 2 Touch [Sources].
  - 3 Touch the device name or [USB].
  - 4 Operate the iPod or iPhone that is playing as necessary.
- Perform operations from the screen

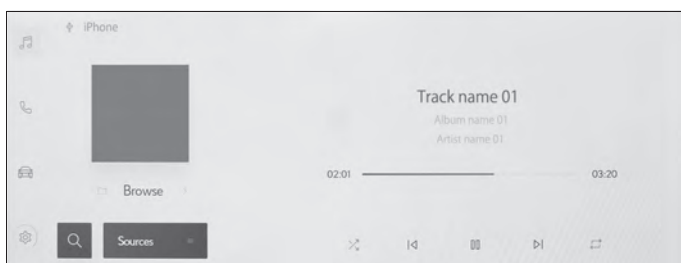

[  ]: Performs shuffle playback. Each touch switches the shuffle setting.\*

[  ]: Plays the currently playing track from the beginning. When at the start of the track, the previous track will play from the beginning.

Touch and hold to fast rewind. Release to start playback from that position.

[  ]: Pauses playback.

[  ]: Plays.

[  ]: Switches the tracks. Touch and hold to fast forward. Release to start playback from that position.

[↺]: Performs repeat playback. Each touch switches the repeat setting.\*

[Browse]: Displays the playback mode in the submenu. Tracks can be selected from a list sorted by artist, album, song, playlist, genre, Podcast, composer, audiobook, or radio. [Shuffle play] is displayed when playing a track selected from the list. Touch this to return to the playback screen and perform shuffle playback.

\*: The order in which shuffle or repeat settings switch depends on the connected device.

● Operating with the steering switches

► **Type A**

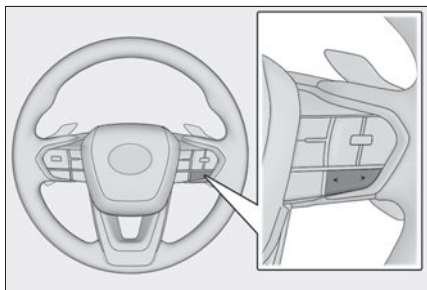

[<]/[>]switches

Switch the tracks.

Press and hold to fast rewind or fast forward. Release to start playback from that position.

► **Type B**

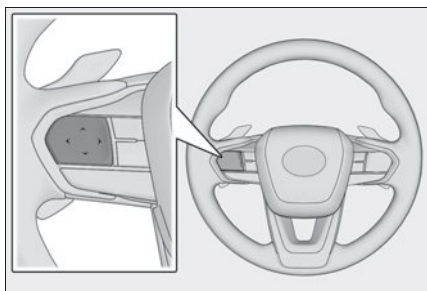

[<]/[>]switches

This switch can be used if set as a favorite steering switch through customization.

For the customization procedure, refer to the "OWNER'S MANUAL".

Switch the tracks.

Press and hold to fast rewind or fast forward. Release to start playback from that position.

## Lexus Climate Concierge

The climate control seats are automatically controlled according to the set temperature of the air conditioning system, outside temperature, cabin temperature, etc. Lexus Climate Concierge allows a comfortable condition to be maintained without adjusting each system.

### Turning on Lexus Climate Concierge

Lexus Climate Concierge operates in conjunction with "AUTO" of the air conditioning system.

- 1** Select the option screen switch.
- 2** Select the "Climate concierge" switch.
- 3** Turn the "AUTO" switch on.

# Front Automatic Air Conditioning System

When the “AUTO” switch is on, the air outlets and fan speed will automatically be changed according to the set temperature.

## Air conditioning controls

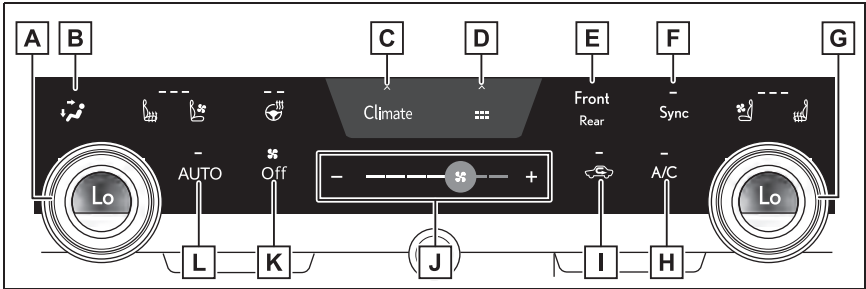

- A** Left-hand side temperature control switch
- B** Airflow mode control switch
- C** Option screen switch
- D** Shortcut screen switch  
Select to display shortcut icons for various functions.
- E** Front/rear control screen switch
- F** “Sync” switch
- G** Right-hand side temperature control switch
- H** “A/C” switch
- I** Outside/recirculated air mode switch
- J** Fan speed control switch
- K** “Off” switch
- L** “AUTO” switch

## Rear Air Conditioning System

The rear air conditioning system can be operated selecting “Rear” switch on the center display and rear air conditioning system control panel.

### Rear air conditioning control operation

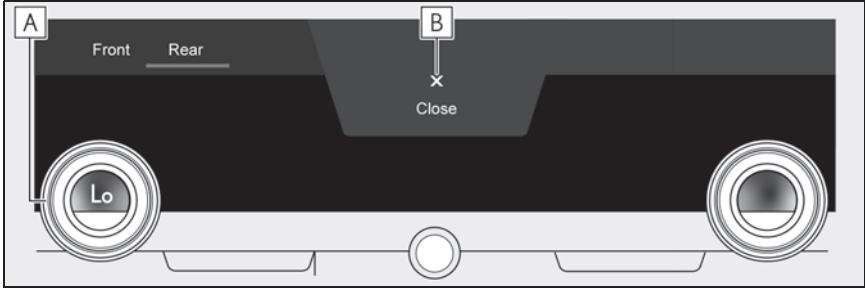

- A** Rear seats temperature control switch

Turn temperature control dial clockwise to increase the temperature and turn the dial counterclockwise to decrease the temperature.

- B** Close the rear air conditioning control screen



## Starting Voice Control

Voice control can be started by any of the following operations:

### ■ Press the talk switch

Press the [  ] switch (talk switch) on the steering.

#### ▶ Type A

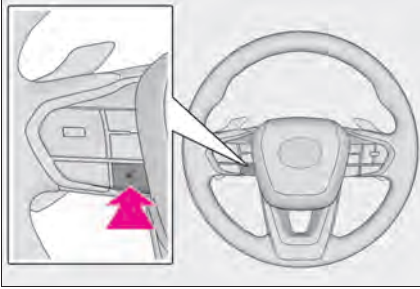

#### ▶ Type B

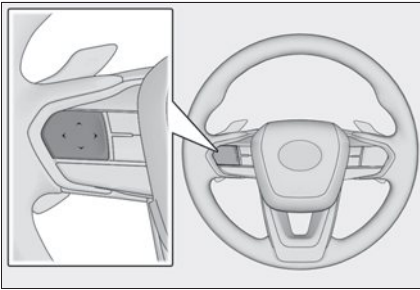

The position of each switch function will vary depending on the state of the vehicle and multimedia system.

### ■ Say the wake word

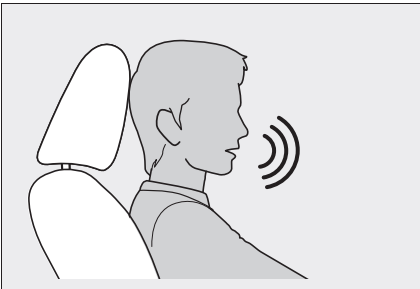

Say "Hey Lexus"

- The wake word can be turned on or off.
- The wake word can be used and then immediately issue a voice command.

Example: "Hey Lexus, take me to an Italian restaurant."

## ■ Touch the voice search button



Touch [  ] or [  ] on the screen.

## Function list

The following tables list frequently used commands for each function category.

- The functions available may vary according to the system installed.
- Items with “Subscription” will require Intelligent Assistant functionality.

### ■ Common

Action	Example voice command	Subscription
Shows list of general commands	“Help”	No
Stops the current conversation and re-starts at the beginning	“Start over”	No
Cancels the Intelligent Assistant system	“Cancel”	No

### ■ Navigation

Intelligent Assistant system enables navigation voice search. This allows you with variety of features such as searching a point of interest (POI), navigate to an address as well as discovering new POIs.

Function	Example voice command	Subscription
Destination search	“Take me to <location category/business name>” “Take me to an Italian restaurant” “Take me to <address>” “Take me to 6565 Headquarters drive Plano TX” “Take me home” “Take me to work”	Yes
Map control	“Map zoom in” “Map zoom out”	Yes
Route information	“Cancel trip”	Yes
Telematics	“Call destination assist”	No

## ■ Multimedia control

Allows you to engage in a dialog with the Intelligent Assistant to complete various multimedia tasks via voice input.

Function	Example voice command	Subscription
Radio	"Tune to 99.5 FM" "Tune to Rock on FM" "Tune to channel 2 on SiriusXM"	No
Media	"Mute audio" "Next" "Previous"	No
Media Streaming	"Play <artist/album/song/genre/playlist>" "Play Frank Sinatra"	Yes

## ■ Hands-free phone operation

Allows you to engage in a dialog with the Intelligent Assistant to complete various tasks via voice input, such as making a phone call to a contact, or calling destination assist.

Function	Example voice command	Subscription
Phone call	"Call John Smith" "Dial 0123456789" "Call back" "Redial"	No
Message	"Send message to John Smith" "Read message"	No

## ■ Screen display switching

Allows you to easily change to various function screen by voice.

Function	Example voice command	Subscription
Navigation	"Show map"	Yes
Phone	"Show recent calls"	No
Multimedia	"Show the FM station list"	No
Settings	"Show display settings"	No

## ■ Vehicle device control

Allows you to easily change a vehicle setting or activate a function by voice.

Function	Example voice command	Subscription
Climate	"Turn on the air conditioner" "Set the temperature to 70 degrees" "Turn the fan speed up"	No

## ■ Notifications

Offers notifications based on user preferences, vehicle geolocation and learned behavior. Each service can be set to On/Off from the Lexus app.

Function	Detail	Subscription
POI suggestion (Navigation)	Parking suggestions near destination	Yes
Low fuel reminder (Navigation)	Automatically notifies user of low fuel level. If applicable, provides POI list nearby (ahead) or along route and allows user to select and navigate by touch.	Yes

## Connecting a device via the USB port

Connect a device such as smartphone or portable player.

- Connect the USB cable to the port.

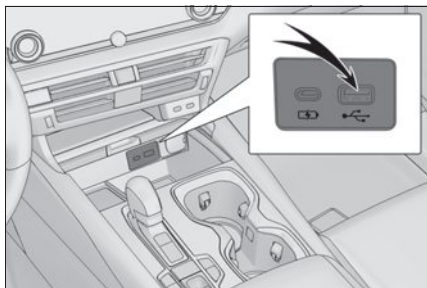

When connecting a USB flash drive, connect it directly to the USB port.

## Safety Connect

Safety Connect is a subscription-based telematics service that uses Global Positioning System (GPS) data and embedded cellular technology to provide safety and security features to subscribers. Safety Connect is supported by Lexus' designated response center, which operates 24 hours per day, 7 days per week.

Safety Connect service is available by subscription on select, telematics hardware-equipped vehicles.

By using the Safety Connect service, you are agreeing to be bound by the Telematics Subscription Service Agreement and its Terms and Conditions, as in effect and amended from time to time, a current copy of which is available at Lexus.com. All use of the Safety Connect service is subject to such then-applicable Terms and Conditions.

## System components

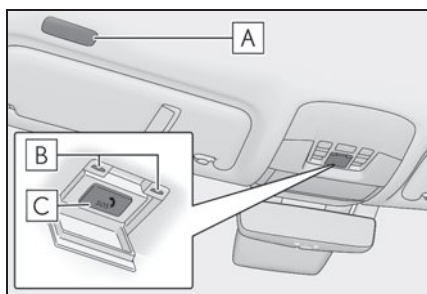

- A** Microphone
- B** LED light indicators
- C** "SOS" button

## Services

Subscribers have the following Safety Connect services available:

- Automatic Collision Notification\*  
Helps drivers receive necessary response from emergency service providers.  
\*: U.S. Patent No. 7,508,298 B2
- Stolen Vehicle Location  
Helps drivers in the event of vehicle theft.
- Emergency Assistance Button ("SOS")  
Connects drivers to response-center support.
- Enhanced Roadside Assistance  
Provides drivers various on-road assistance.

## Subscription

After you have signed the Telematics Subscription Service Agreement and are enrolled, you can begin receiving services.

A variety of subscription terms is available for purchase. Contact your Lexus dealer, call the following or push the “SOS” button in your vehicle for further subscription details.

- The United States

1-800-25-LEXUS (1-800-255-3987)

- Canada

1-800-26-LEXUS (1-800-265-3987)

- Puerto Rico

1-877-539-8777

## Remote Connect

Remote Connect is a smartphone application that lets you view and remotely control certain aspects of your vehicle. For details about the functions and services of this application, refer to <http://www.lexus.com/enform/>. Function of the Remote Connect is achieved by using an embedded cellular device in the vehicle (DCM: Data Communication Module).

## Subscription

After you sign the Telematics Subscription Service Agreement, download the Lexus App from your smartphone's app store, and register within the app (or enroll and complete registration at the dealer), you can begin using these services.

A variety of subscription terms are available. Contact your Lexus dealer, or call 1-800-25-LEXUS (1-800-255-3987) for further subscription details.



## Service Connect

Service Connect uses embedded telematics hardware to collect and transmit vehicle data that allows Lexus to provide:

- Vehicle Health Report (VHR) (Safety Recalls, Service Campaigns, Current Vehicle Alerts, Required Maintenance, and Vehicle Condition Status)
- Maintenance Notifications
- Vehicle Alert Notifications

For details about this service and how to register, refer to <http://www.lexus.com/enform/>. The Service Connect is achieved by using a Data Communication Module (DCM) built in the vehicle.

## Side Doors

The vehicle can be locked and unlocked using the entry function, wireless remote control or door lock switches.

### Unlocking and locking the doors from the inside

#### Door lock switches (to lock/unlock)

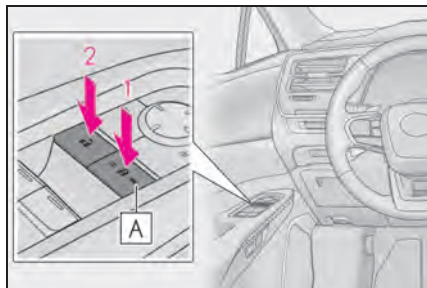

- 1** Driver's door: Locks all the doors  
Doors other than the driver's door: Locks the doors  
The indicator **A** comes on.
- 2** Driver's door: Unlocks all the doors  
Doors other than the driver's door: Unlocks the doors  
The indicator **A** turns off.

### Opening the doors from outside the vehicle

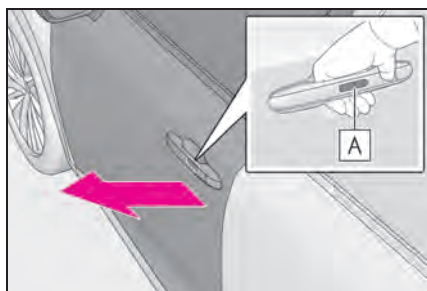

Press the door opener switch **A** of the door handle to open the door.

Make sure to securely press the door opener switch **A** on the inner side of the door handle

### Opening the doors from inside the vehicle

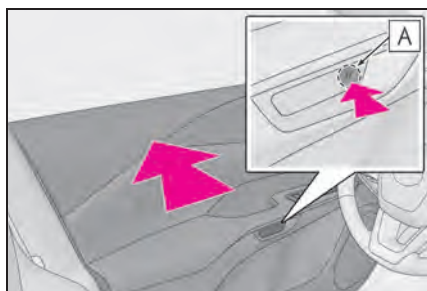

Press the front side of the door opener switch **A** to open the door.

Driver's door: The door will open even if it is locked.

When the door is unlocked, the door lock indicator will turn off.

## Rear door child-protector lock

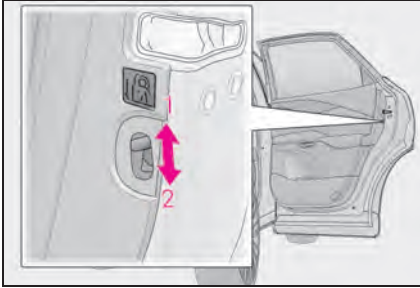

The door cannot be opened from inside the vehicle when the lock is set.

- 1 Unlock
- 2 Lock

These locks can be set to prevent children from opening the rear doors. Push down on each rear door switch to lock both rear doors.

# Power Windows

## Opening and closing the power windows

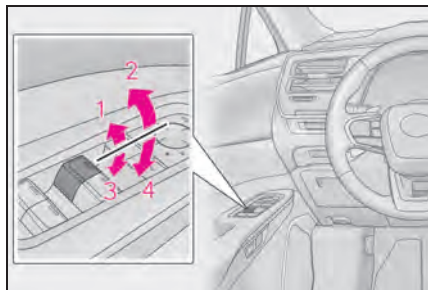

- 1 Closing
- 2 One-touch closing\*
- 3 Opening
- 4 One-touch opening\*

\*: To stop the window partway, operate the switch in the opposite direction.

## Preventing accidental operation (window lock switch)

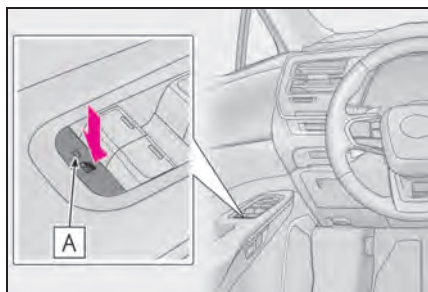

Press the switch.

The indicator **A** will come on and the passenger windows will be locked.

The passenger windows can still be opened and closed using the driver's switch even if the lock switch is on.

# Moon Roof (if equipped)

## Operating the moon roof

### Opening and closing

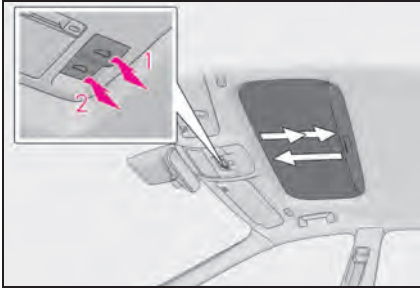

**1** Opens the moon roof\*

The moon roof stops slightly before the fully open position to reduce wind noise.

Press the switch again to fully open the moon roof.

**2** Closes the moon roof\*

\*: Lightly press either side of the moon roof switch to stop the moon roof partway.

### Tilting up and down

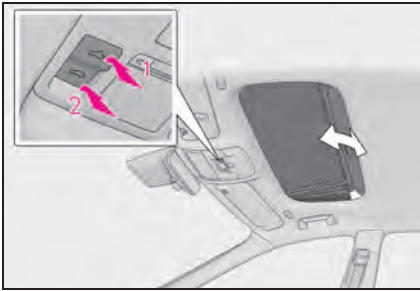

**1** Tilts the moon roof up\*

**2** Tilts the moon roof down\*

\*: Lightly press either side of the moon roof switch to stop the moon roof partway.

## Panoramic Moon Roof (if equipped)

### Operating the panoramic moon roof

#### ■ Opening and closing the electronic sunshade

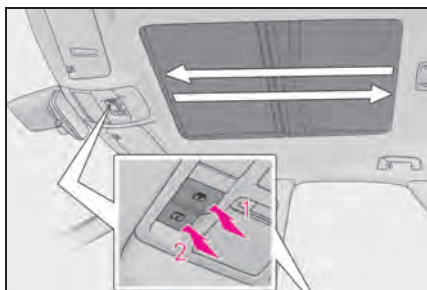



#### 1 Opens the electronic sunshade

If the  switch is pressed and held, the electronic sunshade will fully open automatically.\*<sup>1</sup>

#### 2 Closes the electronic sunshade

If the  switch is pressed and held, the electronic sunshade will fully close automatically.\*<sup>2</sup>

\*<sup>1</sup>: Lightly press either end of the  switch to stop the electronic sunshade while it is operating.

\*<sup>2</sup>: Lightly press either end of the  switch to stop the electronic sunshade while it is operating.

#### ■ Tilting the panoramic moon roof up and down

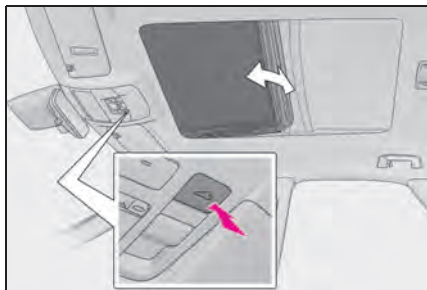

Tilts the panoramic moon roof up (press)\*

When the panoramic moon roof is tilted up, the electronic sunshade will open to the half-open position of the roof.

\*: Lightly press the  switch again to stop the panoramic moon roof partway.

Tilts the panoramic moon roof down (press and hold)

The panoramic moon roof can be tilted down only when it is in the tilt-up position.

## ■ Opening and closing the panoramic moon roof

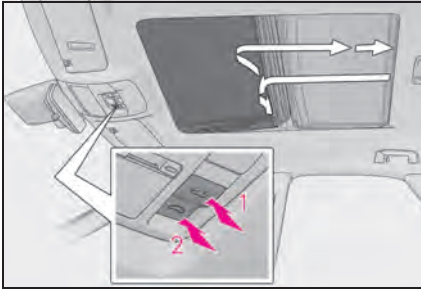

### 1 Opens the panoramic moon roof\*1

Lightly press either end of the panoramic moon roof  switch to stop the panoramic moon roof while it is operating.

The panoramic moon roof can be opened from the tilt-up position.

### 2 Closes the panoramic moon roof\*2

The panoramic moon roof can be opened from the tilt-up position.

Press the  switch. The panoramic moon roof will fully close automatically.

\*1: Lightly press either end of the  switch to stop the electronic sunshade while it is operating.

\*2: Lightly press either end of the  switch to stop the electronic sunshade while it is operating.

# How to Charge

## When charging

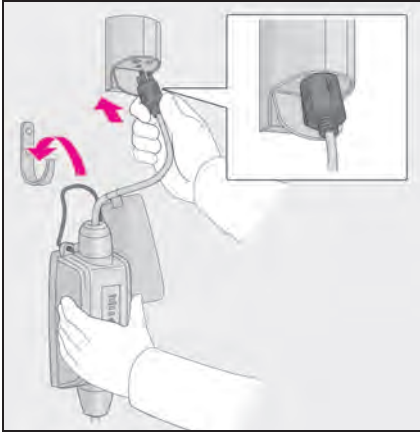

- 1 Prepare the AC charging cable.

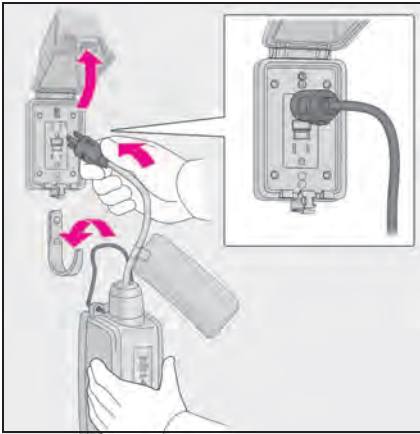

- 2 Insert the AC charging cable into the socket of the external power source.

Make sure to hold the body of the plug and insert it firmly into the socket. Check that the power indicator on the CCID (Charging Circuit Interrupting Device) is illuminated. Use a string, etc. to hang the CCID (Charging Circuit Interrupting Device) on a hook or equivalent when a load is applied to the socket and plug due to the installation height of the socket.

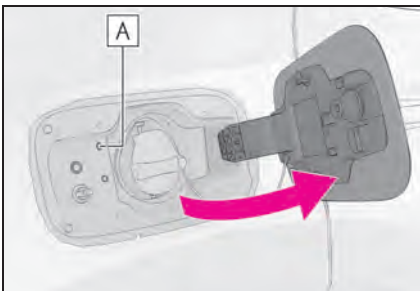

- 3 Unlock the doors and open the charging port lid.

The AC charging inlet light (A) will illuminate.



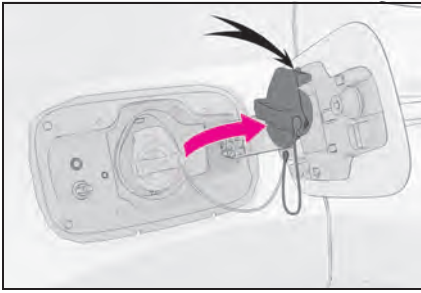

- 4** Remove the AC charging inlet cap and secure it into the holder on the charging port lid.

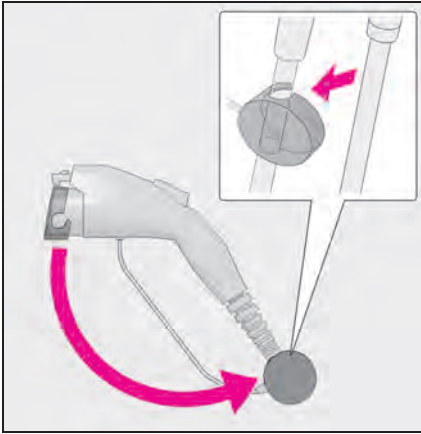

- 5** Remove the AC charging connector cap and secure it to the cable.

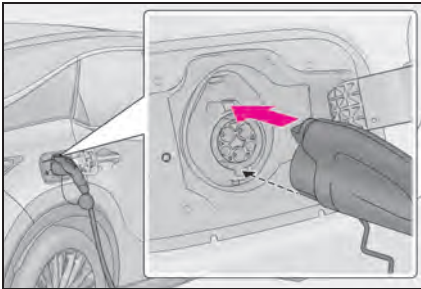

- 6** Insert the charging connector into the AC charging inlet.

Align the guide position on the bottom of the charging connector, and push the charging connector straight into the AC charging inlet as far as possible.

Once a click sound is heard, check that the charging connector is securely locked.

When the charging connector is inserted straight as far as possible, it will automatically lock.

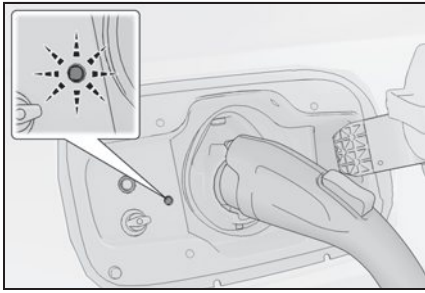

- 7 Confirm that the charging indicator of the charging port is illuminated.

Charging will not start if the charging indicator does not illuminate when the charging connector is inserted.

If the charging indicator is flashing, the charging schedule is registered.

The charging indicator will turn off when charging is completed.

The charging indicator will also turn off when charging is interrupted.

# Power Back Door

## Opening/closing the power back door

### ■ From the inside

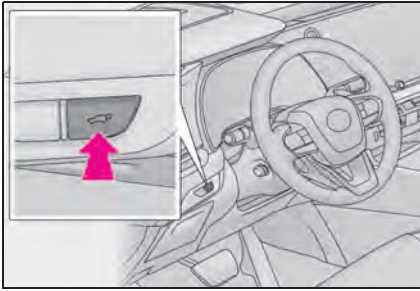

Press and hold the switch for approximately 1 second.

A buzzer will sound and the power back door will automatically open or close. However, if the power back door is locked, it will not open.

Pressing the switch while the power back door is opening/closing will stop the operation.

Pressing and holding the switch again for approximately 1 second will operate the power back door in the opposite direction.

### ■ From the outside

#### ▶ Smart access system with push-button start

→P.18

#### ▶ Wireless remote control

→P.16

#### ▶ Back door opener switch

● Open

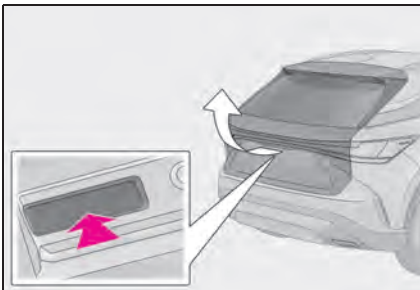

When the power back door is unlocked: Press the back door opener switch.

When the power back door is locked: While carrying an electronic key, press and hold the back door opener switch.

A buzzer will sound and the power back door will automatically open.

Pressing the switch while the power back door is opening/closing will stop the operation.

● Close

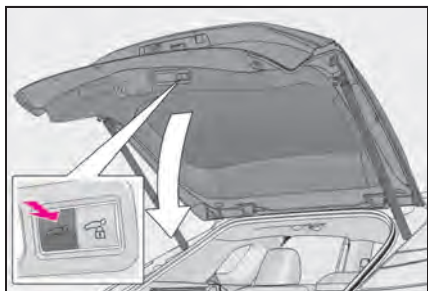



Press the  switch.

A buzzer will sound and the power back door will automatically close.

Pressing the  switch while the power back door is closing will stop the operation. Pressing the switch again will open the power back door automatically.

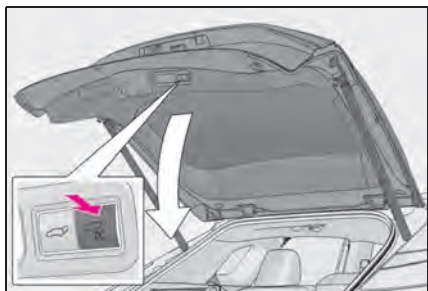
- Close the back door and lock all doors after moving away from the back door (close & lock [Walk-Away] function)



- 1** Close all of the doors except the back door, carrying an electronic key and press the  switch on the lower part of the back door.

A different buzzer than the normal one will sound and the close & lock (Walk-Away) function will go into standby.

- 2** While the buzzer is sounding, move away from the back door.

When the sensor detects that you are away from the back door, the emergency flashers will flash, and the buzzer will sound. Depending on the direction of moving away from the back door, the location and how to hold the electronic key or circumstances, it may not be detected properly.

All the doors other than the back door will be locked, and after the back door is closed, the back door will also be locked. When all the doors have been closed and locked, the buzzer (if equipped) will sound and the emergency flashers will flash.

The standby state is canceled if you do not move away from the back door for 30 seconds. To operate the function again, perform the procedure again from the beginning.

If you approach the back door carrying the electronic key, the back door operation will stop, all the doors will be unlocked, and the buzzer (if equipped) will sound and the emergency flashers will flash.

If the  switch is pressed after the back door operation has stopped, the close & lock (Walk-Away) function will go into standby again.

- Close the back door and lock all doors (close & lock function)\*

\*: This setting can be customized by your Lexus dealer.

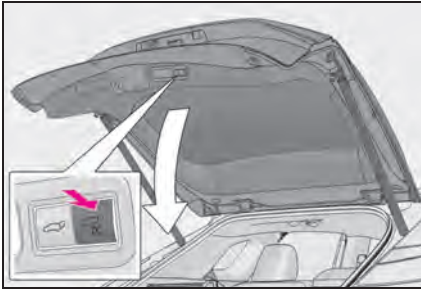

Press the  switch.

The power back door will close and all of the doors will be locked at the same time.

A different buzzer than the normal one will sound and the power back door will begin closing automatically. When the power back door is closed, all of the doors will lock simultaneously and operation signals will indicate that all of the doors have been locked.

If the  switch is pressed while the power back door is closing, the operation will stop.

Pressing the switch again will open the power back door automatically.

### ■ Hands Free Power Back Door (if equipped)

- 1 While carrying an electronic key, stand within the smart access system with push-button start operation range, approximately 19.7 to 23.6 in. (50 to 60 cm) from the rear bumper.

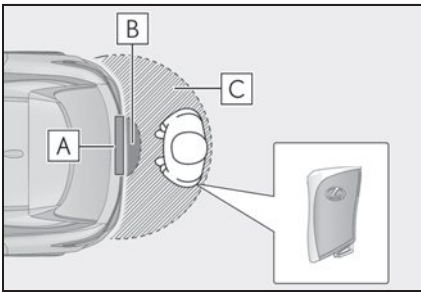

- A** Kick sensor
- B** Hands Free Power Back Door operation detection area
- C** Smart access system with push-button start operation detection area

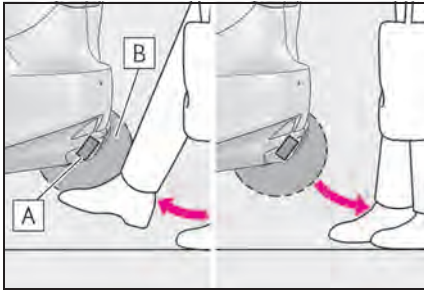

**2** Perform a kick operation by moving your foot to within approximately 3.9 in. (10 cm) of the rear bumper and then pulling your foot back after the buzzer sounds.

- Perform the entire kick operation within 1 second.
- The Hands Free Power Back Door will not start operating while a foot is detected under the rear bumper.
- Operate the Hands Free Power Back Door without contacting the rear bumper with your foot.
- If another electronic key is in the cabin or luggage compartment, it may take slightly longer than normal for the operation to occur.
- If the buzzer sounds twice, perform a kick operation again.

**A** Kick sensor

**B** Hands Free Power Back Door operation detection area

**3** When the kick sensor detects that your foot is pulled back, a buzzer will sound and the power back door will automatically fully open/close.

If kick operation is performed again in the middle of back door operating, the operation will stop.

## ■ Closing and locking the back door after moving away from the back door using the kick sensor (Hands Free close & lock [Walk-Away] function)<sup>\*1,2</sup>

\*1: If equipped

\*2: This setting can be customized by your Lexus dealer.

- 1 While carrying an electronic key, stand within the smart access system with push-button start operation range, approximately 19.7 to 23.6 in. (50 to 60 cm) from the rear bumper.

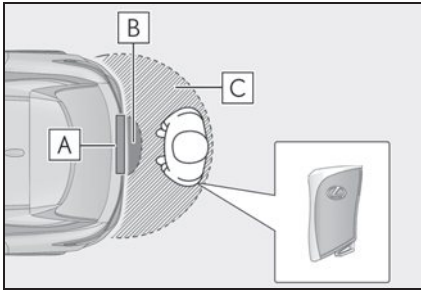

- A** Kick sensor
- B** Hands Free Power Back Door operation detection area
- C** Smart access system with push-button start operation detection area

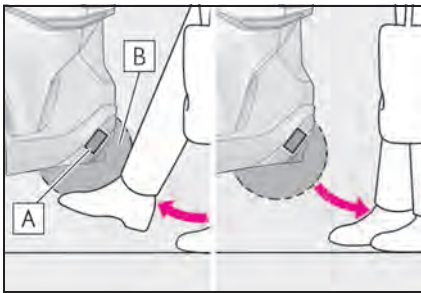

- 2 Perform a kick operation by moving your foot to within approximately 3.9 in. (10 cm) of the rear bumper and then pulling your foot back after the buzzer sounds.

- Perform the entire kick operation within 1 second.
- The Hands Free Power Back Door will not start operating while a foot is detected under the rear bumper.
- Operate the Hands Free Power Back Door without contacting the rear bumper with your foot.
- If another electronic key is in the cabin or luggage compartment, it may take slightly longer than normal for the operation to occur.
- If the buzzer sounds twice, perform a kick operation again.

- A** Kick sensor
- B** Hands Free Power Back Door operation detection area

- 3 When the kick sensor detects that your foot is pulled back, a different buzzer than the normal one will sound and the Hands Free close & lock (Walk-Away) function will go into standby.
- 4 While the buzzer is sounding, move away from the back door.

When the sensor detects that you are away from the back door, the emergency flashers will flash, and the buzzer will sound. Depending on the direction of moving away from the back door, the location and how to hold the electronic key or circumstances, it may not be detected properly.

All the doors other than the back door will be locked, and after the back door is closed, the back door will also be locked. When all the doors have been closed and locked, the buzzer (if equipped) will sound and the emergency flashers will flash.

The standby state is canceled if you do not move away from the back door for 30 seconds. To operate the function again, perform the procedure again from the beginning.

If you approach the back door carrying the electronic key, the back door operation will stop, all the doors will be unlocked, and the buzzer (if equipped) will sound and the emergency flashers will flash.

If the power back door is operated after the back door operation has stopped, the Hands Free close & lock (Walk-Away) function will go into standby again.



# Fuel Tank Cap

## Before refueling the vehicle

- Close all the doors and windows, and turn the power switch off.
- Confirm the type of fuel.

## Opening the fuel tank cap

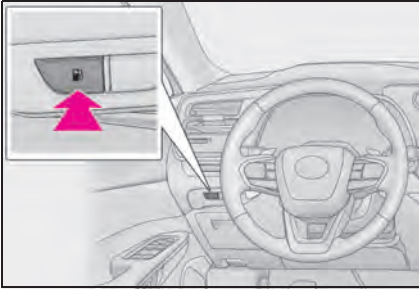

- 1 Press the switch to open the fuel filler door.

The fuel filler door will open within about 10 seconds of the switch being pressed. Before refueling is possible, a message will be shown on the multi-information display in the instrument cluster to indicate the progress of the fuel filler door opener.

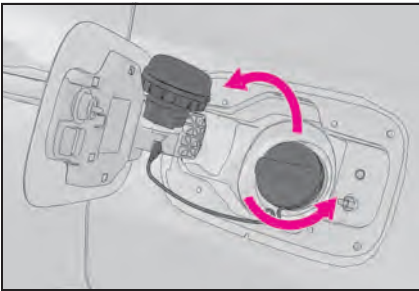

- 2 Turn the fuel tank cap slowly and remove it, then put it into the holder on the fuel filler door.

## Closing the fuel tank cap

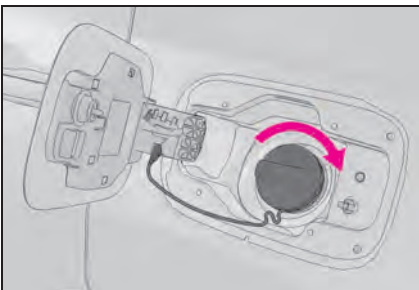

After refueling, turn the fuel tank cap until you hear a click. Once the cap is released, it will turn slightly in the opposite direction.

## Garage Door Opener

The garage door opener can be programmed using the HomeLink<sup>®</sup> to operate garage doors, gates, entry doors, door locks, home lighting systems, security systems, and other devices.

### ■ HomeLink<sup>®</sup> programming procedure

The programming procedures can also be found at the following URL.

Website: [www.homelink.com/lexus](http://www.homelink.com/lexus)



For support, contact customer support at the following.

Help Line: 1-800-355-3515

## System components

The HomeLink<sup>®</sup> wireless control system in your vehicle has 3 buttons which can be programmed to operate 3 different devices. Refer to the programming methods on the following pages to determine the method which is appropriate for the device.

### ► Vehicles with auto anti-glare inside rear view mirror

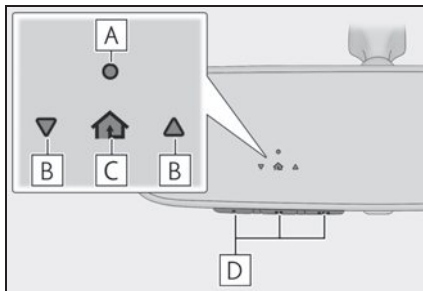

- A** HomeLink<sup>®</sup> indicator light
- B** Garage door operation indicators
- C** HomeLink<sup>®</sup> icon

Illuminates while HomeLink<sup>®</sup> is operating.

- D** Buttons

## ► Vehicles with Digital Rearview Mirror

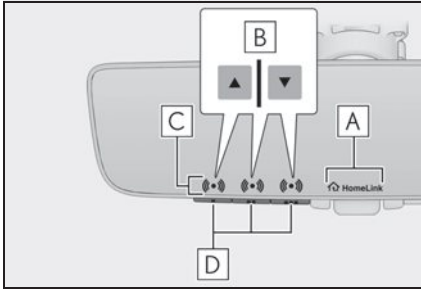

### **A** HomeLink® logo

Appears while HomeLink® is operating. When the menu button is pressed, the logo disappears even while the HomeLink® is operating.

### **B** Garage door operation indicators

### **C** HomeLink® indicator light

Illuminates above each button selected.

### **D** Buttons

## Programming the HomeLink®

### ■ Before programming HomeLink®

- During programming, it is possible that garage doors, gates, or other devices may operate. For this reason, make sure that people and objects are clear of the garage door or other devices to prevent injury or other potential harm.
- It is recommended that a new battery be placed in the remote control transmitter for more accurate programming.
- Garage door opener motors manufactured after 1995 may be equipped with rolling code protection. If this is the case, you may need a stepladder or other sturdy, safe device to reach the “Learn” or “Smart” button on the garage door opener motor.

## ■ Programming HomeLink®

Steps 1 through 3 must be performed within 60 seconds, otherwise the HomeLink® indicator light will stop flashing and programming will not be successfully completed.

- 1 Press and release the HomeLink® button you want to program and check that the HomeLink® indicator light flashes (orange).
- 2 Point the remote control transmitter for the device at the rear view mirror, 1 to 3 in. (25 to 75 mm) from the HomeLink® buttons.

Keep the HomeLink® indicator light in view while programming.

### ▶ Vehicles with auto anti-glare inside rear view mirror

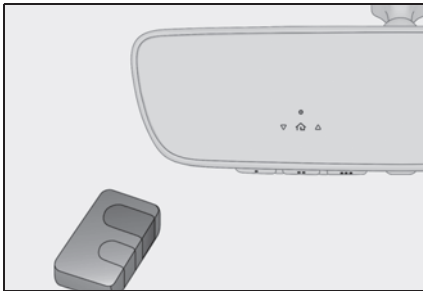

### ▶ Vehicles with Digital Rearview Mirror

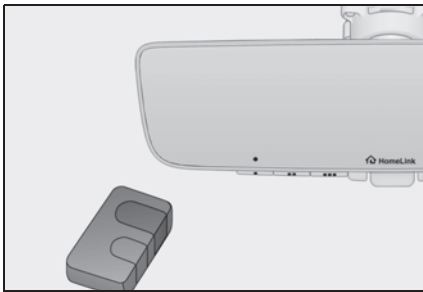

- 3 Program a device.

### ▶ Vehicles with auto anti-glare inside rear view mirror



## ► Vehicles with Digital Rearview Mirror

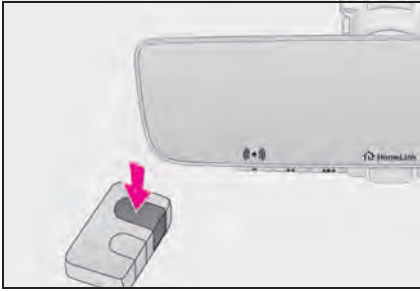

### ► Programming a device other than an entry gate (for U.S.A. owners)

Press and hold the remote control transmitter button until the HomeLink<sup>®</sup> indicator light changes from slowly flashing orange to rapidly flashing green (rolling code) or continuously lit green (fixed code), then release the button.

### ► Programming an entry gate (for U.S.A. owners)/Programming a device in the Canadian market

Press and release the remote control transmitter button at 2 second intervals, repeatedly, until the HomeLink<sup>®</sup> indicator light changes from slowly flashing (orange) to rapidly flashing (green) (rolling code) or continuously lit (green) (fixed code).

- 4 Test the HomeLink<sup>®</sup> operation by pressing the newly programmed button and observing the indicator light:
  - HomeLink<sup>®</sup> indicator light illuminates: Programming of a fixed code device has completed. The garage door or other device should operate when a HomeLink<sup>®</sup> button is pressed and released.
  - HomeLink<sup>®</sup> indicator light flashes rapidly: The garage door opener motor or other device is equipped with a rolling code. To complete programming, firmly press and hold the HomeLink<sup>®</sup> button for 2 seconds then release it.
  - If the garage door or other device does not operate, proceed to "Programming a rolling code system".
- 5 Repeat the steps above to program another device for any of the remaining HomeLink<sup>®</sup> buttons.

## ■ Programming a rolling code system

Two or more people may be necessary to complete rolling code programming.

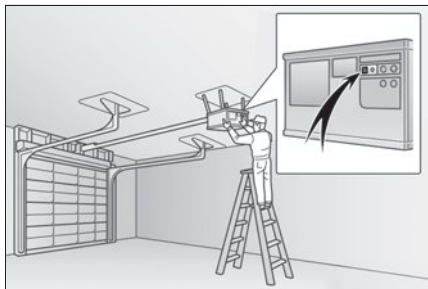

- 1 Locate the “Learn” or “Smart” button on the garage door opener motor in the garage.

This button can usually be found where the hanging antenna wire is attached to the unit. The name and color of the button may vary by manufacturer. Refer to the owner’s manual supplied with the garage door opener motor for details.

- 2 Press and release the “Learn” or “Smart” button.

Perform **3** within 30 seconds after performing **2**.

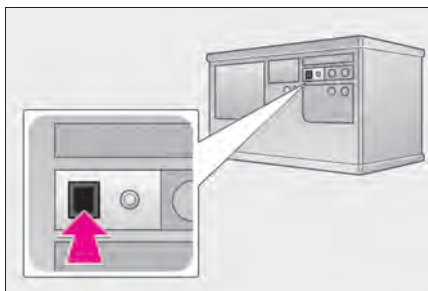

- 3 Press and hold the desired HomeLink<sup>®</sup> button (inside the vehicle) for 2 seconds and release it. Repeat this sequence (press/hold/release) up to 3 times to complete programming.

If the garage door opener motor operates when the HomeLink<sup>®</sup> button is pressed, the garage door opener motor recognizes the HomeLink<sup>®</sup> signal.

### ► Vehicles with auto anti-glare inside rear view mirror



## ► Vehicles with Digital Rearview Mirror



### ■ Enabling 2-way communication with a garage door (only available for compatible devices)

When enabled, 2-way communication allows you to check the status of the opening and closing of a garage door through indicators in your vehicle.

2-way communication is only available if the garage door opener motor used is a compatible device. (To check device compatibility, refer to [www.homelink.com](http://www.homelink.com).)

- 1 Within 5 seconds after programming the garage door opener has been completed, if the garage door opener motor is trained to HomeLink<sup>®</sup>, both garage door operation indicators will flash rapidly (green) and the light on the garage door opener motor will blink twice, indicating that 2-way communication is enabled.

If the indicators do not flash, perform **2** and **3** within the first 10 presses of the HomeLink<sup>®</sup> button after programming has been completed.

- 2 Press a programmed HomeLink<sup>®</sup> button to operate a garage door.
- 3 Within 1 minute of pressing the HomeLink<sup>®</sup> button, after the garage door operation has stopped, press the “Learn” or “Smart” button on the garage door opener motor. Within 5 seconds of the establishment of 2-way communication with the garage door opener, both garage door operation indicators in the vehicle will flash rapidly (green) and the light on the garage door opener motor will blink twice, indicating that 2-way communication is enabled.

### ■ Reprogramming a single HomeLink<sup>®</sup> button

When the following procedure is performed, buttons which already have devices registered to them can be overwritten:

- 1 Press and hold the desired HomeLink<sup>®</sup> button.
- 2 When the HomeLink<sup>®</sup> indicator starts flashing orange, release the HomeLink<sup>®</sup> button and perform “Programming HomeLink<sup>®</sup>” **1** (it takes 20 seconds for the HomeLink<sup>®</sup> indicator to start flashing).

## Operating HomeLink®

Press the appropriate HomeLink® button. The HomeLink® indicator light should turn on. The status of the opening and closing of a garage door is shown by the indicators.

### ► Vehicles with auto anti-glare inside rear view mirror

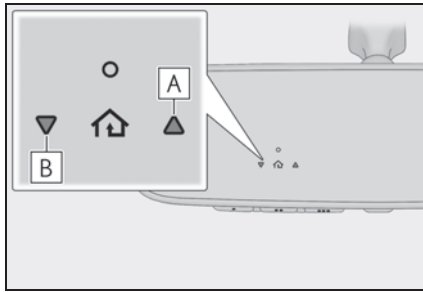

**A** Opening

**B** Closing

### ► Vehicles with Digital Rearview Mirror

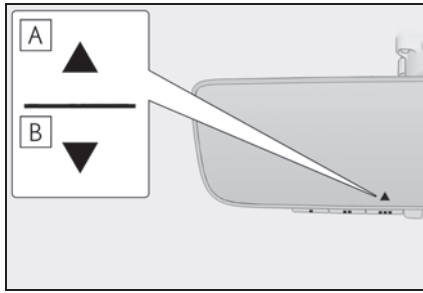









**A** Opening

**B** Closing

This function is only available if the garage door opener motor used is a compatible device. (To check device compatibility, refer to [www.homelink.com](http://www.homelink.com).)

Color	Status
Orange (flashing)	Currently opening/closing
Green	Opening/closing has completed
Red (flashing)	Feedback signals cannot be received

The indicators can operate within approximately 820 ft. (250 m) of the garage door. However, if there are obstructions between the garage door and the vehicle, such as houses and trees, feedback signals from the garage door may not be received.

To recall the previous door operation status, press and release either HomeLink® buttons  and  or  and  (vehicles with auto anti-glare inside rear view mirror),  and  or  and  (vehicles with Digital Rearview Mirror), simultaneously. The last recorded status will be displayed for 3 seconds.



## What to do if...

### List of Warning/Indicator Lights

Immediately stop the vehicle in a safe place and contact your Lexus dealer. Continuing to drive the vehicle may be dangerous.

**BRAKE**

(U.S.A.)

Brake system warning light



(red)

(Canada)

Immediately stop the vehicle in a safe place and contact your Lexus dealer.



Charging system warning light



(U.S.A.)

Malfunction indicator lamp



Low engine oil pressure warning light



(Canada)

Have the vehicle inspected by your Lexus dealer immediately.



(yellow)

Brake system warning light



Intuitive parking assist OFF indicator (if equipped)



SRS warning light



(illuminates)

Slip indicator

**ABS**

(U.S.A.)

ABS warning light

**PARK**

(flashes)

(U.S.A.)

Parking brake indicator



(Canada)



(flashes)

(Canada)



(Red or

yellow)

Electric power steering system warning light



(flashes)

Brake hold operated indicator



(Blinking and then continuously on)

Tire pressure warning light

For further information, refer to the "OWNER'S MANUAL".

## What to do if...

### Follow the correction procedures.



Inappropriate pedal operation warning light



Low fuel level warning light



Driver's and front passenger's seat belt reminder light



Rear passengers' seat belt reminder light



(Illuminates without blinking)

Tire pressure warning light\*



Intuitive parking assist OFF indicator (if equipped)



PCS warning light



LTA indicator



(orange)

LDA indicator



(orange)

Dynamic radar cruise control indicator



(orange)

Cruise control indicator



(orange)

PDA indicator



Driving assist information indicator



(flashes)  
(U.S.A.)

Parking brake indicator



(flashes)  
(Canada)

### Stop and check.



High coolant temperature warning light



Hybrid system overheat warning light

For further information, refer to the "OWNER'S MANUAL".

## What to do if...

### See the "OWNER'S MANUAL"



Turn signal indicator



(U.S.A.)

Headlight indicator



(Canada)

Tail light indicator



Headlight high beam indicator



AHS indicator (if equipped)  
AHB indicator



Fog light indicator



PCS warning light



(green/white)

Cruise control indicator



(green/white)

Dynamic radar cruise control indicator



(green/white)

LDA indicator



LDA OFF indicator  
(if equipped)



(green/white)

LTA indicator



Outside rear view mirror indicators



Intuitive parking assist  
OFF indicator  
(if equipped)



Driving assist information indicator



(flashes)

Slip indicator



VSC OFF indicator



"READY" indicator



(U.S.A.)

Parking brake indicator



(Canada)



Brake hold standby indicator



Brake hold operated indicator



EV indicator



Low outside temperature indicator



(green/white)

PDA indicator



Stop light indicator

For further information, refer to the "OWNER'S MANUAL".

## What to do if...

### See the "OWNER'S MANUAL"



REC indicator

#### ● Drive mode indicators



AUTO EV/HV mode indicator

ECO

Eco drive mode indicator



EV drive mode indicator

SPORT

Sport mode indicator



HV drive mode indicator

CUSTOM

Customize mode indicator



Hybrid battery charge mode indicator



Trail Mode indicator

For further information, refer to the "OWNER'S MANUAL".

- \*: It also comes on due to natural causes such as natural air leaks and tire inflation pressure changes caused by temperature. Adjust the tire inflation pressure to the specified level. The light will turn off after a few minutes. In case the light does not turn off even if the tire inflation pressure is adjusted, have the system checked by your Lexus dealer.

## What to do if...

### If the electronic key does not operate properly

#### Locking and unlocking the doors

Use the mechanical key in order to perform the following operations:

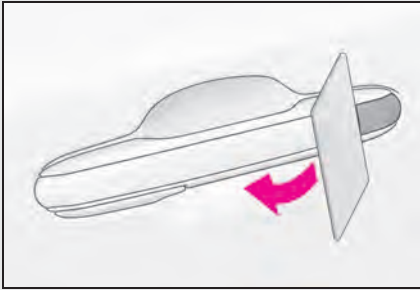

- 1 Insert a plastic card, etc. into the gap in the door handle to pry up the cover.

To avoid damage, do not apply excessive force to the cover.

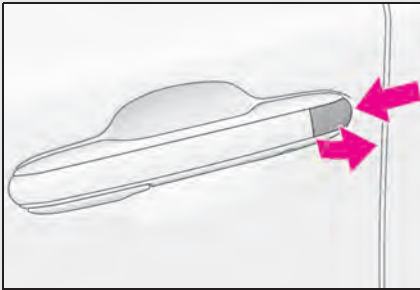

- 2 Remove the cover by pressing it on the rear.

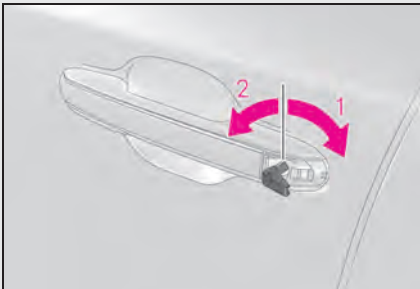

- 3 Use the mechanical key in order to perform the following operations:

- 1 Unlocks all the doors

Turning the key rearward unlocks the driver's door. Turning the key again unlocks the other doors.

- 2 Locks all the doors

## What to do if...

### Starting the hybrid system

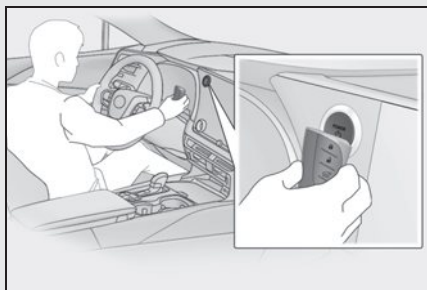

- 1 Ensure that the shift position is in P and depress the brake pedal.
- 2 Touch the Lexus emblem side of the electronic key to the power switch.

When the electronic key is detected, a buzzer will sound and the power switch mode will change to ON.

When the smart access system with push-button start is deactivated in customization setting, the power switch will turn to ACC.

- 3 Firmly depress the brake pedal and check that  is shown on the multi-information display.
- 4 Press the power switch shortly and firmly.

In the event that the hybrid system still cannot be started, contact your Lexus dealer.

If the electronic key battery becomes depleted, a warning message will be shown on the multi-information display. Replace the battery with a new one. For instructions on replacing the battery, refer to the "OWNER'S MANUAL".

If you need further assistance, contact your Lexus dealer.

## What to do if...

### If the hybrid system doesn't start

Make sure that the correct operating procedures have been followed.

**Brake pedal**

Make sure that the brake pedal is firmly depressed when attempting to start the hybrid system. (→P.19)

If the hybrid system still does not start, see the "OWNER'S MANUAL" for more information or contact your Lexus dealer.

## What to do if...

### If a door cannot be opened using the door opener switch

If a door cannot be opened using the door opener switch, it can be opened using a manual release handle.

#### Opening a door using the manual release handle

##### ■ Opening a door using the manual release handle from outside the vehicle

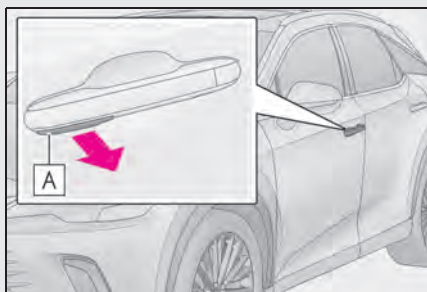

Pull the manual release handle **A** to open the door.

Normally, the manual release handles cannot be used to open the doors.

To open a door, enable manual release handle operation.

##### ■ Opening a door using the manual release handle from inside the vehicle

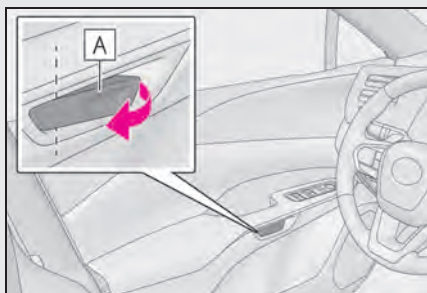

Pull the manual release handle **A** twice to open the door.

Pulling the handle once will enable operation. Pulling the handle again will open the door.



## What to do if...

### ■ Enabling outside manual release handle operation using the mechanical key

Operation of a manual release handle can be enabled by unlocking a door with the mechanical key.

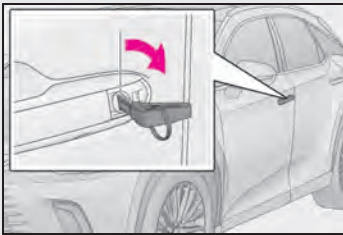
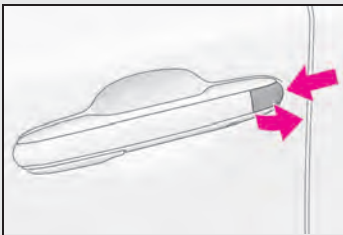
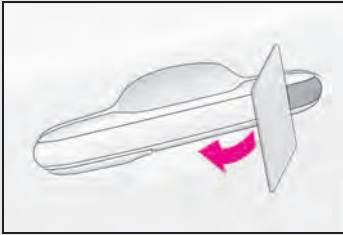

- 1 Insert a plastic card, etc. into the gap in the door handle to pry up the cover.

To avoid damage, do not apply excessive force to the cover.

- 2 Remove the cover by pressing it on the rear.

- 3 Using the mechanical key, turn the lock cylinder to the unlock side to enable the manual release handle operation.

The mechanical key can only be inserted in one direction, as the key only has a groove on one side.

If the key cannot be inserted in a lock cylinder, turn it over and re-attempt to insert it.

**Memo**

A large white rectangular area with horizontal lines, serving as a memo template. The lines are evenly spaced and extend across the width of the page, providing a guide for writing.



### **Your Lexus dealer**

Your Lexus dealer will provide quality maintenance and any other assistance you may require.

If there is not a Lexus dealer near you, please call the following number:

#### **■ U.S. OWNERS**

- In the U.S. mainland or Canada:

Lexus Roadside Assistance

**1-800-25-LEXUS or 1-800-255-3987 (Toll-Free)**

- In Hawaii:

Servco Automotive Roadside Assistance/Customer Services

**1-800-25-LEXUS or 1-800-255-3987 (Toll-Free)**

#### **■ CANADIAN OWNERS**

- In Canada or the U.S. mainland:

Lexus Roadside Assistance/Customer Service

**1-800-26-LEXUS or 1-800-265-3987 (Toll-Free)**

Please access our **websites** for further information.

- The U.S. mainland: **[www.lexus.com](http://www.lexus.com)**

- Hawaii: **[www.servcolexus.com](http://www.servcolexus.com)**

- Canada: **[www.lexus.ca](http://www.lexus.ca)**

©2023 TOYOTA MOTOR CORPORATION

All rights reserved. This material may not be reproduced or copied, in whole or in part, without the written permission of Toyota Motor Corporation.



Owner's Manual Quick Guide:

Publication No. OM48N48U

Part No. 01999-48N48

Printed in Japan 01-2308-00 

RX450h+ Owner's Manual Quick Guide (北米U)